

PRODUCT MODELS

- C-EP Cover
- Evolution Cover
- Legend / LegendX Cover

PURPOSE OF THE REPAIR PROCEDURE

This repair procedure should be performed when wipers need to be replaced on the C-EP, Evolution, Legend, or LegendX swim spa cover.

PREPARATION

- Gather the required tools, as seen in the table at right.
- Make sure the parts kit is complete and that parts have not been damaged during transport. Call your local dealer if parts need to be replaced.

TOOLS REQUIRED

Heat gun	Non-abrasive cleaning pad
Isopropyl alcohol (IPA)	

PARTS KIT

	WHITE	LATTE	PLAT.
I-Beam Wiper support assembly	218960	225927	225926

Version française à la page 3.

⚠ CAUTION

It is recommended to remove/install the wiper(s) when the ambient temperature is between 70 °F to 100 °F.

Before removing/installing the wiper(s), it is strongly recommended to reduce the water vapor steam generated by the spa. To do this; stop the agitation of the water by turning off the recirculation pump, and then set the temperature of the spa water to be between 2 and 5 degrees under the ambient temperature. Wait until the water has reached the ambient temperature or use a plastic canvas to stop the vapor steam.

⚠ WARNING

This procedure must be performed by a certified Covana installer.

Keep the key out of the key switch socket at all times. The certified Covana installer must keep control of the key during the repair procedure. Derogation from this directive could cause serious injury or damage the cover.

STEP BY STEP PROCEDURE

A- REMOVING THE DEFECTIVE WIPER(S)

- 1) Raise the cover halfway to a comfortable working height.
- 2) Pull the defective wiper to remove it. A heat gun can also be used to gently heat the glue.

⚠ CAUTION

Do not use the heat gun too close to the cover surface, as the cover could melt or delaminate.

- 3) Clean the glue residue left on the cover with isopropyl alcohol (IPA) and a non-abrasive cleaning pad. Any residue could interfere with the wiper installation procedure.

B- INSTALLING THE NEW WIPER(S)

⚠ CAUTION

For covers between 12' and 15', there should be 6 wiper brackets, for 16' to 20', there should be 10, and for 21' and 24', there should be 12. Make sure the I-beams are dry and clean.

Make sure ambient temperature is between 70 °F to 100 °F for the wiper installation.

- 1) Peel back the red siding of the double-sided tape of a new wiper (see image 1).

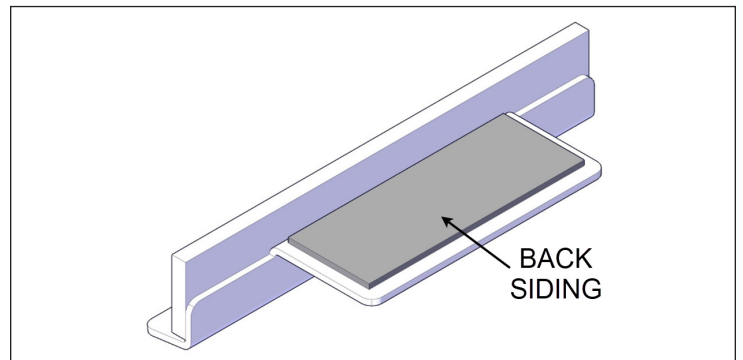

IMAGE 1

- 2) Locate an I-beam under the cover, and orientate the wide flap of the wiper outwards of the cover (see image 2).

⚠ WARNING

Failure to properly install the wipers will impede performance.
Failure to install each wiper bracket properly can result in excessive cover leakage.

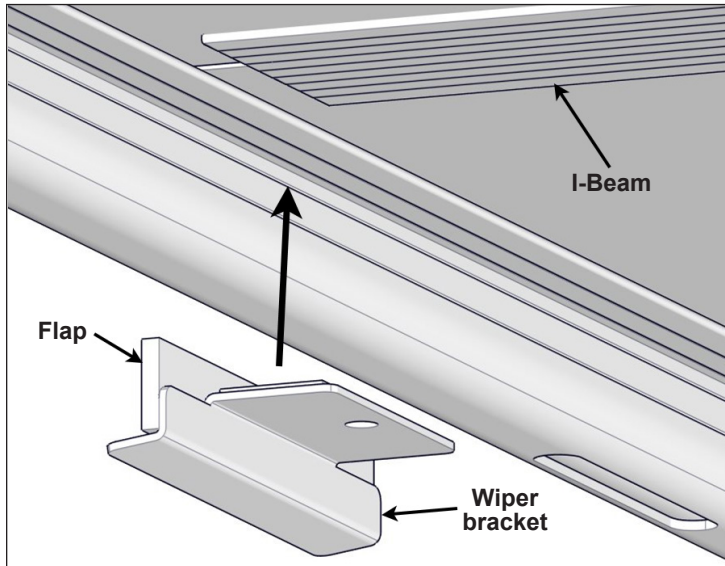

IMAGE 2

NOTE

At the final position of the wiper, the flap must touch the edge of the I-beam (see image 3).

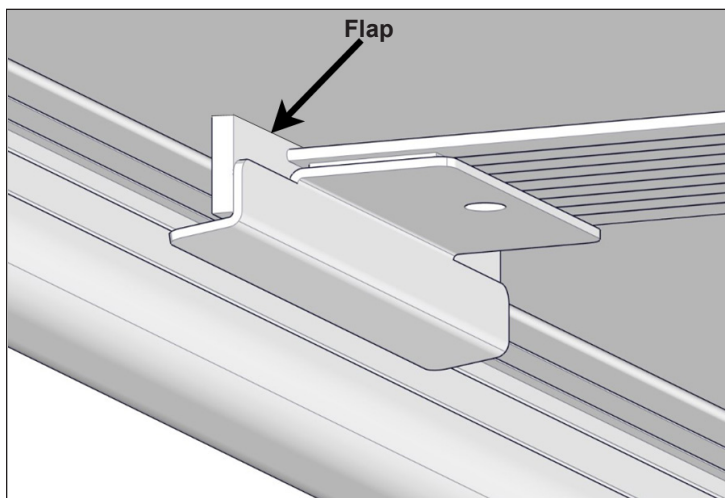

IMAGE 3

- 3) Stick the wiper bracket on the middle of the I-beam by holding it in place and maintaining pressure for at least 60 seconds. This ensures a proper bond to the I-beam. Make sure to install the wiper flap at the edge of the I-beam directly into the gap between the I-beam and the C-channel (see image 3).
- 4) Repeat the previous steps for each defective wiper.

- 5) Put the key back in the key switch socket. Operate the spa cover normally to see if everything is correct. If there is any issue with the cover, please refer to the troubleshooting section of the Owner's manual or call Covana for the Technical Support department.