

COVANA

HORIZON INSTALLATION MANUAL



TABLE OF CONTENTS

TABLE OF CONTENTS	2
SAFETY	4
Safety information.....	4
Avoiding the risk of electrocution.....	5
LABELLING	7
GLOSSARY	10
HARDWARE IDENTIFICATION TABLE	15
INSTALLATION PREPARATION	18
Location considerations.....	18
Foundation preparation.....	19
Installation information.....	20
INSTALLATION	21
Uncrating	21
Cover assembly.....	24
Tub mount assembly	29
Post ground anchoring bracket assembly (optional)	30
Post assembly	33
Lifting mechanism assembly	34
Tub mounting.....	39
Anchoring the Horizon (optional).....	41
Testing the Horizon cover.....	42
Wiper brackets installation.....	43
Seal application	44
ELECTRICAL HOOK-UP	46
Avoiding the risk of electrocution.....	46
Grounding and power supply connection	47
TECHNICAL SPECIFICATIONS	48
Side elevation dimensions.....	48
Frame dimensions and footprint.....	49
Electrical specifications.....	49
Operating limitations.....	50

General specifications	50
Limit switch adjustment.....	51
TROUBLESHOOTING	52
APPENDIX	54
Wiring diagram (North America) – 60 Hz, 120 VAC Operator.....	55
Wiring diagram (Europe) – 50 Hz, 220 VAC Operator	56
INSTALLATION CHECKLIST (Customer copy).....	57
INSTALLATION CHECKLIST (Installer copy).....	59

SAFETY

IMPORTANT SAFETY INSTRUCTIONS

SAVE THESE SAFETY INSTRUCTIONS AND REVIEW THEM REGULARLY.

Safety information

The Covana cover was designed, tested and certified to be installed over a residential hot tub and under important installation instructions issued by Covana. Any other type of usage will void the warranty and product certification. The power safety cover meets the ASTM F1346-91 requirements.

⚠ DANGER

- ◆ To reduce the risk of injury, do not allow children to use this product unless they are supervised at all times.
- ◆ The Covana cover should be fully visible when operating the key switch.
- ◆ Failure to follow all the instructions may result in injury or even death.
- ◆ Inspect the cover periodically. It should raise smoothly and evenly. Contact your Covana dealer if any unusual mechanical sound is heard during use.
- ◆ Never operate the Covana cover until all people and objects are out of the spa.
- ◆ Do not operate the Covana cover while in the hot tub.
- ◆ Lower the Covana in extreme wind conditions. Gusts of 30 mph (50 km/h) while in the raised position and upwards of 45 mph (70 km/h) when completely lowered on the hot tub.

⚠ WARNING

- ◆ Do not allow people to climb on the cover.
- ◆ Do not allow children to have access to the Covana cover without supervision.
- ◆ Be sure to keep the key switch and the key out of the reach of children.

- ◆ Do not put any type of fabric or plastic sheet, such as a tarpaulin, on the Covana cover. This could overheat the cover and result in the deformation or delamination of the cover.

DO

- ◆ Remove the control key after operating the Covana cover. Store the key in a secure location when not in use. Users must bring the control key in the hot tub with them to prevent unauthorized operation of the cover.
- ◆ Check the cover frequently for signs of deterioration.
- ◆ Have any repairs, adjustments or mechanical work performed by your certified Covana dealer as soon as possible when you notice a malfunction.
- ◆ Close the cover when it is not in use or if the hot tub is not being monitored.

DO NOT

- ◆ Operate the unit before all the mechanical and electrical connections have been made.
- ◆ Step on or stack anything on the operator.
- ◆ Operate the Covana cover while somebody is in the hot tub.
- ◆ Sit, step or walk on the Covana cover at any time.
- ◆ Leave the Covana cover open for more than 12 hours at a time. This could cause the cover to warp.
- ◆ Converge or directly reflect sunlight on the cover. This could cause permanent damage.
- ◆ Wash the cover with harsh chemicals or cleaners.
- ◆ Use a pressure washer to clean any component of the Covana cover. This could result in premature wear or damage.
- ◆ Use an extension cord to connect the Covana cover to its power source. The cord may not be properly grounded and the connection is a shock hazard. An extension cord may cause a voltage drop, which would cause the motor to overheat.

CAUTION

- ◆ Be sure to follow all the instructions in this manual and only use the accessories and tools approved by Covana.
- ◆ Do not roll the Covana cover onto its side or slide it on its side. This will damage the siding.
- ◆ After removing a part, always place it in a safe place on a clean and level surface to ensure proper functionality.
- ◆ *For anchoring model:* All post of the Covana cover must be properly anchored to the foundation using the anchoring holes located at the foot of each post.
For tub mount model: All posts of the Covana cover must be properly anchored to the hot tub frame using the tub mount brackets and arms.
- ◆ This product mainly contains steel, fiberglass, foam, copper (Cu) and die-cast aluminum (Al). The gearbox contains oil and other materials. Please recycle them properly.
- ◆ Both the up and down limit switches are pre-adjusted at the factory. The down-limit switch should never be readjusted. The up-limit switch should be readjusted only to reduce the maximum height of the cover to avoid possible contact with its surroundings. Please refer to the Limit Switch Adjustment section in this manual before making any adjustments. An improper adjustment can result in damage to the drive system and/or cover.

Avoiding the risk of electrocution

ELECTRICAL DANGER

- ◆ Failure to comply with these instructions may result in death by electrocution or serious injury. Disconnect or turn off and secure the power supply before starting any intervention on the Covana cover.
- ◆ Always have a licensed electrical contractor perform any electrical maintenance or repairs on the Covana cover. The wiring must comply with all the applicable local electrical codes and regulations.

- ◆ The Covana operator must be connected to a circuit that is protected by a dedicated ground fault circuit interrupter (GFCI) that complies with all the applicable local electrical codes and regulations.
- ◆ Install the Covana cover in such a way that drainage directs water away from the electrical components.
- ◆ Do not connect any auxiliary components to the electrical system of the Covana cover unless they have been approved by Covana.
- ◆ Replace electrical components with original components provided or approved by Covana. Ask your dealer for replacement parts.

ELECTRICAL WARNING

- ◆ To reduce the risk of electric shock, the green-colored terminal or the terminal marked “g,” “gr,” “ground,” “grounding” or with a \equiv symbol that is located inside the supply terminal box or compartment must be connected to the grounding means provided in the electric supply service panel with a continuous copper wire equivalent in size to the circuit conductors supplying the equipment.
- ◆ Two lugs marked “bonding lugs” are provided on the external surface or on the inside of the supply terminal box or compartment. To reduce the risk of electric shock, connect the local common bonding grid in the area of the Covana cover. Use terminals with an insulated or bare copper conductor no smaller than No. 6 AWG (13.3 mm²).
- ◆ To reduce the risk of electrical shock, replace any damaged cord immediately. Failure to do so may result in death or serious personal injury due to electrocution.
- ◆ All field-installed metal components, such as rails, ladders, drains or other similar hardware, within 10 ft. (3 m) of the hot tub must be bonded to the equipment grounding bus with copper conductors not smaller than No. 6 AWG (13.3 mm²). (NEC art. 680.)

⚠ WARNING REGARDING DRUG OR ALCOHOL USE

- ◆ The use of drugs or alcohol while operating the Covana cover is strictly prohibited. The impairment of judgment, vision or hearing might affect the security of other people or result in death.

⚠ WARNING REGARDING MODIFICATIONS TO THE COVER

- ◆ Any modifications to the Covana cover, such as mechanical, electrical or aesthetic ones, may cause the cover to operate in an unwanted or dangerous way. Furthermore, these modifications are not permitted and might void the warranty and certification.

LABELLING



Risk of electrocution warning, found on the operator unit.

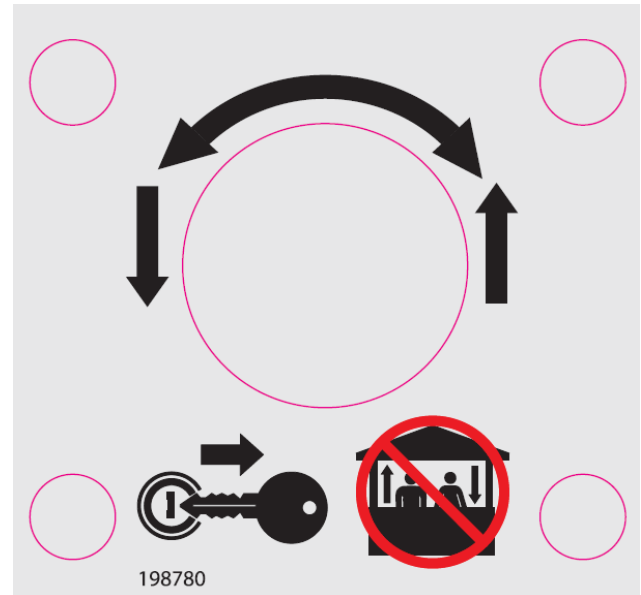

Key operating diagram, found on the key switch.



Drowning risk warning, found on the outside of the Covana cover.

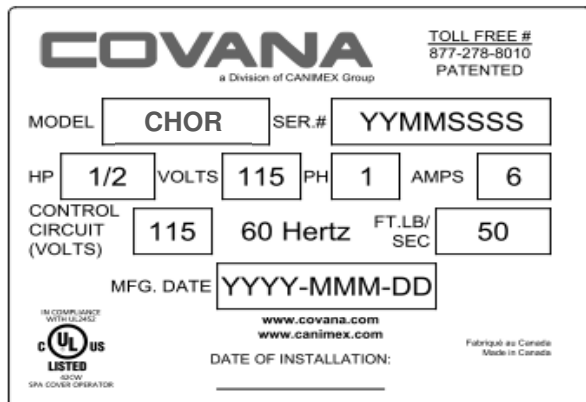

Specification sticker, found on the operator. (North American model)

Note: This sticker provides the serial number

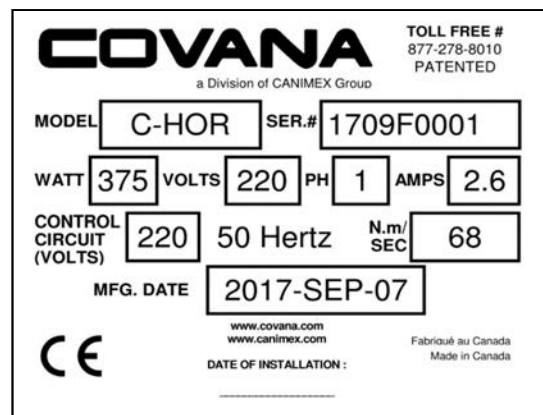

Specification sticker, found on the operator. (European model)

Note: This sticker provides the serial number

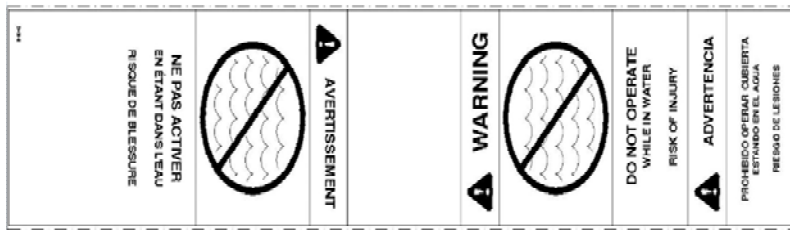

Sticker found on the key switch cable.



200350

Do not step or stand on symbol, found on top of the operator unit.



Sticker found on the C-channels.

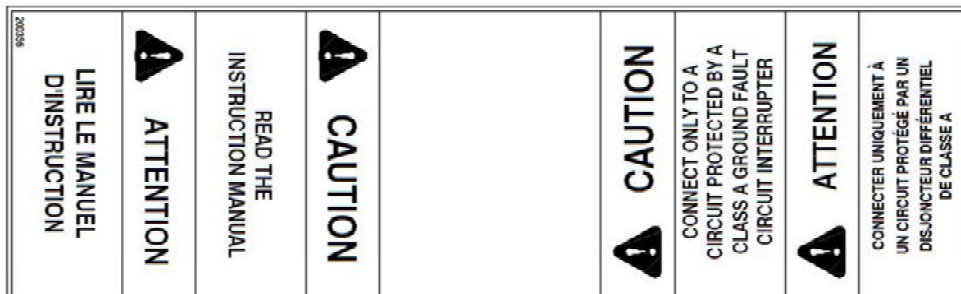

Electrical information, found on the key switch cable.

**DO NOT STEP ON COVER.
NE PAS MONTER SUR LE COUVERCLE.**

211118

Do not step or stand on the cover sticker found at the end C-channels of the Covana cover (hidden when assembled).

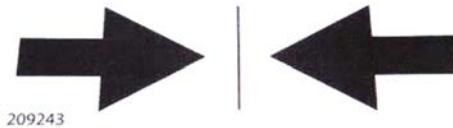











Centre sticker found on the centre of the 81 7/16 in. (207 cm) C-channels.









Top sticker, found on the interior of the I-beams and escape hatch opening to indicate orientation (hidden when assembled).





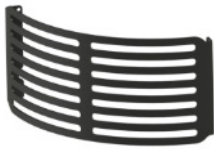

GLOSSARY

Part	Figure	Function
Post	 <p data-bbox="505 795 581 821">Figure 1</p>	<p>The posts will be fastened to the cover and will allow it to raise or lower.</p>
All weather seal	 <p data-bbox="505 1016 581 1041">Figure 2</p>	<p>The all-weather seal will protect sleeves from damages due to weather.</p>
Top plate	 <p data-bbox="513 1329 589 1354">Figure 3</p>	<p>The top plate is a cover that is installed on the sleeve assembly.</p>
Operator unit	 <p data-bbox="513 1600 589 1625">Figure 4</p>	<p>The unit powers and controls the lifting mechanism of the Covana cover.</p>



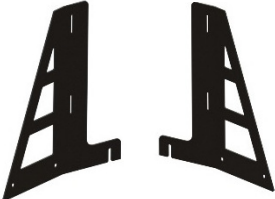





<p>Drive shaft</p>	 <p>Figure 5</p>	<p>The drive shaft transmits the power between the jack assemblies.</p>
<p>U frame (short)</p>	 <p>Figure 6</p>	<p>The short U frames protect the drive shafts. They are fastened to the bottom of the posts and to the long U frame.</p>
<p>Motor-side</p>	 <p>Figure 7</p>	<p>The motor-side protect the chains. It is fastened to the short U frames and to the operator.</p>
<p>Corner cover</p>	 <p>Figure 8</p>	<p>The corner cover protects the link between the short U frames and the long U frame.</p>
<p>Pivot arm</p>	 <p>Figure 9</p>	<p>Links the cover to the posts.</p>
<p>C channel</p>	 <p>Figure 10</p>	<p>The C-channel is the outer frame of the cover. The panels are installed between the C-channels</p>

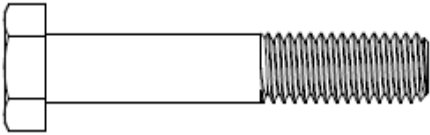

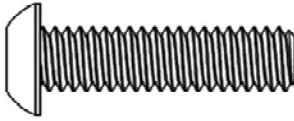

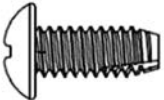

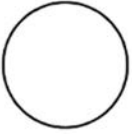
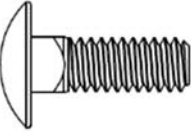
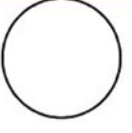
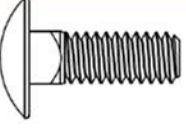

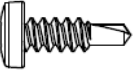
<p>I beam</p>	 <p>Figure 11</p>	<p>The I-beam is the aluminum extrusion installed between the panels.</p>
<p>I to C bracket</p>	 <p>Figure 12</p>	<p>The I-to-C bracket makes the link between I-beam and C-channels.</p>
<p>Key switch</p>	 <p>Figure 13</p>	<p>The key switch is used to operate the Covana cover.</p>
<p>Corner bracket</p>	 <p>Figure 14</p>	<p>The corner brackets link the C-channels on the side to the ones in front and back.</p>
<p>Corner cover</p>	 <p>Figure 15</p>	<p>The corner cover is an aesthetic aluminum grid fixed to the corner bracket.</p>
<p>Escape hatch</p>	 <p>Figure 16</p>	<p>The escape hatch is a removable door part of the cover.</p>

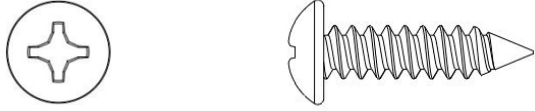







<p>Contour seal</p>	 <p>Figure 17</p>	<p>The contour seal ensures uniform contact between the cover and the tub.</p>
<p>Contour seal connector</p>	 <p>Figure 18</p>	<p>The seal connector is used to link both ends of the seal. It ensures a strong and effective joint.</p>
<p>Contour seal installation clip</p>	 <p>Figure 19</p>	<p>Contour seal installation clips are used during the installation process to ensure the seal is installed properly.</p>
<p>Wiper bracket</p>	 <p>Figure 20</p>	<p>The wiper bracket is adhered under the I-beam. This part is required to ensure waterproofing of the Horizon cover.</p>
<p>Installation foam</p>	 <p>Figure 21</p>	<p>The installation foam is used during the installation process to protect the tub from direct contact with the cover.</p>
<p>Sleeve bracket</p>	 <p>Figure 22</p>	<p>Used for the standard tub mount option to mount the sleeves to the tub. It is the part lying against the sleeves.</p>

<p>Tub mount support</p>	 <p>Figure 23</p>	<p>The tub mount supports are used to mount the sleeves to the tub. It is the part lying against the tub.</p>
<p>Tub mount arm (short or long)</p>	 <p>Figure 24</p>	<p>The tub mount arms are used for the tub mount option only. They link the sleeve brackets to the tub mount supports.</p>
<p>Post brackets (optional)</p>	 <p>Figure 25</p>	<p>Assembled with the L brackets, the side supports and the linkage bars, the post brackets allow posts' stability without the need to mount any hardware to the tub.</p>
<p>L bracket (optional)</p>	 <p>Figure 26</p>	<p>Assembled with the post brackets, the side supports and the linkage bars, the L brackets allow posts' stability without the need to mount any hardware to the tub.</p>
<p>Side support (optional)</p>	 <p>Figure 27</p>	<p>Assembled with the L brackets, the post brackets and the linkage bars, the side supports allow posts' stability without the need to mount any hardware to the tub.</p>
<p>Linkage bar (optional)</p>	 <p>Figure 28</p>	<p>Assembled with the L brackets, the side supports and the post brackets, the linkage bars allow posts' stability without the need to mount any hardware to the tub.</p>

HARDWARE IDENTIFICATION TABLE

Quantity	Visual representation		Description
<p>4x Non-painted</p> <p>2x Painted</p>			5/16"-18 x 2" hexagonal bolt used to fasten the short and long U-frames. Painted bolts are used for the short U-frames' fixations to the posts and non-painted bolts are used under the U-frames' covers.
2x			1/4in. -20 x 1 in. Button hex drive bolt. Used for the pivot arms' assembly.
<p>10x Stabilization</p> <p>2x Tub mount</p>			10-24 x 1/2 in. Thread cutting screw. Used on the U-frames' corner covers. These screws are also used on the side supports for the stabilization feet option.
24x			#8 x 3/4 in. Sheet metal screw. Used to fasten the corner brackets and the corner covers of the Horizon cover.
<p>4x Stabilization</p> <p>28x Tub mount</p>			1/4 in.-20 x 5/8 in. Carriage bolt. Used for fastening the I-beam assemblies. These bolts are also used for the tub mount option.
<p>16x Stabilization</p>			1/4 in.-20 x 3/4 in. Carriage bolt. Only used for the stabilization option.
4x			#8 x 1/2 in. Self-drilling screw. Used to fasten the top plates.

<p>32x Tub mount</p>		<p>#10-12 x 3/4 in. self-tapping screws. Only used for tub mount option.</p>
<p>4x Stabilization 28x Tub mount</p>		<p>1/4 in. Lock washer used for cover assembly and the tub mount option.</p>
<p>8x Tub mount</p>		<p>1/4 in. Flat stainless steel washer. Only used for tub mount option.</p>
<p>2x</p>		<p>5/16 in. Lock washer used to fasten the operator unit to the long U-frame.</p>
<p>2x</p>		<p>5/16 in. Flat stainless steel washer used to fasten the operator to the long U-frame.</p>
<p>4x</p>		<p>5/16 in. Flat nylon washer used on the visible fixations of the short U-frames.</p>
<p>8x Stabilization</p>		<p>0.192-0.450-0.050 in. Flat zinc plated washer only used for the stabilization option.</p>
<p>4x Stabilization 28x Tub mount</p>		<p>1/4 in.-20 Hex nut. Used for cover assembly and the tub mount option.</p>

<p>2x</p>		<p>5/16 in.-18 Hex nut. Used to fasten the operator to the long U-frame.</p>
<p>4x Non-painted 2x Painted</p>		<p>5/16 in.-18 Nylon insert locknut. Used to fasten the short and long U-frames. Painted nuts are used for the short U-frames' fixations to the posts and non-painted nuts are used under the U-frames' covers.</p>
<p>4x Stabilization</p>		<p>1/4 in.-20 Nylon insert locknut. Only used for the stabilization option.</p>
<p>2x</p>		<p>1/4-20-5/16 in. Set screw used on the operator's sprocket.</p>
<p>4x</p>		<p>5/16-18-5/16 in. Set screw used on the pivot arms.</p>
<p>1x</p>		<p>3/16-3/16-5/8 in. Square ends key used for the operator's sprocket.</p>
<p>2x</p>		<p>1/4-1/4-1 in. Square ends key used for the pivot arms.</p>
<p>1x</p>		<p>5/32 in. Hex key. Used for fastening the 1/4in.-20 x 1 in. Button hex drive bolts.</p>

INSTALLATION PREPARATION

To ensure the safe use of the Horizon cover, it must be installed on a properly prepared surface. It is important to adequately prepare the foundation and carefully read the following recommendations.

Location considerations

- ◆ Ensure the future Horizon cover location is not subjected to water downpour or debris falling from another rooftop.
- ◆ Ensure that the base of the cover is not in a flood zone. Any damage caused by flooding or water accumulation will not be covered under the warranty.
- ◆ Ensure that there are no obstacles, such as branches or electrical power lines, in the operating range of the cover.
- ◆ Refer to section *Technical specifications* for cover dimensions.
- ◆ Ensure there is safe access to the tub, free of obstacles or debris.
- ◆ All the base components of the Horizon cover must be supported by the foundation.

- ◆ Do not concentrate or directly reflect sunlight onto the cover. This could cause permanent damage (e.g. reflection from a window).
- ◆ Ensure the Horizon cover is installed on a clean surface free of any vegetation, such as grass, branches, roots or mineral contaminants, such as rocks, dust or sand.
- ◆ The key switch must be permanently mounted and located 5 ft. (1.5 m) away from the tub and 5 ft. (1.5 m) above the deck or ground level. This ensures the user has a clear view of the Horizon cover when operating it. Furthermore, the key switch terminal should be located in a place where no water downpour or debris could fall on it. (Figure 29)

⚠ WARNING

- ◆ Failure to permanently install the key switch as indicated could cause serious injury or even death and void the warranty and certification. Only the proper installation of the key switch combined with the suggested procedures and caution will reduce such risks.
- ◆ Do not place the cover in an area prone to snow accumulation or water runoff.

⚠ DANGER

- ◆ Failure to properly install the key switch according to these instructions could result in injury or even death.

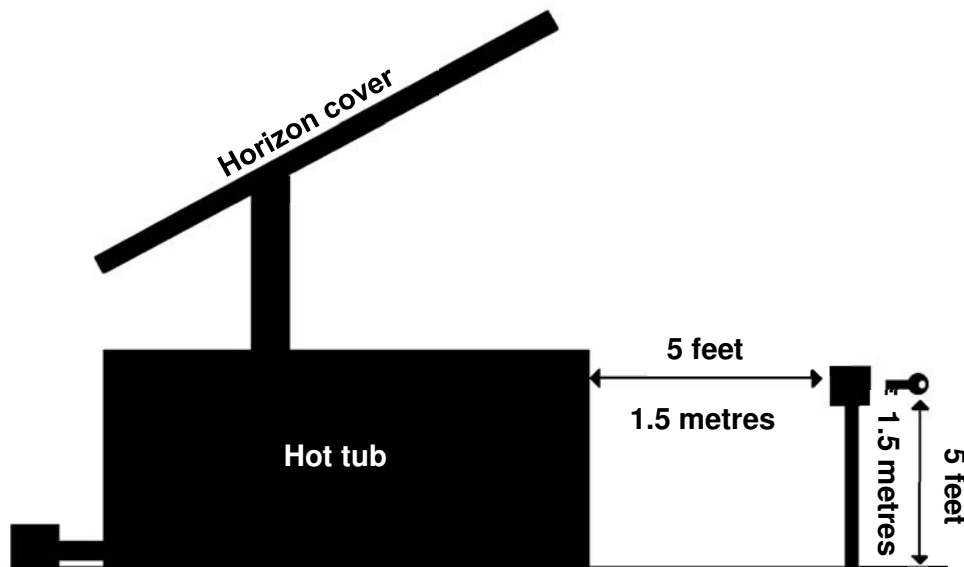

Figure 29

Foundation preparation

- ◆ The Horizon cover requires a clean, flat and level surface such as an engineered wood deck or a concrete slab.
- ◆ Each of the two jacks of the Horizon cover must be properly fastened to the tub frame. It is the installers responsibility to ensure the Horizon cover is properly fastened and in a safely manner.
- ◆ Covana offers the ground anchoring option for the Horizon. It is the installer's responsibility to ensure the Horizon cover is properly anchored to the ground with the proper anchoring hardware.

⚠ WARNING

- ◆ The ground anchoring option should not be used in an extremely windy area.
- ◆ Just like the tub, the Horizon cover requires a solid foundation. The foundation for the Horizon cover must be able to support at least 650 lb. (295 kg).
- ◆ The foundation must be levelled with a maximum tolerance of 1 in. (2.5 cm) over a 113 3/4 in. (2.89 m) by 53 in. (1.35 m) rectangle (Figure 30). The annual variation in levelness for the same area cannot exceed 1/4 in. (6 mm).

⚠ CAUTION

- ◆ Damage caused by inadequate foundation construction is not covered by the Covana warranty. It is the responsibility of the owner to provide a proper foundation.
- ◆ Failure to follow these guidelines might cause permanent damage or the improper functioning of the Covana cover. Such damage might not be covered by the warranty.

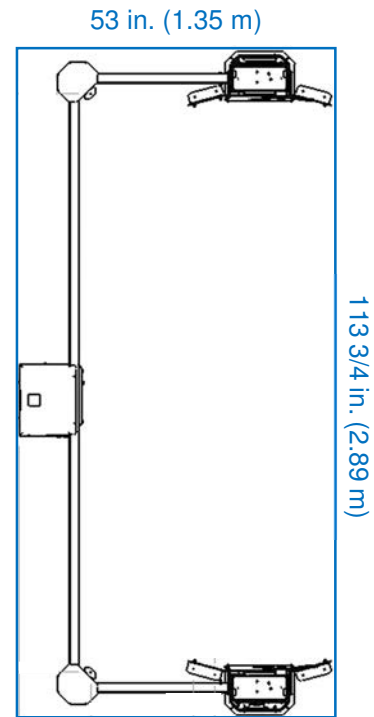

Figure 30

Installation information

Throughout the following installation instructions, we will refer to the front, rear, left and right sides of the spa. Please refer to Figure 31 and Figure 32. The front of the spa is the side of the higher point of the tilt and the back of the spa is the operator's side.

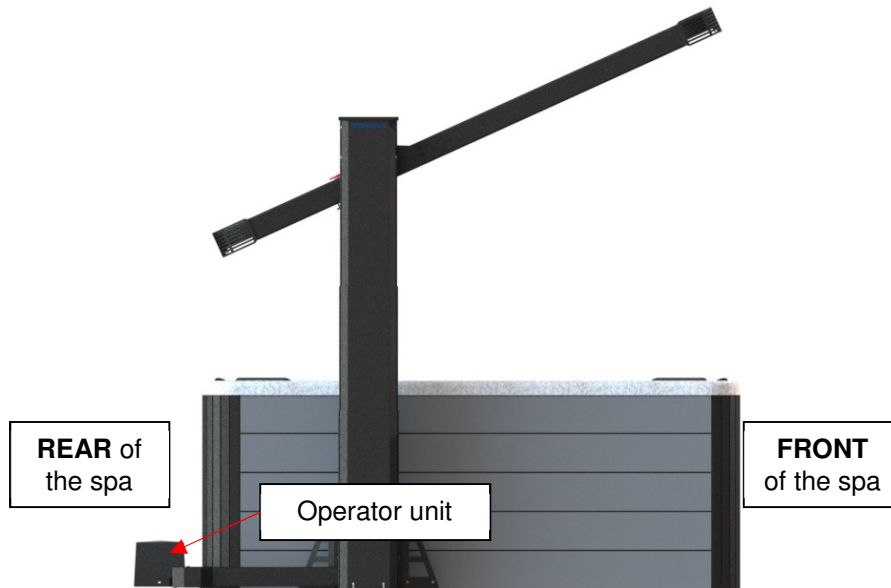

Figure 32



Figure 31

INSTALLATION

Required tools for complete installation

- ◆ Scissors or a retractable utility knife
- ◆ Robertson screwdriver
- ◆ Rubber mallet
- ◆ Hammer
- ◆ Phillips screwdriver
- ◆ Stepladder
- ◆ 1/8" (3 mm) Allen key
- ◆ 9/16" (14 mm) socket wrench and spanner
- ◆ 7/16" (11 mm) socket wrench and spanner
- ◆ 1/2" (13 mm) socket wrench and spanner
- ◆ 5/32" (4 mm) Allen key (Supplied)
- ◆ 26' (8 m) measuring tape
- ◆ SAE or metric Socket kit
- ◆ 48 in. (122 cm) level

Uncrating

- 1) Before uncrating the unit, ensure there is no visible damage to the crate. In case of any suspicious damage, take photos first. If any damage is discovered, please call Covana customer service immediately.
- 2) Always stand the crate in the vertical position. Ensure wind conditions allow for this to be done safely.
- 3) Remove the cardboard top. You might need a stepladder to reach it. (Figure 33)
- 4) Unscrew the #8-10 x 1.5 in. Robertson screws holding the front cover – 5 screws per side. (Figure 33)
- 5) Remove the front cover and discard. (Figure 33)

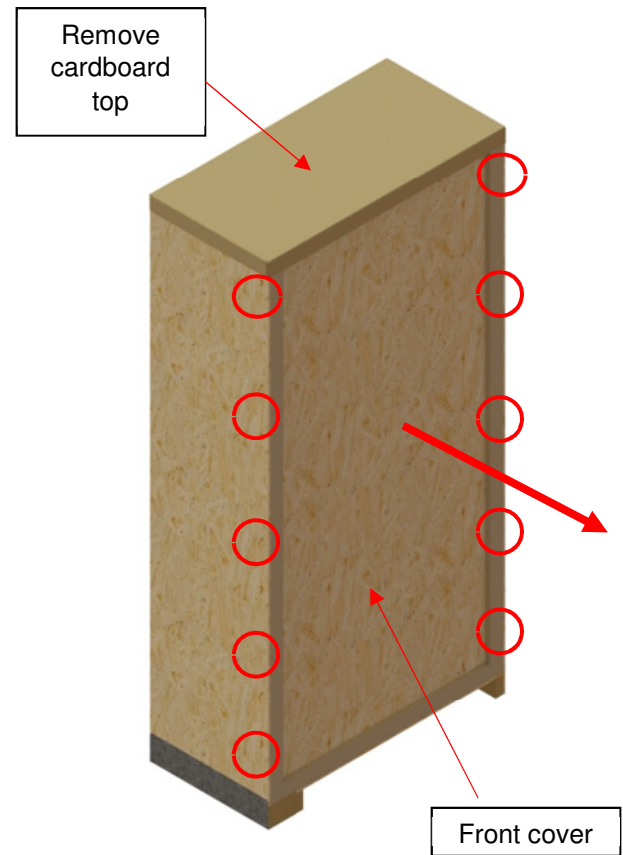

Figure 33

6) Remove the seal, the foam spacers and the optional part box, either the tub mounting or the ground anchoring hardware, from the bottom of the crate and place them in a safe place. (Figure 34)

7) Unscrew the two #10 x5/8 in. Phillips screws on the motor-side support, cut the tie wrap holding the long U-frame to the stud, remove the motor-side from the crate and place it in a safe place. (Figure 34)

8) Unscrew the two #8-10 x 1.5 in. Robertson screws on the operator base plate, remove the operator from the crate and place it in a safe place. (Figure 35)

9) Remove both U-frames at the bottom of the crate and place them in a safe place. (Figure 36)

10) Unscrew the bottom #8-10 x 1.5 in. Robertson screws holding the posts to the crate. There are two bottom screws per posts as shown in Figure 36.

⚠ CAUTION

- ◆ Be careful while manipulating any painted components to avoid any scratches on the surface.

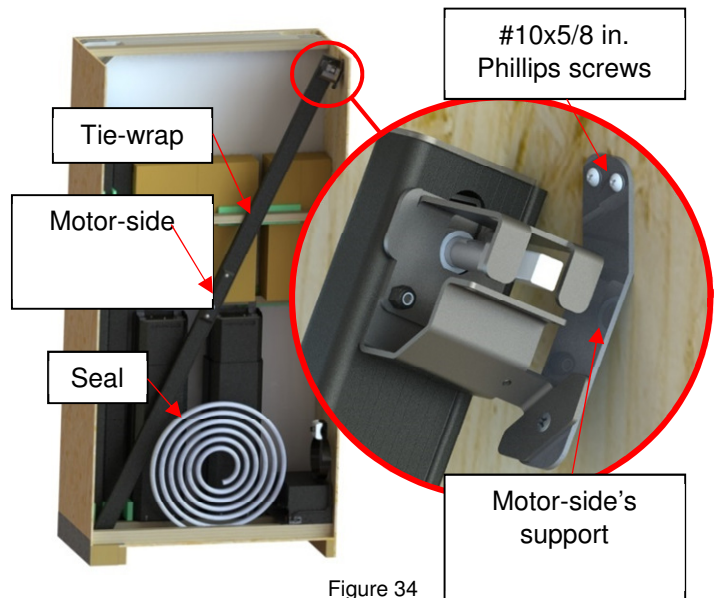

Figure 34

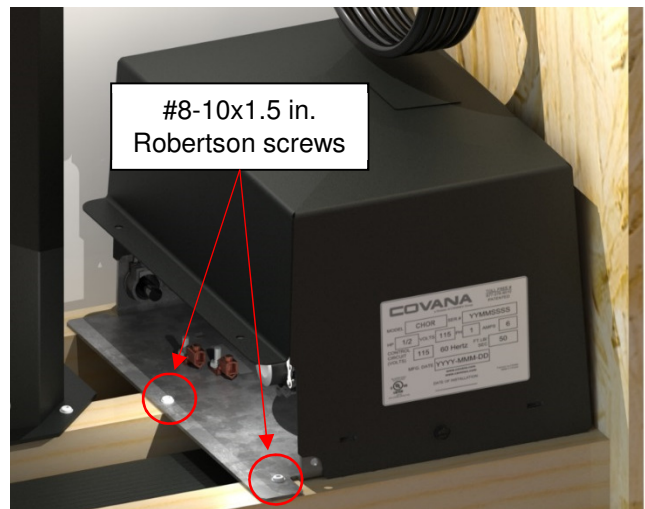

Figure 35

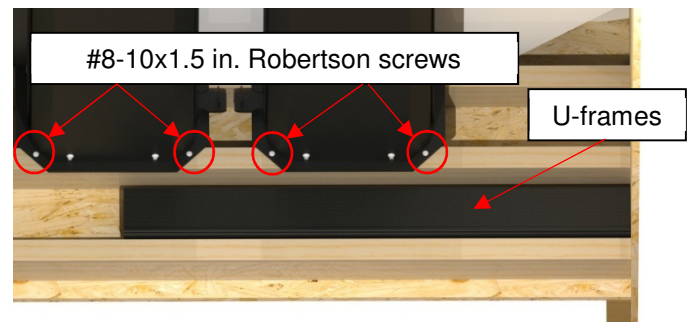

Figure 36

- 11) Unscrew the top #8-10 x 1.5 in. Robertson screws holding the posts to the crate as shown in Figure 37.
- 12) Remove both posts from the crate and store them in a safe place.

⚠ WARNING

- ◆ The posts are heavy. Two people might be needed to perform this.

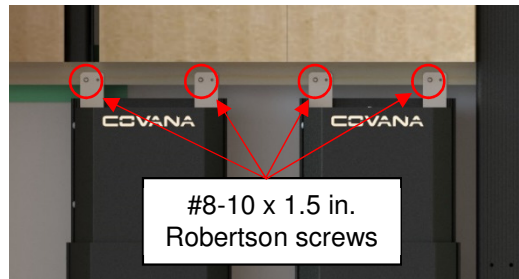

Figure 37

- 13) Remove the posts' support brackets by unscrewing the #8x1/2 in. Robertson screw on each bracket (two support brackets per post) from the posts. (Figure 38)
- 14) With the help of another person, lay the crate horizontally on its back. There should be one person on each side of the crate. (Figure 39)

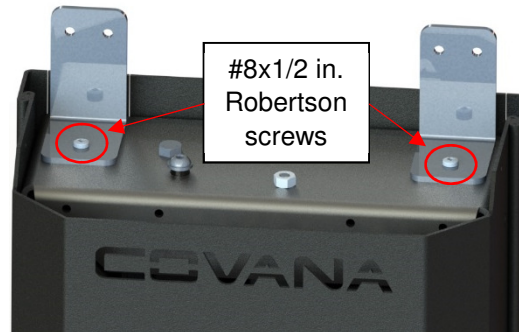

Figure 38

⚠ WARNING

- ◆ The crate is heavy; you may require a third person to rotate the crate.

- 15) Remove the stud over the parts boxes and the other components by unscrewing the #8-10 x 1.5 in. Robertson screws on both sides of the crate. (Figure 40)
- 16) Remove the part boxes and store them in a safe place.
- 17) Cut the tie-wrap holding the I beam and the C-channels on the middle 2 x 3 in. stud, remove them from the crate and store them in a safe place. (Figure 40)
- 18) Remove the two studs holding the fibreglass panels in the crate. (Figure 40)
- 19) Leave both fibreglass covered foam panels in the crate and until they are needed. (Figure 40)



Figure 39

⚠ WARNING

- ◆ Panels are fragile. Handle them with care to ensure that they are not scratched or damaged.

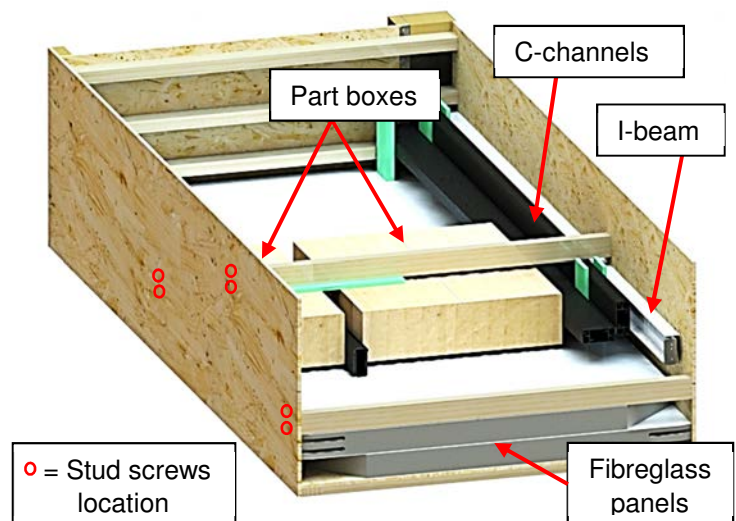

Figure 40

Cover assembly

⚠ WARNING

- ◆ Before assembling the cover, keep in mind not to overtighten bolts. Power tools **must not** be used. The bolts will break or strip under too much torque.
- 1) Attach the installation foam spacers to the top of the hot tub near each corner using the masking tape provided in the part box. There must be at least two foam spacers per side. Do not stack two pieces of foam. (Figure 41)

⚠ CAUTION

- ◆ The foam pieces must be placed on the flat top surface of the hot tub.
- 2) Put the escape hatch panel on the rear end of the hot tub. (Figure 42)
 - 3) Remove the foam pieces on the escape hatch panel.

⚠ CAUTION

- ◆ Ensure that the seal around the escape hatch opening is on top and that the top sticker located in the panel's hole is pointing upwards.
- 4) Untighten the 1/4-20-1 in. button head screws on the 81 7/16 in. (207 cm) C-channels. Ensure there is a gap of approx. 1/2 in. (12.7 mm) between the screws' heads and the C-channels. (Figure 43)

⚠ CAUTION

- ◆ Do not fully remove the screws.
- 5) Assemble the short C-channels, approx. 81 7/16 in. (207 cm), over the previously placed fiberglass panel so that the middle of the C-channels, pre-marked with a centre sticker (Figure 50), is aligned with the edge of the panel. Ensure the screws untightened at step 4 are uncentered toward the rear of the spa. It is recommended to slightly engage the top flange before the bottom when sliding the C-channel onto the foam panel. (Figure 43)

⚠ WARNING

- ◆ When assembling the C-channel onto the panel, be careful not to delaminate the fiberglass.



Figure 41

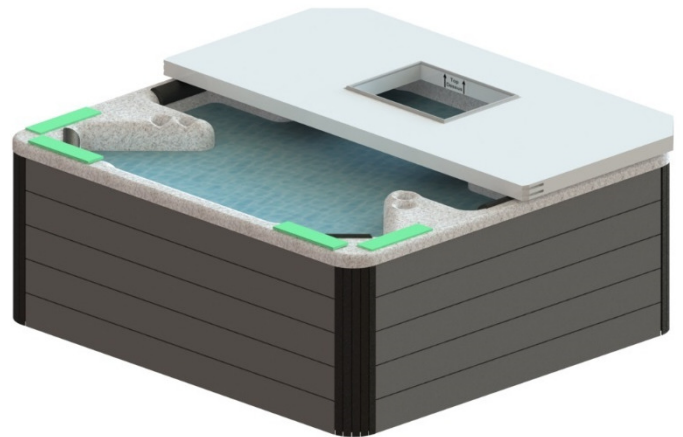

Figure 42

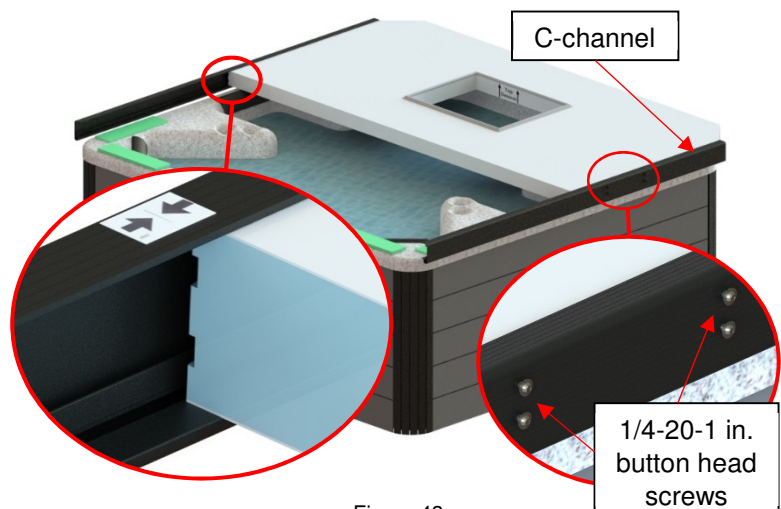

Figure 43

- 6) Install the I to C bracket to the I-beam by using 1/4 in.-20 x 5/8 in. carriage bolts, 1/4 in. lock washers, 1/4 in.-20 nuts and 7/16 (11 mm) socket wrench and spanner. Leave a 1/4 in. (6 mm) gap in-between the small I to C-bracket and bent part. (Figure 44)

⚠ CAUTION

- ◆ The I to C channel connections must be installed at both sides of the I-beam.
- ◆ Ensure these bolts and nuts are slightly untightened, leave a **1/4 in. (6 mm) gap** between the I to C-bracket and plate.

- 7) Slide the I-beam with the I to C brackets in the C-channels as shown in Figure 47. Place the I-beam in such a manner where the bent portion of I to C connection is pointing outwards. (Figure 48) Ensure it fits snug with the foam panel. Ensure the sticker in the I-beam is pointing upwards. (Figure 45)

⚠ CAUTION

- ◆ Ensure the upright position of the I-beam.
- ◆ Ensure the proper insertion of the I to C bracket in the C-channel. (Figure 48)
- ◆ When inserting the I-beam into the fibreglass foam panel, ensure not to chip the fibreglass.
- ◆ Ensure the I-beam has cleared the bottom and top section.

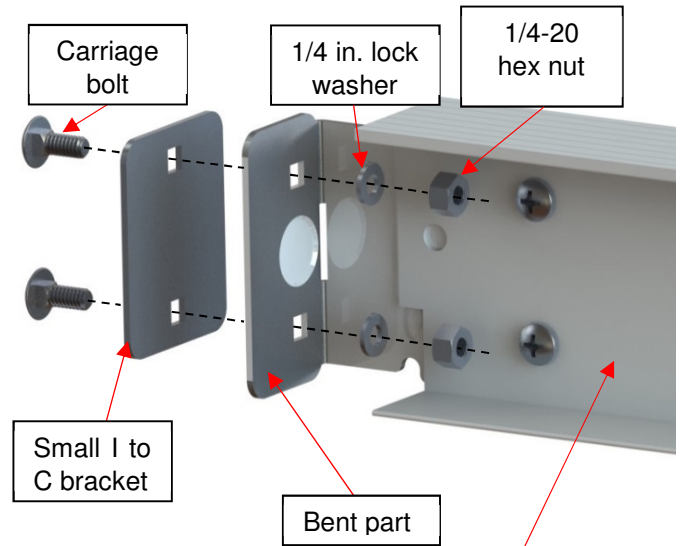

Figure 44



Figure 45



Figure 46

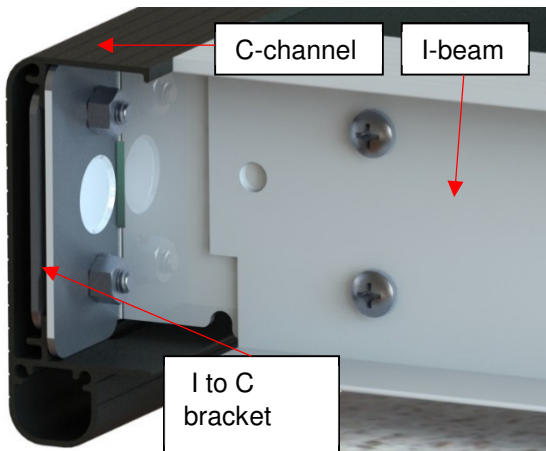

Figure 48

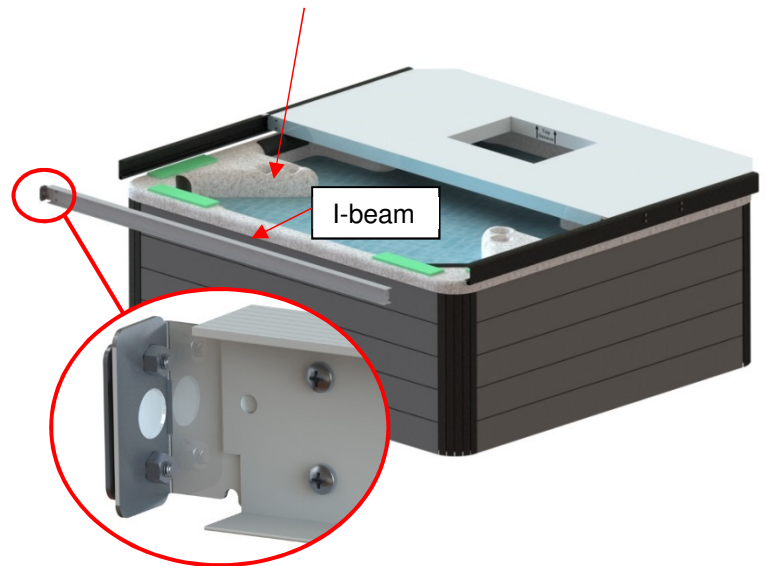

Figure 47

- 8) Once the I-beam is properly centred into the C-channels using the center sticker (Figure 49), lock it in place by tightening the four nuts and carriage bolts on both sides of the I-beam (two on each side). (Figure 50)

⚠ WARNING

- ◆ Do not to overtighten bolts. Power tools must not be used. The bolts will break or strip under too much torque.

- 9) Slide the remaining panel into the C channels and press it slightly against the I-beam. (Figure 51)

⚠ CAUTION

- ◆ Ensure not to delaminate the panel while sliding it into the C-channels.

- 10) Insert the two corner brackets on the tapered parts of the front fibreglass panel. Use the provided Robertson sheet metal #8 x 3/4 in. screws on the inside holes on both sides of the cover. **The two remaining holes will be used later.** (Figure 52)

⚠ CAUTION

- ◆ Do not tighten any of these screws yet.

TOP VIEW

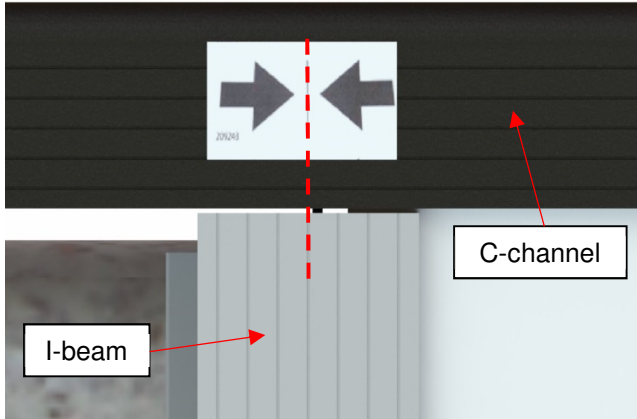

Figure 49

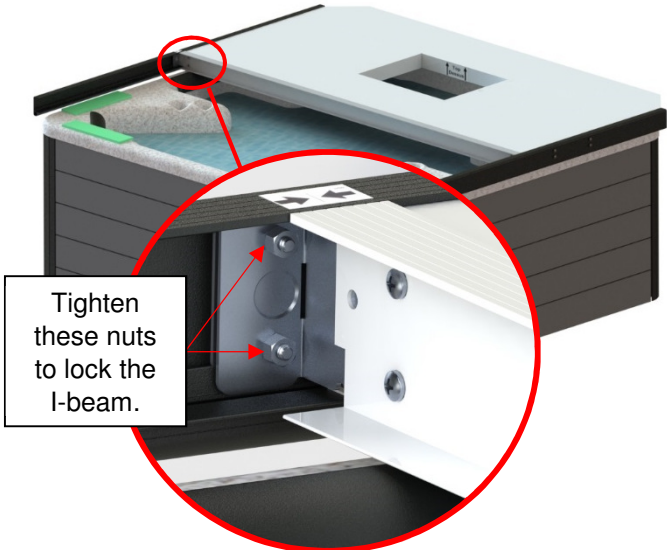

Figure 50

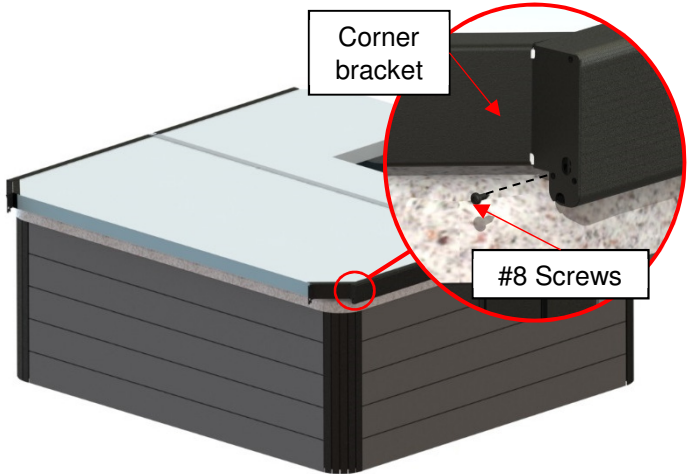

Figure 52

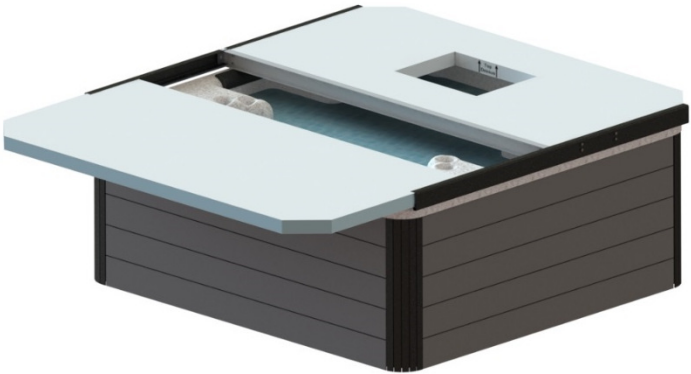

Figure 51

11) Snap on a remaining side C channel, 83 3/4 in. (213 cm) at the end of the front panel. It is recommended to slightly engage the top flange before the bottom when sliding the C-channel onto the foam panel. (Figure 53)

12) Screw in the second Robertson sheet metal #8 x 3/4 in. screws in the inner holes of the corner brackets on both sides of the cover. (Figure 53)

⚠ CAUTION

- ◆ Do not tighten any of these screws yet.

13) Install the right corner cover by screwing the four #8 x 3/4 in. screws (two screws on each side of the corner cover) to the C-channels. (Figure 54 and Figure 55)

14) Install the left corner cover on the other side of the cover. (Figure 54 and Figure 55)

⚠ CAUTION

- ◆ Do not tighten any of these screws yet.

15) Repeat steps 10 to 14 for the rear side of the cover. (Figure 56)

16) Once all four corner brackets and corner covers are installed, tighten all the screws.

⚠ WARNING

- ◆ Do not to overtighten bolts. Power tools must not be used. The bolts will break or strip under too much torque.

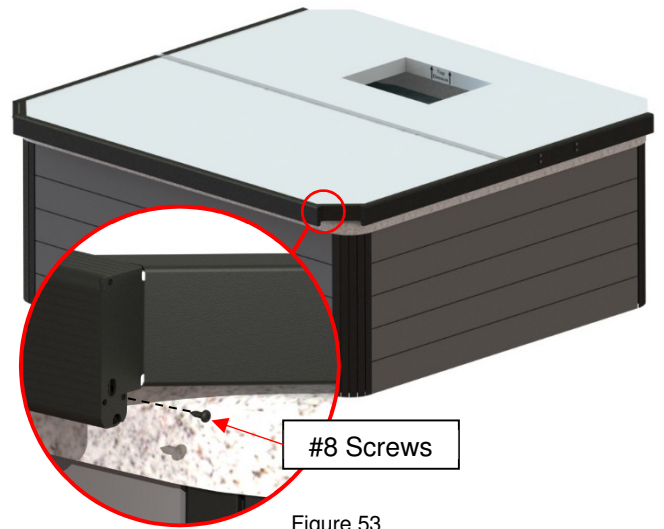

Figure 53

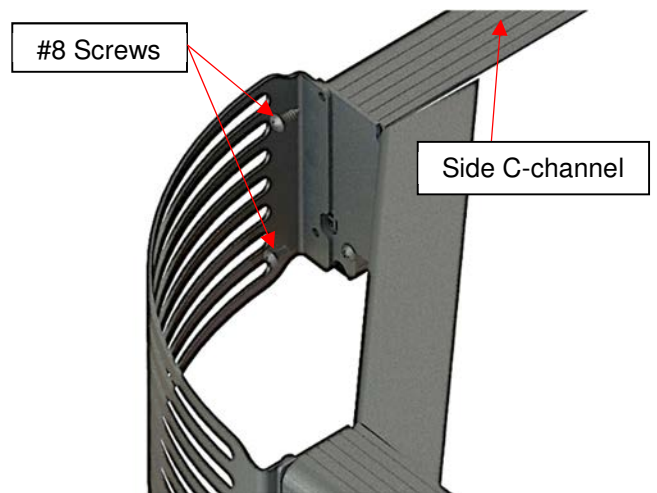

Figure 54

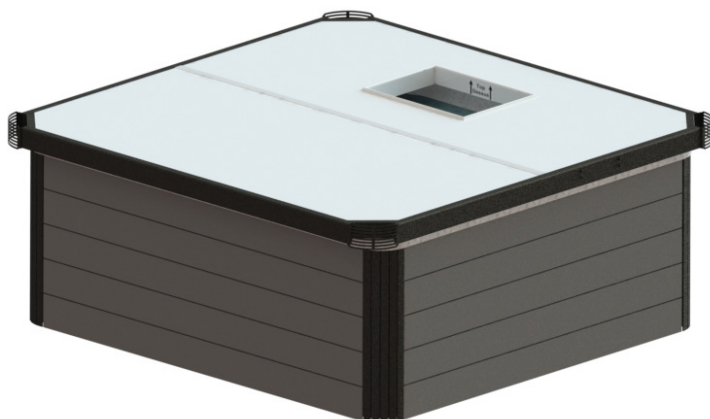

Figure 56

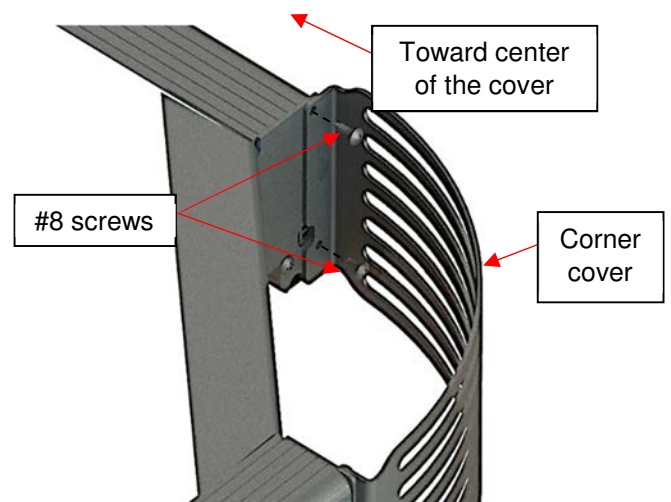

Figure 55

- 17) Turn the escape hatch handle to retract the arms and install it into the escape hatch opening of the panel. (Figure 57)

⚠ CAUTION

- ◆ Verify the functionality of the escape hatch's release mechanism prior to installation and before use. Please ensure that the hatch's arms are retracted when open and non-retracted when closed. (Figure 58)

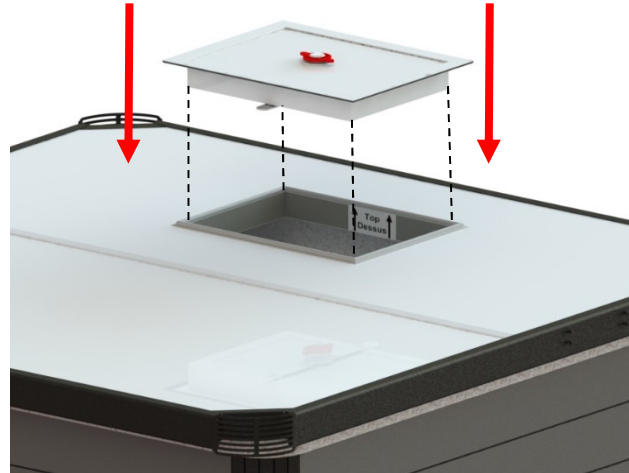

Figure 57

⚠ WARNING

- ◆ Failure to install the escape hatch properly may impede performance of the Covana cover such as vapor leakage, water infiltration and unwanted access to hot tub.
- ◆ All security risks such as drowning, injury or undesired entry due to an open Covana cover without an escape hatch installed are not approved by Covana and product certification will be void.

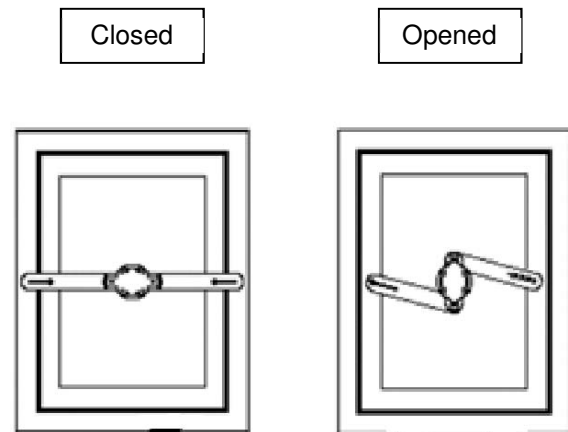

Figure 58

Tub mount assembly

Note: If the optional ground anchoring brackets are supplied, skip to next section.

- 1) Untighten the four top 1/4-20-1/2 in. Phillips screws to have an approx. 1/4 in. (6.35 mm) gap between the heads of the screws and the sleeve. (Figure 59)

⚠ CAUTION

- ◆ Do not fully remove the screws. Failure to follow this instruction will cause damage to the posts.
- 2) Untighten the two bottom 1/4-20-1/2 in. Phillips screws to have an approx. 1/4 in. (6.35 mm) gap between the heads of the screws and the sleeve. (Figure 59)

⚠ CAUTION

- ◆ Do not fully remove the screws. Failure to follow this instruction will cause damage to the posts.
- 3) Slide both the top and bottom sleeve brackets in between the appropriate screws and the sleeve. Ensure the sleeve brackets are well centred with the post. (Figure 60)
 - 4) Tighten all six screws. (Figure 60)

⚠ WARNING

- ◆ Do not overtighten any hardware. Failure to follow this instruction might damage the paint or the hardware itself.
- 5) Repeat steps 1 to 4 for the second post.

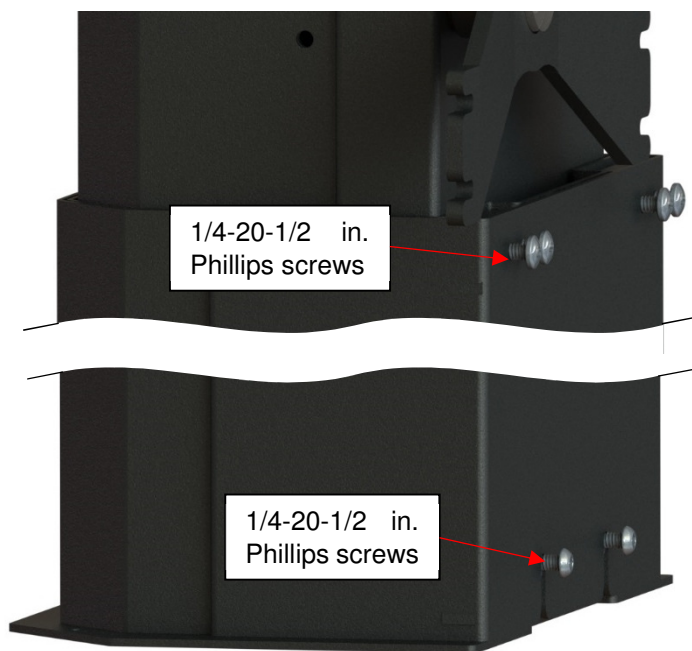

Figure 59

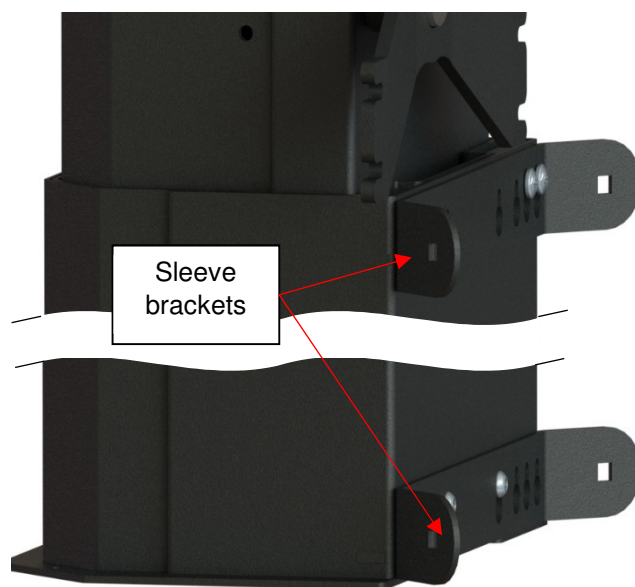

Figure 60

Post ground anchoring bracket assembly (optional)

- 1) Attach the L bracket on the post bracket with included 1/4-20-3/4 in. carriage bolts and 1/4-20 nylon hex lock nuts. (Figure 61)

Note: Depending on the space between the tub and the posts or the location chosen for the tub, the L brackets can be fastened on any side of the post bracket. See Figure 69 to see all the configuration possibilities.

⚠ WARNING

Do not overtight any hardware. Failure to follow this instruction might damage the paint or the hardware itself.

- 2) Repeat for all four post brackets.
- 3) Insert a side support in the slots of the post bracket and insert 1/4-20-3/4 in. carriage bolts in both holes. (Figures 62 and Figure 63)
- 4) Repeat for all four sides supports. Ensure both brackets are installed as shown in Figure 63.

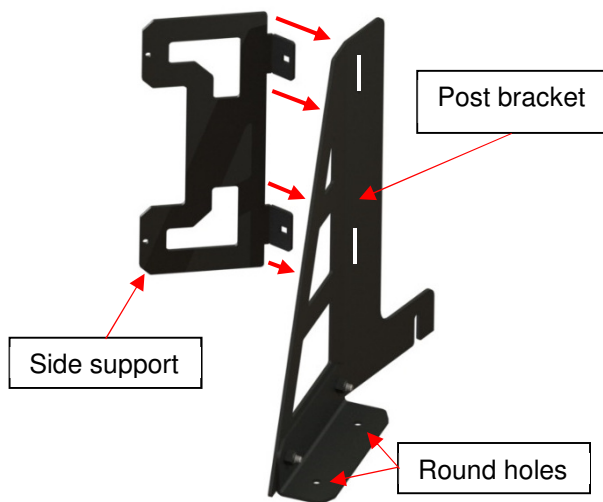
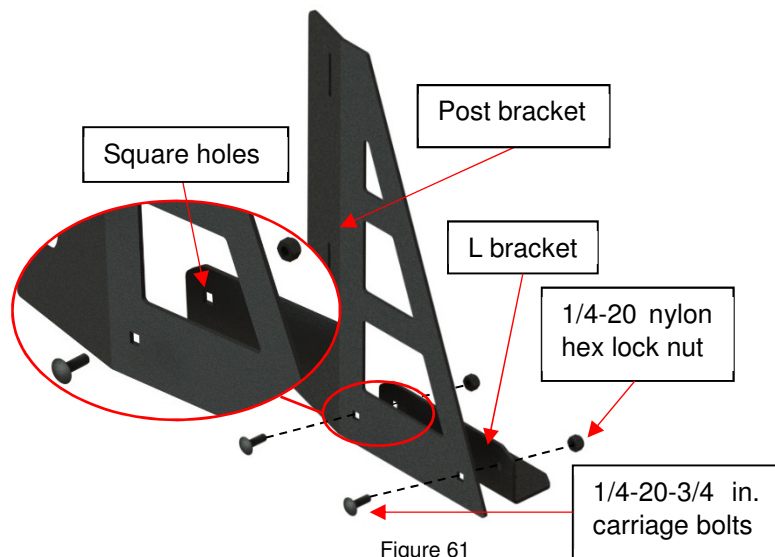

Figure 62

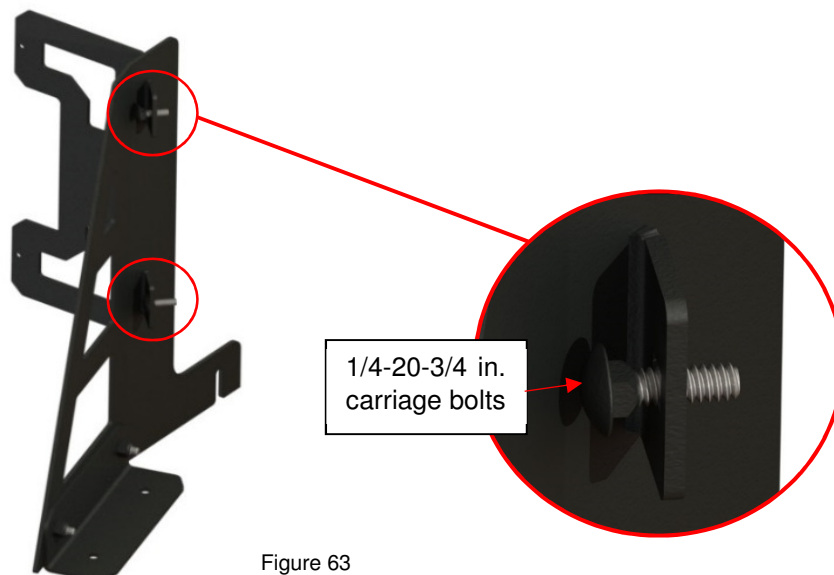

Figure 63

- 5) Link the right and left support brackets with the linkage bar with the included 1/4-20 nylon hex lock nuts and carriage bolts. Leave these loose. (Figure 64)
- 6) Repeat for second assemblies.
- 7) Carefully lay the post on the ground. Ensure the back of the post with the post support assembly is on top. (Figure 66)

⚠ WARNING

- ◆ Be careful while manipulating the posts. They are heavy and damage or injuries might occur if they are dropped.
- 8) Untighten the two 1/4-20-1-1/2 in. Phillips screws at the bottom part of the post until the gap between the outer sleeve and the head of the screws is large enough to slide the post support assembly in. (Figure 65-66)

⚠ CAUTION

- ◆ Ensure you do not totally unscrew these screws. Leave an approx. 1/4 in. (6.35 mm) between the head of the screws and the sleeve. Failure to follow this instruction might damage the posts.
- 9) Place the first post support assembly behind the first post. Leave the screws loose. (Figure 65-66)

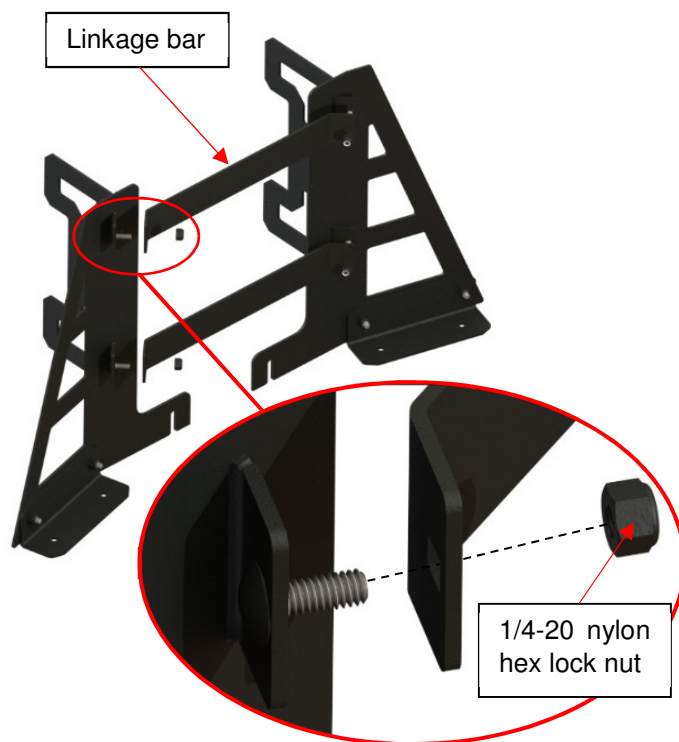

Figure 64

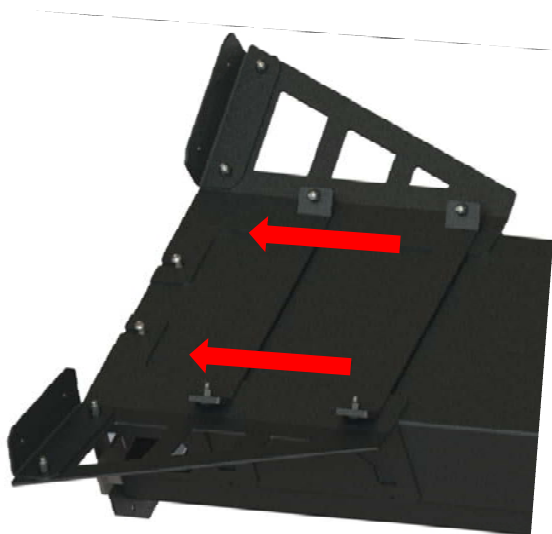

Figure 65

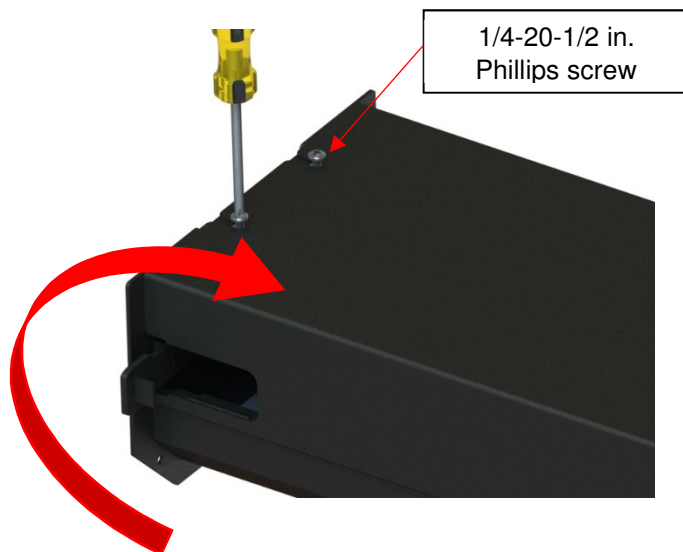

Figure 66

10) Remove the four hole caps on the sides of the post.

11) Secure both side brackets with two 10-24 x 1/2 in. thread cutting Phillips screws and 0.192-0.450-0.050 in. washers. Ensure to use the correct washers (thickness: ~0.05-0.062 in) and do NOT overtighten. (Figure 67)

⚠ WARNING

- ◆ Ensure the 0.192-0.450-0.50 in. washers are positioned as shown in Figure 67. Failure to follow this instruction will damage the middle sleeve.

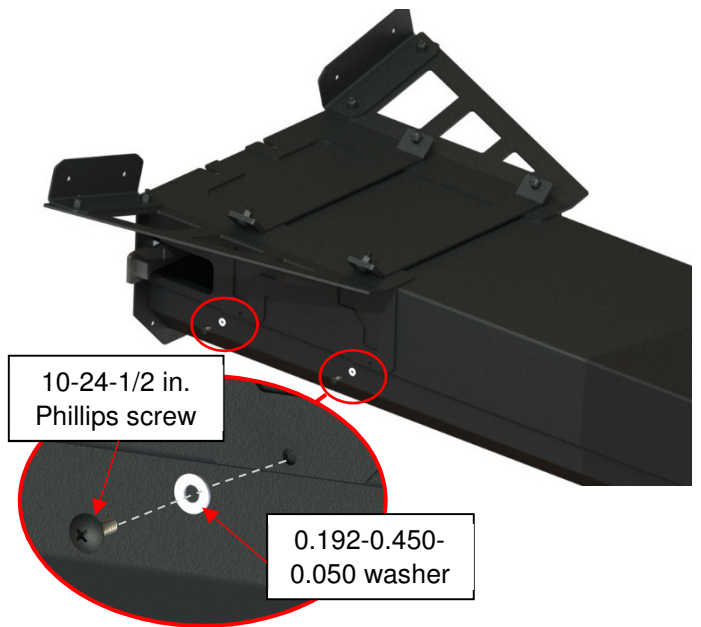

Figure 67

12) Tighten all bolts and nuts installed from steps 3 to 8. (Figure 68)

13) Repeat steps 8 to 12 for the second post and flip both posts back on their feet.

Note: Figure 69 illustrates the three configuration possibilities for the post ground anchoring bracket assembly.

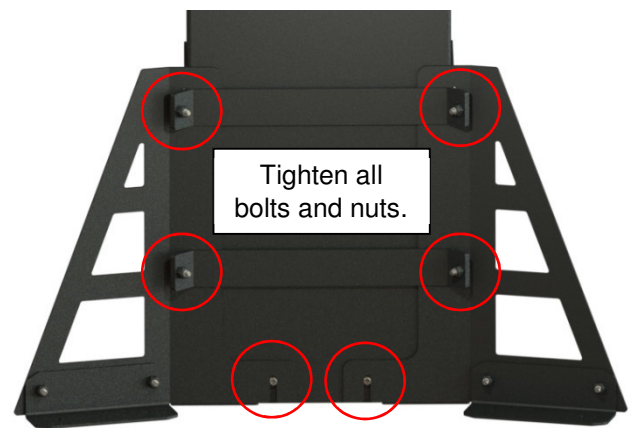

Figure 68



Figure 69

Post assembly

- 1) Insert the pivot arm on the shaft behind the first post. For tubs from 36 in. (91.4 cm) high and below, place the pivot arm with the V pointing up and for tubs above 36 in. (91.4 cm) high, place the pivot arm with the V pointing down. (Figure 71)
- 2) Install the 1/4-1/4-1 in. key in the shaft's keyway located on the post. (Figure 70)
- 3) Put the painted washer on and screw the 1/4-20-1 in. button head screw with the provided 5/32 in. hex key. (Figure 72)
- 4) Tighten both pivot arm's 5/16-18-5/16 in. set screws with the provided 5/32 in. hex key. (Figure 72)
- 5) Repeat steps 1 to 4 for the second post.
- 6) Place the two posts at the required position next to the spa and align the holes in the pivot arms with those on the side of the cover frame. (Figure 73) Both openings for the drive shafts at the bottom of the posts should be pointing toward the rear side of the spa.

Note: There may be a difference in height between the pivot arms and the cover frame. It will be adjusted at a later step. Only the vertical alignment is important at this point.

⚠ CAUTION

- ◆ The posts are heavy, be careful while manipulating them.

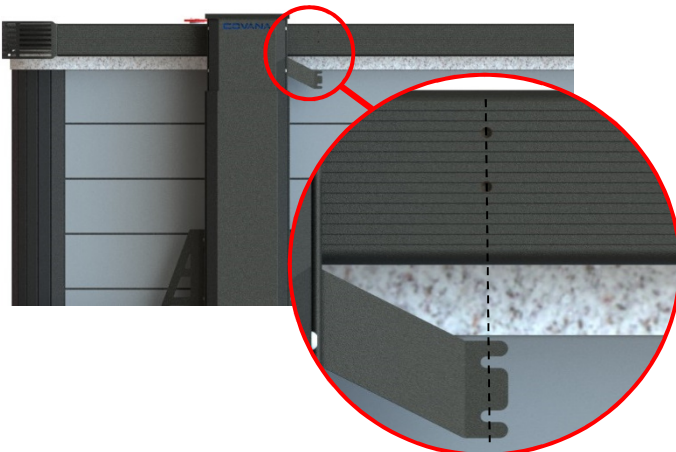

Figure 73

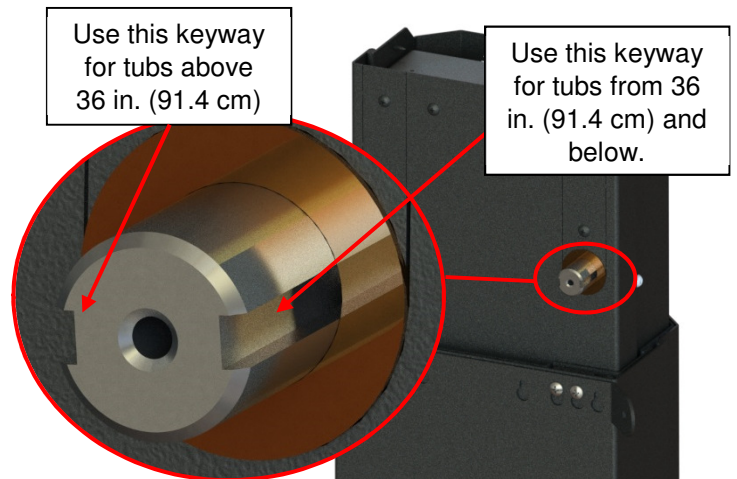

Figure 70

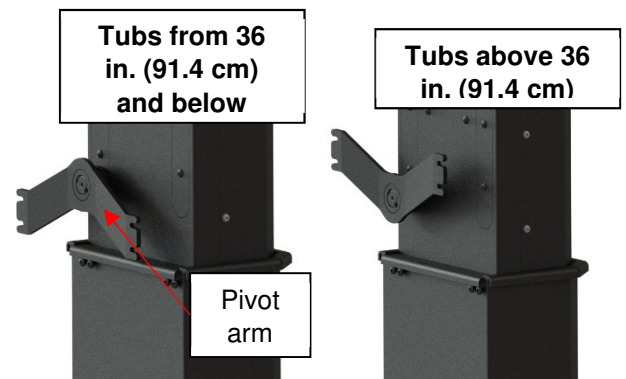

Figure 71

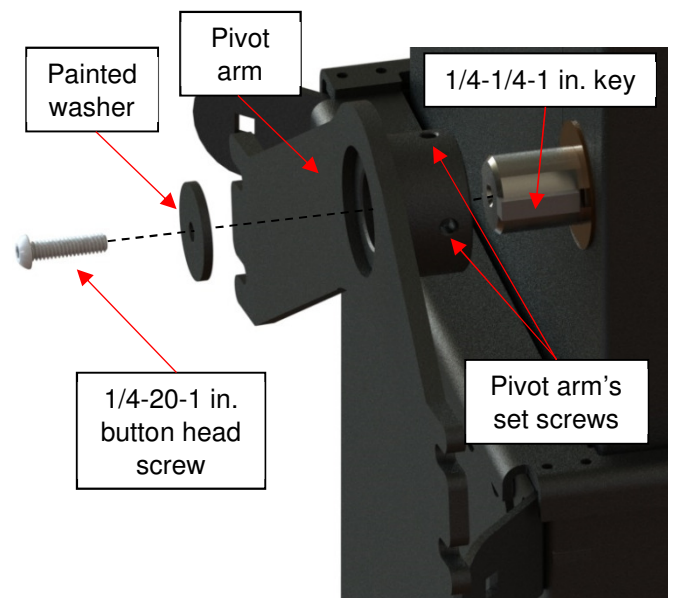

Figure 72

Lifting mechanism assembly

- 1) Insert the square drive-shaft over the square shaft on the bottom of the jack by the opening in the bottom of the post and push it as far as possible. (Figure 74)
- 2) Slide a short U-frame over the first square drive-shaft and push it as deep as possible in the opening at the bottom of the post. (Figure 75)

Note: The U-frame end that has one hole must go toward the post and the end that has 2 holes must go toward the rear of the spa.

⚠ CAUTION

- ◆ Ensure the U-frame is fully inserted into the post so its length out is 25 in. (63.5 cm).
 - ◆ Ensure the U-frame's extrusion is well inserted in the footplate insert as shown in the detail view of the Figure 75.
 - ◆ Be careful not to damage the paint on the U-frame or the outer sleeve while inserting the U-frame into the post.
- 3) Secure it in place by putting a painted 5/16-18-2 hex cap screw through the hole, put a painted 5/16-18 nylon nut from the other side and 5/16 nylon washers on both sides. (Figure 76). Ensure the 5/16-18-2 hex cap screw is positioned as shown in Figure 77.

⚠ CAUTION

- ◆ Do not overtighten the screws or use any power tools as it might break the U frame or the hardware itself.
- 4) Repeat step 1 to 3 for the second post.



Figure 74

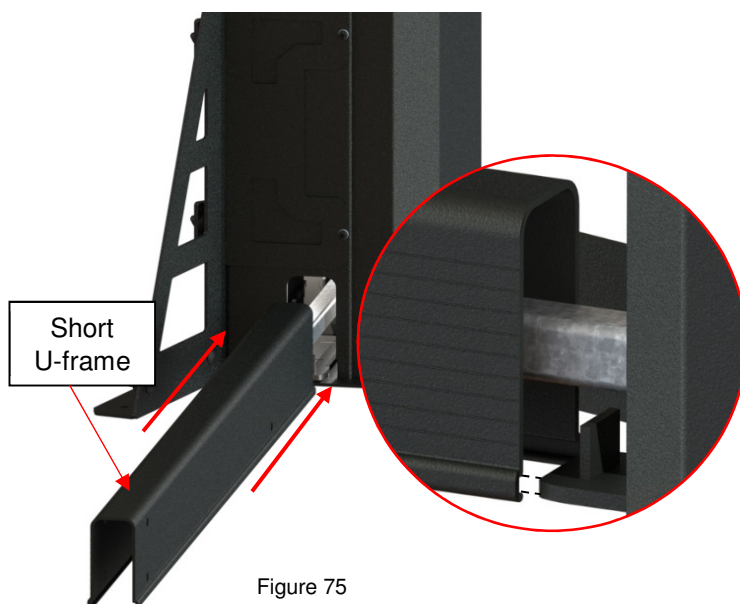

Figure 75



Figure 78

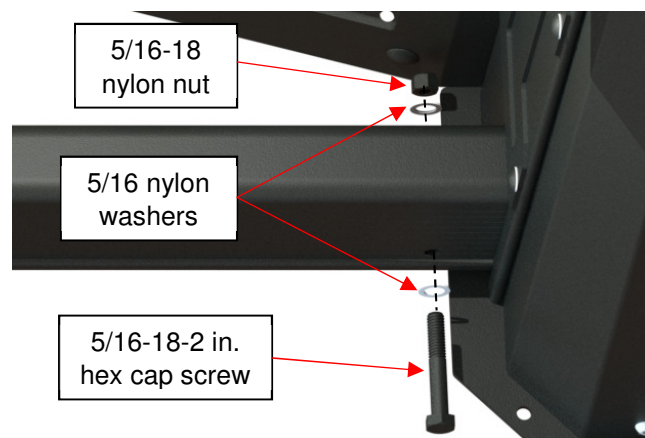

Figure 76

5) Unscrew the crating bracket on the corner bracket of the motor-side. (Figure 34)

6) Place the motor-side along the rear of the spa with each end next to the two square drive-shafts installed previously. (Figure 78)

⚠ CAUTION

- ◆ Ensure the input shaft in the middle of the U frame is pointing outwards from the spa.
- ◆ Ensure the keyway of the motor-side's input shaft is pointing upwards.

7) Slide the other end of the left square drive-shaft over the square shaft located at the end of the motor-side. (Figure 79)

Note: You might need to rotate the output shaft of the motor-side assembly so both output shaft and drive shaft align well. If so, proceed as shown in Figure 79 using an adjustable wrench to rotate the output shaft.

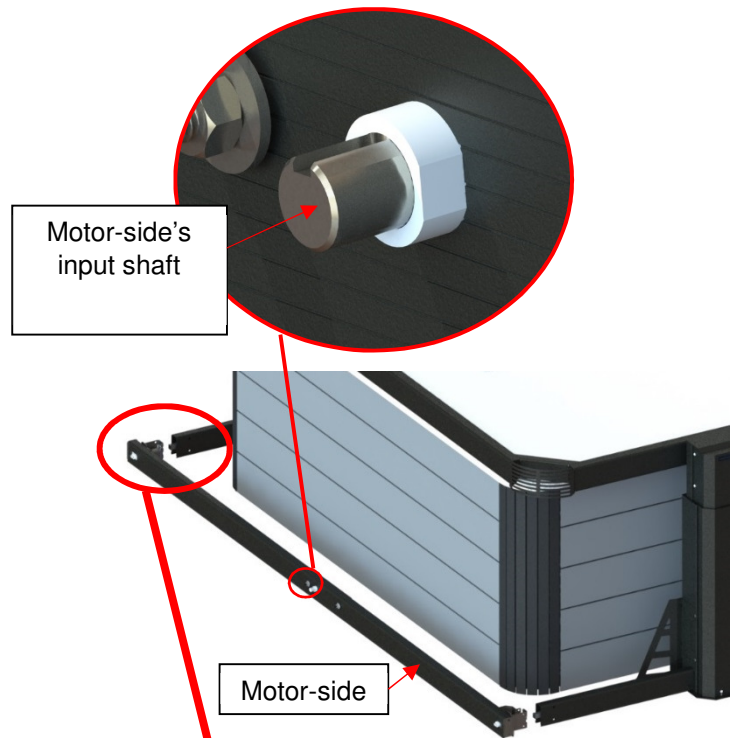

Figure 79

⚠ CAUTION

- ◆ Do not turn the shaft more than a 1/8" [3.175 mm] of a turn. Failure to follow this instruction might break components in the posts.

8) Repeat step 7 for the right side.

9) Ensure that the holes on the short U-frame are aligned with those on the corner bracket.

10) Secure everything in place by sliding a 5/16-18-2 hex cap screw through each of the 2 holes and put a 5/16-18 hex lock nut from the other side. (Figure 80)

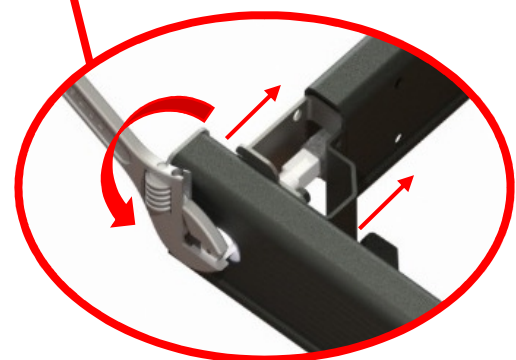

Figure 80

⚠ CAUTION

- ◆ Do not overtighten the screws or use any power tools as it might break the U-frame or the hardware itself.

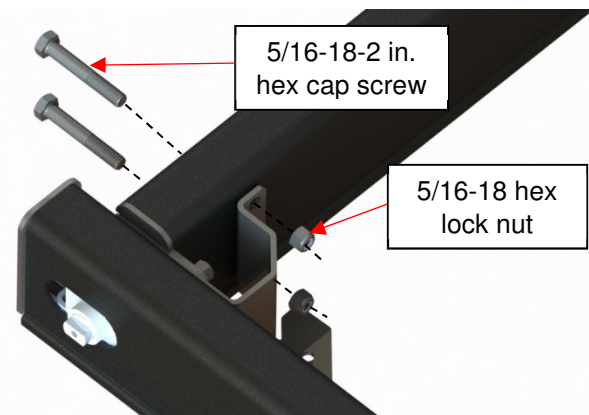

Figure 81

- 11) Slide the corner cover over the junction between the 2 U-frames and secure it in place with the painted #10-24-1/2 in. Phillips screw. (Figure 81)
- 12) Repeat steps 9 to 11 on the opposite side.
- 13) Remove the four slotted screws at the bottom of the operator and remove the cover. Do not discard these screws. (Figure 82)
- 14) Install the 3/16-3/16-5/8 in. key into the long U-frame's input shaft's keyway. (Figure 83)
- 15) Remove the tape on the operator's sprocket.
- 16) Untighten the set screws of the operator's sprocket.
- 17) Align the keyways of the input shaft and operator's sprocket together by turning the hex shaft of the gearbox. (Figure 83)
- 18) Insert the motor-side's input shaft into the sprocket.
- 19) Fasten the operator to the two bolts of the long U-frame with a 5/16 in. flat washer, 5/16 in. lock washer and a 5/16-18 hex nut. (Figure 84)
- 20) Tighten both set screws in the sprocket. (Figure 84)

⚠ CAUTION

- ◆ Do not overtighten the set screws or use any power tools as it might damage some components.

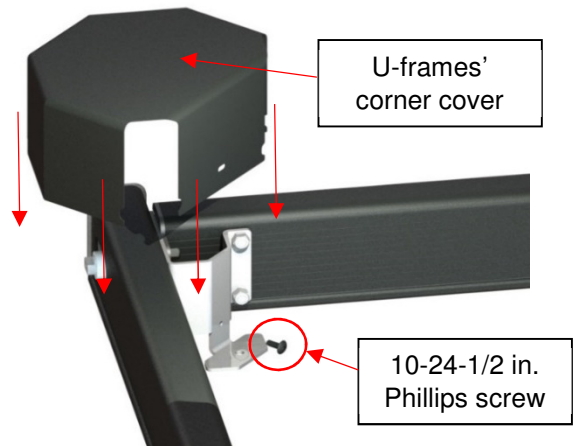

Figure 82

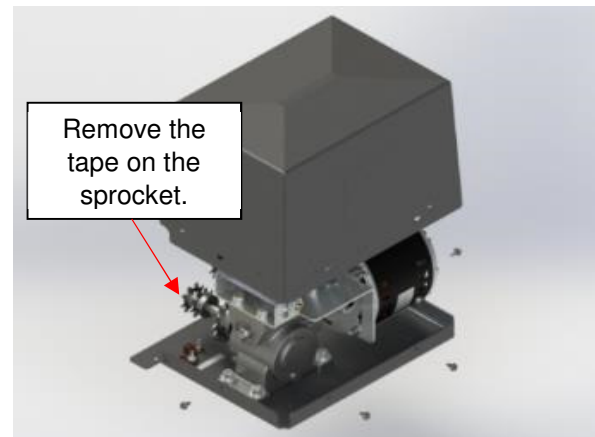

Figure 83

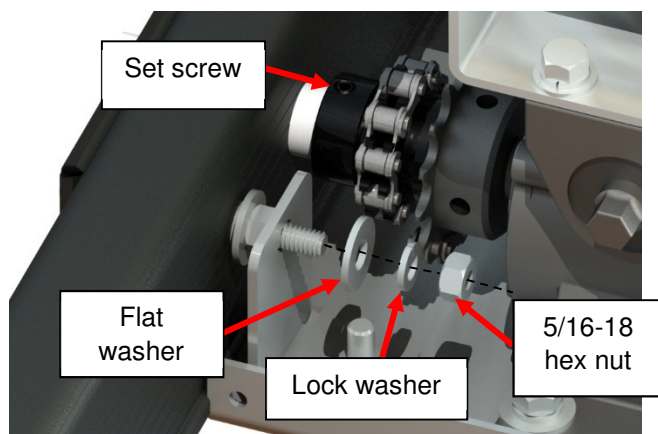

Figure 84

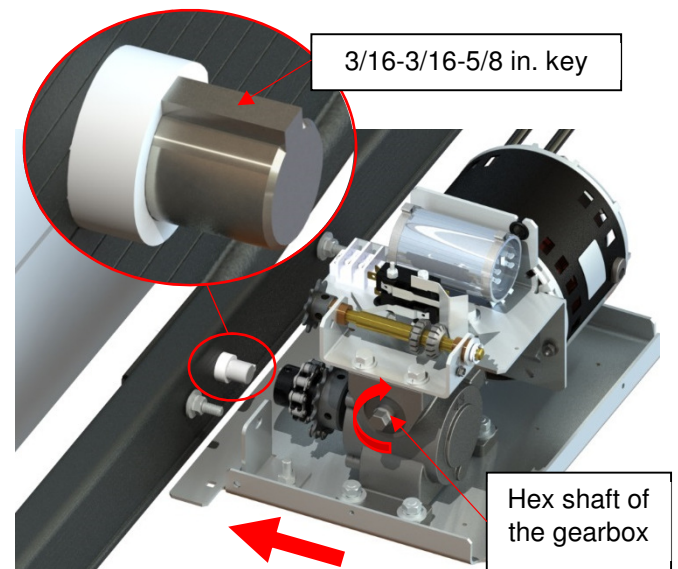

Figure 85

- 21) Once the operator is properly secured, remove the jack lock screws from the posts and put them in the extra holes on top of the posts as shown in Figure 85.

⚠ CAUTION

- ◆ Never remove the jack lock screw if the operator is not completely installed.

⚠ WARNING

- ◆ Ensure to remove the jack lock screw once the operator is secured. Failure to remove the jack lock screw will damage the lifting mechanism.

- 22) Remove the two front 1/4-20-1 in. screws on both sides of the cover as shown in Figure 86. Do not discard these screws.

- 23) Slide the cover approx. 4 in. (10.16 cm) toward the rear of the spa. (Figure 87)

- 24) Ensure the two back 1/4-20-1 in. screws on both sides of the cover are loose but **DO NOT** remove them. Leave a 1/2 in. (12.7 mm) gap between the screws' heads and the C-channel.

⚠ CAUTION

- ◆ Never unscrew the four screws of the cover at the same time (Figure 86 and Figure 87). We highly recommend leaving the two rear screws in and sliding them into the pivot arms' screw slots since the two front screws will be easier to put back.

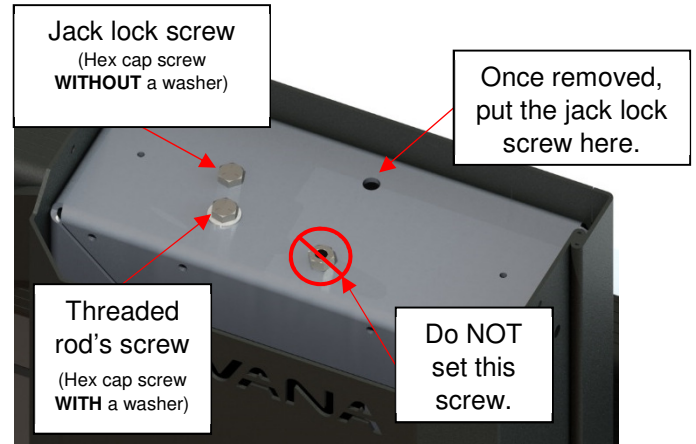

Figure 86

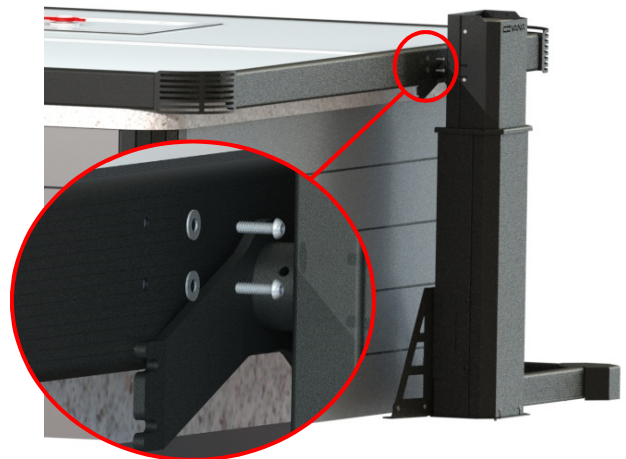

Figure 87

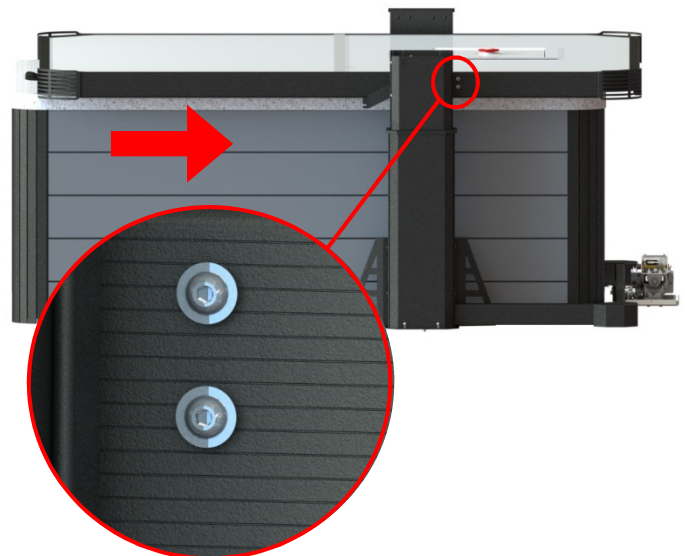

Figure 88

- 25) Use the threaded rod screws (Figure 85) on both posts to align the pivot arms' screw slots with the screw on the cover. Raise the post by turning the threaded rod screw counter clockwise and lower the post by turning the threaded rod screw clockwise. (Figure 88)

⚠ CAUTION

- ◆ The maximum height that can be gained with the threaded rod is 14 in. (35.5 cm). Do NOT unscrew the threaded more than this value. Failure to follow this instruction will damage the posts.

- 26) Tighten the two back 1/4-20-1 in. screws on both sides of the cover. (Figure 88)
- 27) Screw the two front 1/4-20-1 in. button head screws and 1/4 in. flat washers on the cover and pivot arms as shown in Figure 89.
- 28) Fasten the top plates at the top of each post using #8-1/2 in. painted screws. (Figure 90)
- 29) For both posts, slide the all-weather seals down. Ensure they are properly seated on the outer sleeves' base. Push down on the seal as shown. (Figure 91)

Note: The black seal flap of the all-weather seal should be facing downwards when pushing down.

⚠ WARNING

- ◆ Improper installation of the all-weather seal could result in unwanted performance and reduce the lifespan of the mechanical lifting components.
- ◆ Improper installation of the all-weather seal might cause damage to the lifting mechanism.

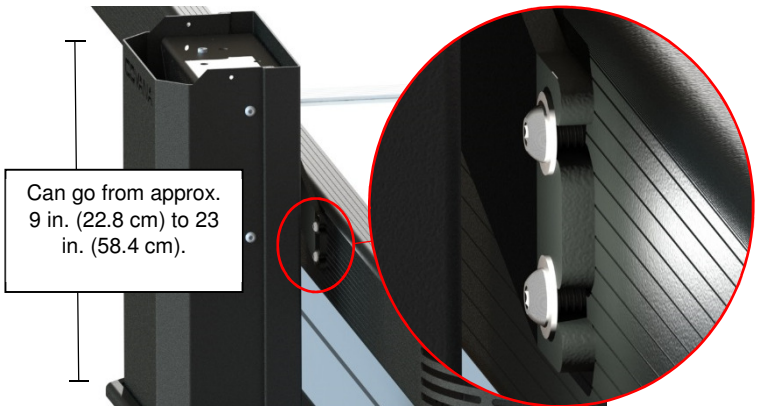

Figure 89

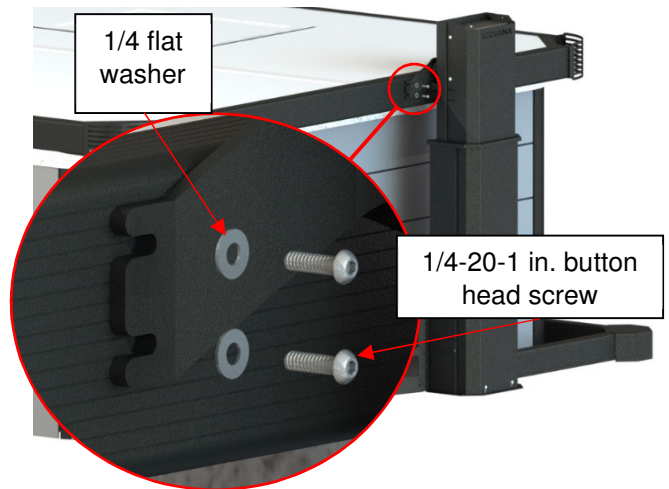

Figure 90

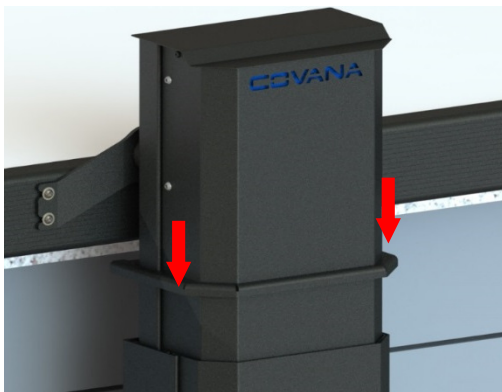

Figure 92

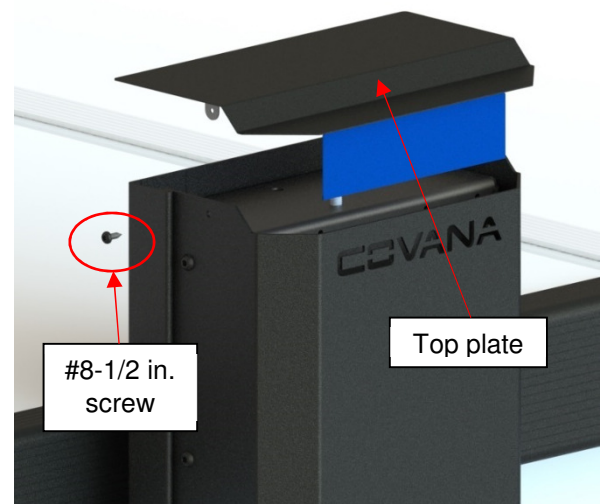

Figure 91

Tub mounting

Note: If the optional ground anchoring brackets are supplied, skip to next section.

- 1) Ensure the system is well positioned around the hot tub and the cover is lying flat and centred on the tub.

⚠ CAUTION

- ◆ It is important to verify that the assembly is well centred and positioned before mounting it. Failure to follow this instruction will cause permanent damage to the tub.

Note: Depending on the size of the hot tub, short, long or both arms might be needed to mount the Horizon to the tub. The angle at which these arms will be fastened also depends on the size of the spa.

- 2) Depending on the height and the size of the hot tub, fasten the needed arms (either short or long arms) to the sleeve brackets using 1/4-20-5/8 in. carriage bolts, 1/4-20 hex nuts and 1/4 lock washers. Keep these loose for now. (Figure 92)
- 3) If the tub is still not reached, add the other arms (either short or long arms) and fasten them with 1/4-20-5/8 in. carriage bolts, 1/4 flat washers, 1/4 lock washers and 1/4-20 hex nuts. Keep these loose for now.

Note: Adjust the angle of the arms so the top tub mount supports are as close to the acrylic as possible, but without touching it, and the bottom mount supports are as close to the bottom of the tub as possible.

- 4) Install the tub mount supports on the arms. If it is possible to fasten the tub mount supports to the absolute extremities of the arms, use 1/4-20-5/8 in. carriage bolts, 1/4 lock washers and 1/4-20 hex nuts. If the tub mount supports need to be fastened in the arms' slots, use 1/4-20-5/8 in. carriage bolts, 1/4 flat washers, 1/4 lock washers and 1/4-20 hex nuts. (Figure 93)

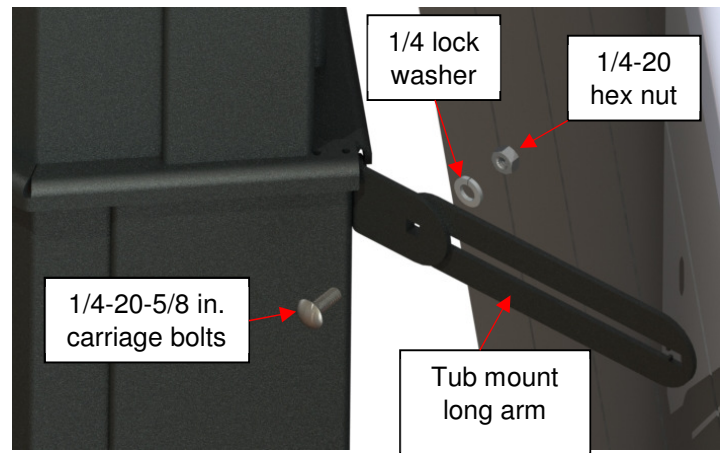

Figure 93

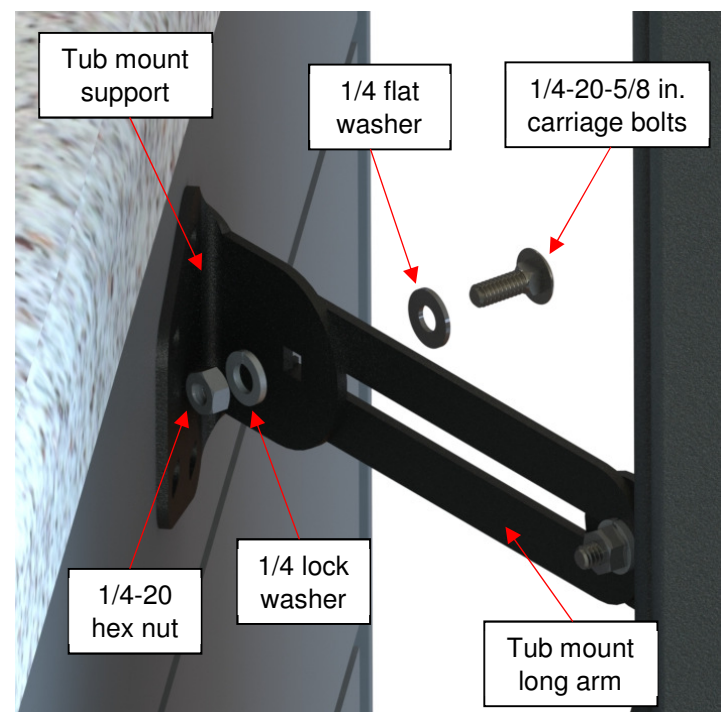

Figure 94

- 5) Tighten all the bolts and ensure the tub mount supports are lying flat on the surface of the tub.

⚠ WARNING

- ◆ Do not overtighten any hardware. Failure to follow this instruction might damage the paint or the hardware itself.
 - ◆ Ensure the arms' angle is satisfying. Failure to follow this instruction will cause permanent damage to the tub.
- 6) Screw the tub mount supports to the tub using four appropriate size screws per tub mount support. (Figure 94)

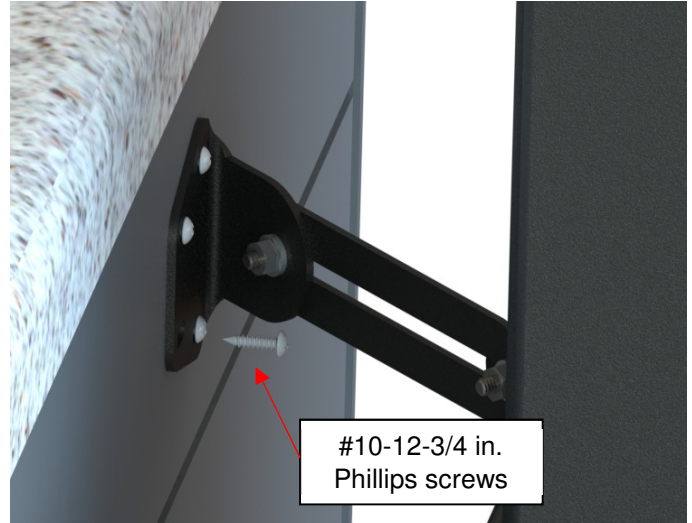

Figure 95

⚠ WARNING

- ◆ Ensure the screws of the tub mount supports are installed on a solid part of the tub's frame.
- 7) Repeat steps 1 to 6 for the other post.
 - 8) Once the Horizon cover is properly mounted to the spa, anchor both corner brackets to the ground using at least 1/4-2 in. screws. (Figure 96)

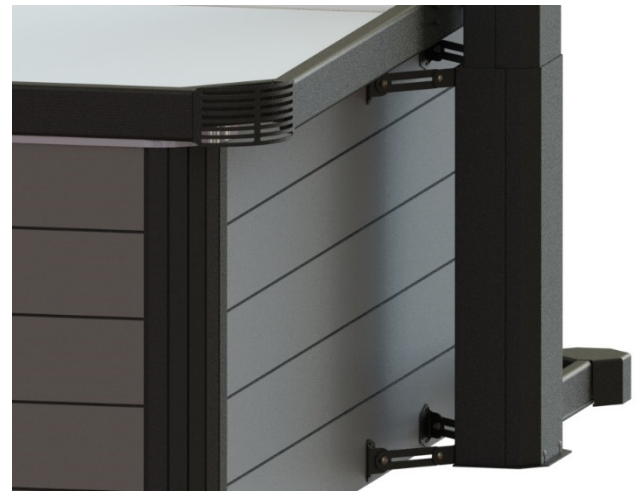

Figure 96

⚠ WARNING

- ◆ The minimum anchoring screw size is 1/4-2 in. Failure to follow this instruction might cause damage to some components or serious injuries.

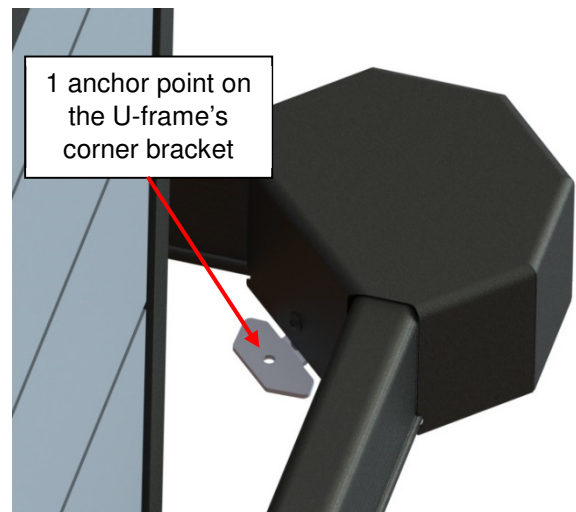

Figure 97

Anchoring the Horizon (optional)

- 1) Ensure the system is well positioned around the spa and the cover is lying flat and centred on the spa.

⚠ CAUTION

- ◆ It is important to verify that the assembly is well centred and positioned before anchoring it. Failure to follow this instruction will cause permanent damage to the deck or the chosen surface.
- 2) Secure the system to the ground with 14 screws (7 on each side).

Note: As shown in Figures 97, 98 and 99, there are two anchor points on each foot plate, four anchor points on the L brackets for each post and one anchor point per U-frames' corner brackets.

⚠ WARNING

- ◆ The minimum anchoring screw size is 1/4-2 in. Failure to follow this instruction might cause damage to some components or serious injuries.

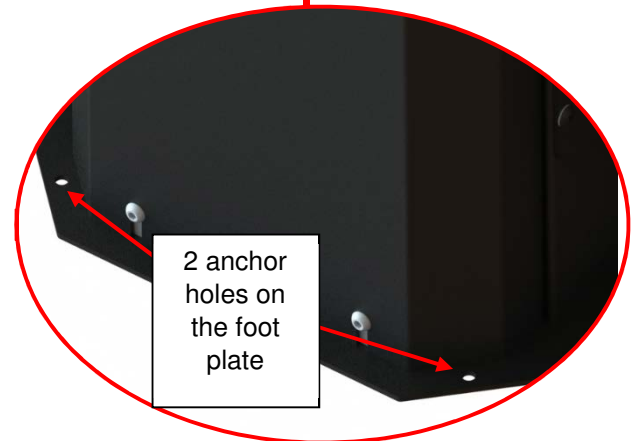

Figure 98

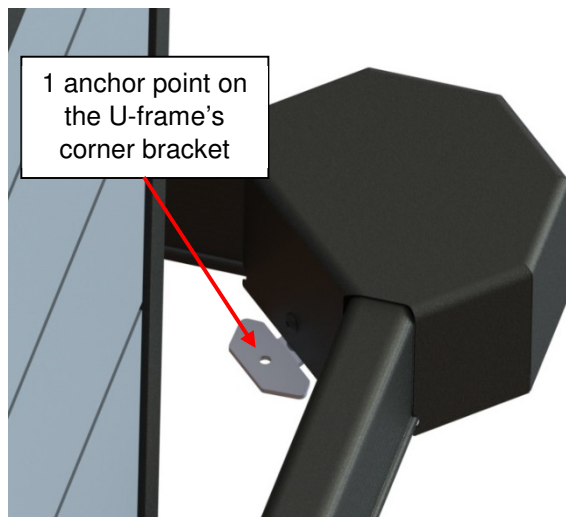

Figure 100

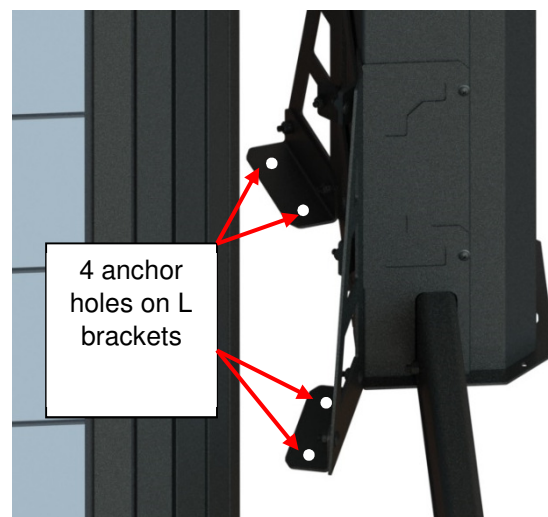

Figure 99

Testing the Horizon cover

- 1) Plug in the Covana cover. **(Have a certified electrician complete the electrical hook-up (see *Electrical hook-up section*) and refer to the *Electrical Diagrams section* in the *Appendix*).**

WARNING

- ♦ All electrical connections must be done by a certified electrician.
- 2) Ensure there is no object directly above the cover or in its lifting path while performing this test. Refer to the instructions in the *Limit Switch Adjustment* section if adjustments are required.
 - 3) Use the key switch to lift it approx. 10 in. (25.4 cm) and stop. Ensure the cover is lifting equally (there are no post higher than the other).

Note: The cover doesn't tilt at this height.

- 4) Lower the cover down completely and ensure the cover is touching the pieces of foam all around the hot tub perimeter.
- 5) Lift the cover all the way up and pay attention for any unusual sounds (metal screeching or knocking). Ensure the cover tilts at approx. 25°. If not, consult the *Troubleshooting section* or contact your Covana local dealer.
- 6) Lower the cover and ensure it stops at the point of contact with all the foam spacers on the hot tub.
- 7) For the *ground anchoring option*, check whether the posts are still level before anchoring. Use the 48" (122 cm) level.

- 8) Both motor side's corner brackets must be anchored to the foundation using the pre-drilled holes. Note that the anchors are not supplied. Use a 1/4 in. (6 mm) concrete anchor for concrete pads or a 1/4 in. (6 mm) lag bolt for wood foundations, and insert a minimum of 1 1/4 in. (30 mm) deep.
- 9) Permanently mount the key switch 5 ft. (1.5 m) away from the hot tub and 5 ft. (1.5 m) above the ground or floor at the key switch location (Figure 29). Furthermore, the key switch terminal should be located in a place where no water down pour or debris could fall. **Cut the power supply when installing the key switch.**

WARNING

- ♦ Failure to permanently install the key switch according to these instructions will void the product certification.
 - ♦ Ensure that the user has a clear view of the Covana cover when operating it. Failure to follow this instruction could cause serious injuries.
 - ♦ Ensure that the base of the Covana cover is not in a flood zone. Any damage caused by flooding or water accumulation will not be covered under the warranty.
 - ♦ Do not place the key switch in an area prone to snow accumulation or water runoff.
- 10) Go to the next section to continue the Horizon cover installation.

Wiper brackets installation

Lift the cover halfway up to proceed to the next steps. The next steps are important for minimizing water intrusion.

⚠ CAUTION

- ◆ Ensure the I-beams are dry and clean.
- ◆ Ensure ambient temperature is between 70°F to 100°F (21 °C to 38 °C) for the ideal application temperature.

- 1) Locate the two wiper brackets that are provided in the boxes. (Figure 100)
- 2) Peel back siding of the double-sided tape of one wiper bracket. (Figure 100)
- 3) Under the cover locate the I-beam and orient the wide flap of the wiper bracket outwards of cover. (Figure 101)
- 4) Stick the wiper bracket on the middle of the I-beam by holding it in place with pressure for at least 60 seconds. This ensures a proper bond to the I-beam. **Ensure to place the wiper bracket flap at the edge of the I-beam directly into the gap between the I-beam and the C-channel.** (Figure 102)

⚠ WARNING

- ◆ Failure to properly install the wiper bracket impedes performance
 - ◆ Failure to install each wiper bracket properly can result in excessive cover leakage.
- 5) Repeat steps 1 to 4 for the other side of the I-beam.

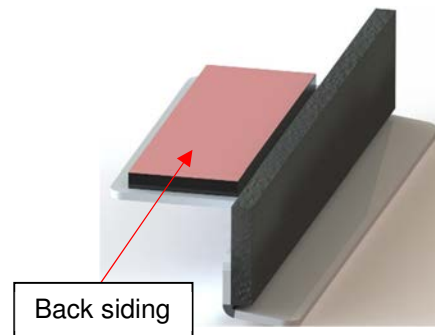

Figure 101

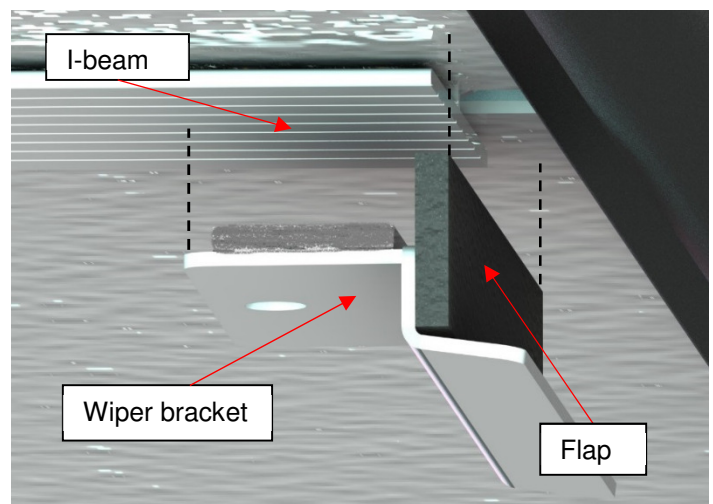

Figure 102

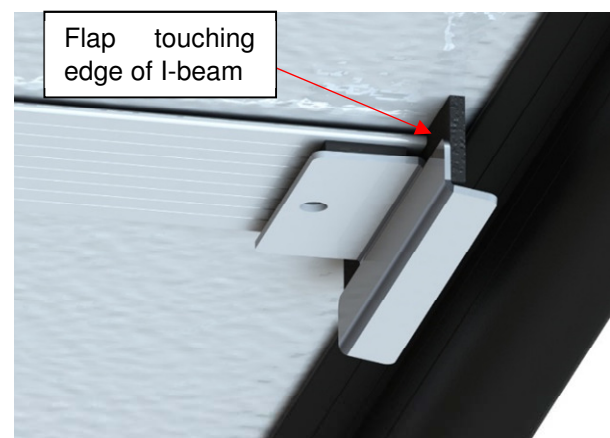

Figure 103

Seal application

- 1) Once the Horizon cover has been fully assembled, raise the cover until the tilt starts and remove the foam spacers and tape. Lower the cover and walk around the entire perimeter of the hot tub, observing where the cover will make contact with the hot tub. This will determine the best location to apply the seal.
- 2) Dry the hot tub edge and the underside of the cover with a clean cloth. Wait until it is dry.

⚠ CAUTION

- ◆ Remove all dirt, oil and moisture for proper seal adhesion. Mild detergent can be used to help clean the surface.
- 3) Apply the provided masking tape around the hot tub where the seal will be installed. The masking tape will ensure the seal is straight when pulled from one corner to another. The ideal location for the seal is closer to the spa's interior edge (Figure 103). The minimum turn radius is 4 in. (10 cm)

⚠ WARNING

- ◆ The use of masking tape is recommended since it will protect the acrylic tub from the clips' glue. Furthermore, pulling the masking tape to the next corner before adhering it will ensure straightness.
- 4) Apply the provided seal clips parallel on the masking tape around the hot tub and be sure to put more in the corners and on any tight turns, filters, etc., keeping in mind that a limited number of clips are provided. (Figure 103)
 - 5) Start installing the seal joint at the side opposite the entrance of the tub (halfway in a clip), with the adhesive layer facing up toward the cover. (Figure 104 and Figure 105)
 - 6) When the seal is installed around the entire hot tub, you must cut the extra length as straight as possible for the best joint finishing results.

⚠ CAUTION

- ◆ Do not install the seal joint near a control system or critical components of the spa.

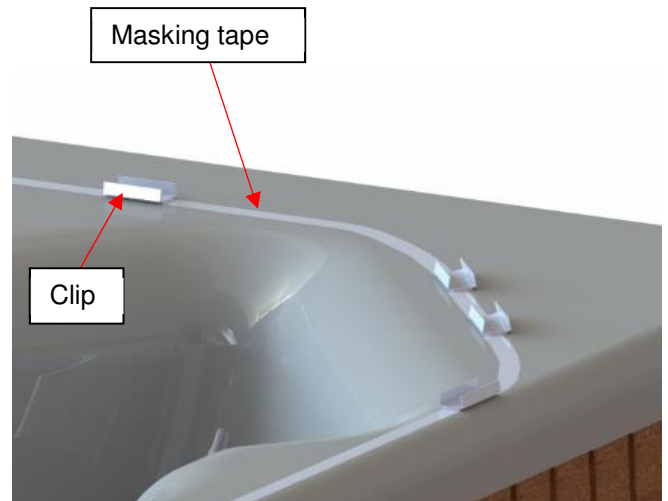

Figure 104



Figure 105

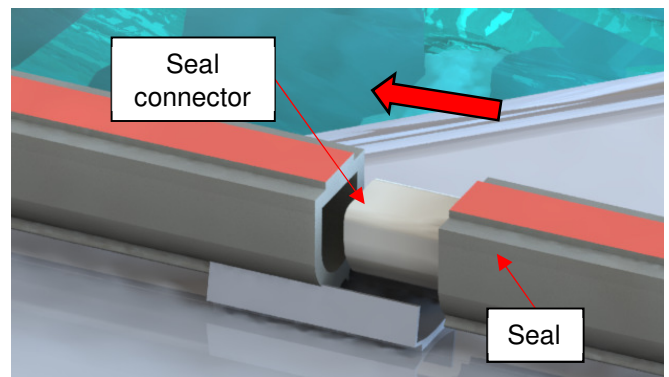

Figure 106

- 7) Use the supplied seal connector and insert it in both ends of the seal. The use of masking tape to hold the two ends is recommended. (Figure 105)

⚠ WARNING

- ♦ At this point, if the ambient air temperature is below 32°F (0°C), a temporary heater must be placed inside the hot tub for 10 to 15 minutes. Once the heater is in the hot tub, lower the cover until it touches the seal in order to increase the air temperature. After 10 to 15 minutes, remove the heater and continue with the seal installation. The rubber seal should not be overheated; the maximum temperature it can withstand is 150°C (302°F). Do not directly heat the acrylic and seal, as this may cause permanent damage. Example, do not place the heater too close to the acrylic surface, as the surface could melt or catch fire. Place the heater on a pedestal or spacers to avoid directly placing it on the acrylic tub.
- 8) Test the seal placement by lowering the cover 1/4 in. (6 mm) over the seal to ensure that the entire perimeter **will make contact** with the seal. If you are satisfied, raise the cover and remove the red plastic backing off the seal.

⚠ CAUTION

- ♦ Ensure the underside of the cover is completely dry before adhering the seal.
 - ♦ Make sure the seal stays tightly in the clips to ensure its proper positioning.
- 9) Lower the cover onto the seal. Leave the cover in this position for **at least 5 minutes** to ensure proper seal-to-cover adhesion.

⚠ WARNING

- ♦ At least **5 minutes** is necessary to ensure proper adhesion of the seal at 70°F (21°C). Less than **5 minutes** could cause the seal to release after a short period of time.

- 10) Raise the cover no more than a 1/4 in. (6 mm) and leave the cover here for approx. 10 seconds, as this will allow the seal to slowly and fully release from the seal clips. You can also use a non-abrasive plastic tool or your fingers to help release the seal.

- 11) Once satisfied that the seal is released, raise the cover until the tilt starts. Apply pressure on the seal to properly bond the adhesive to the underside. To apply pressure to the seal, simply push it against the Horizon cover with your hands.

- 12) Remove the seal clips and tape from the hot tub's edge.

- 13) Lower the Covana cover completely and leave it there for **at least another five minutes**. This will ensure the seal is properly bonded.

⚠ WARNING

- ♦ At least **5 minutes** is necessary to ensure proper adhesion of the seal at 70°F (21°C). Less than **5 minutes** could cause the seal to release after a short period of time

- 14) Raise the cover again at about 6 in. (15 cm) and stop.

- 15) Ensure the cover is flat and that there are no posts higher than the others.

- 16) Lower the cover again, and make sure the seal is touching the hot tub all the way around and there is no steam leaking.

- 17) Lift the cover all the way up and pay attention for any unusual sounds (screeching or knocking). Ensure the cover tilts at approx. 25°. If not, refer to *Troubleshooting* section or call your local dealer.

- 18) Lower the cover completely. The seal installation is done.

The installation process is almost done. There is a checklist for the installer and the customer at the end of this manual. Check the sections to ensure everything has been done properly. It is very important to sign both copies and tear off the installer's copy.

ELECTRICAL HOOK-UP

Avoiding the risk of electrocution

⚠ CAUTION:

- ♦ All electrical work should be carried out by a qualified electrician; otherwise, the certification and warranty will be voided. Furthermore, any modifications to the electrical components will also void the warranty.

⚠ ELECTRICAL DANGER

- ♦ Failure to comply with these instructions may result in death by electrocution or serious injury. Disconnect or turn off and secure all power supplies before starting any intervention on the Covana cover.
- ♦ Always have a licensed electrical contractor perform any electrical maintenance or repairs on the Covana cover. The wiring must comply with all applicable local electrical codes and regulations.
- ♦ The Covana operator must be connected to a circuit that is protected by a dedicated GFCI that complies with all applicable local electrical codes and regulations.
- ♦ Install the Covana cover in such a way that drainage directs water away from the electrical components.
- ♦ Do not connect any auxiliary components to the electrical system of the Covana cover unless they have been approved by Covana.
- ♦ Replace electrical components with original components that are provided or approved by Covana. Ask your dealer for replacement parts.

⚠ ELECTRICAL WARNING:

- ♦ To reduce the risk of electric shock, the green-colored terminal or the terminal marked “g,” “gr,” “ground,” “grounding” or with the \equiv symbol that is located inside the supply terminal box or compartment must be connected to the grounding means provided in the electric supply service panel with a continuous copper wire equivalent in size to the circuit conductors supplying the equipment.
- ♦ Two lugs marked “bonding lugs” are provided on the external surface or on the inside of the supply terminal box or compartment. To reduce the risk of electric shock, connect the local common bonding grid in the area of the Covana cover. Use terminals with an insulated or bare copper conductor not smaller than No. 6 AWG (13.30 mm²).

⚠ ELECTRICAL CAUTION:

- ♦ All field-installed metal components, such as rails, ladders, drains or other similar hardware, within 10 ft. (3 m) of the hot tub must be bonded to the equipment grounding bus with copper conductors not smaller than No. 6 AWG (13.30 mm²).

Grounding and power supply connection

- 1) Remove the four screws on the bottom side of the Covana operator and remove the cover. (Figure 106)
- 2) Refer to the complete wiring diagrams for the European model and North American model in the appendix.

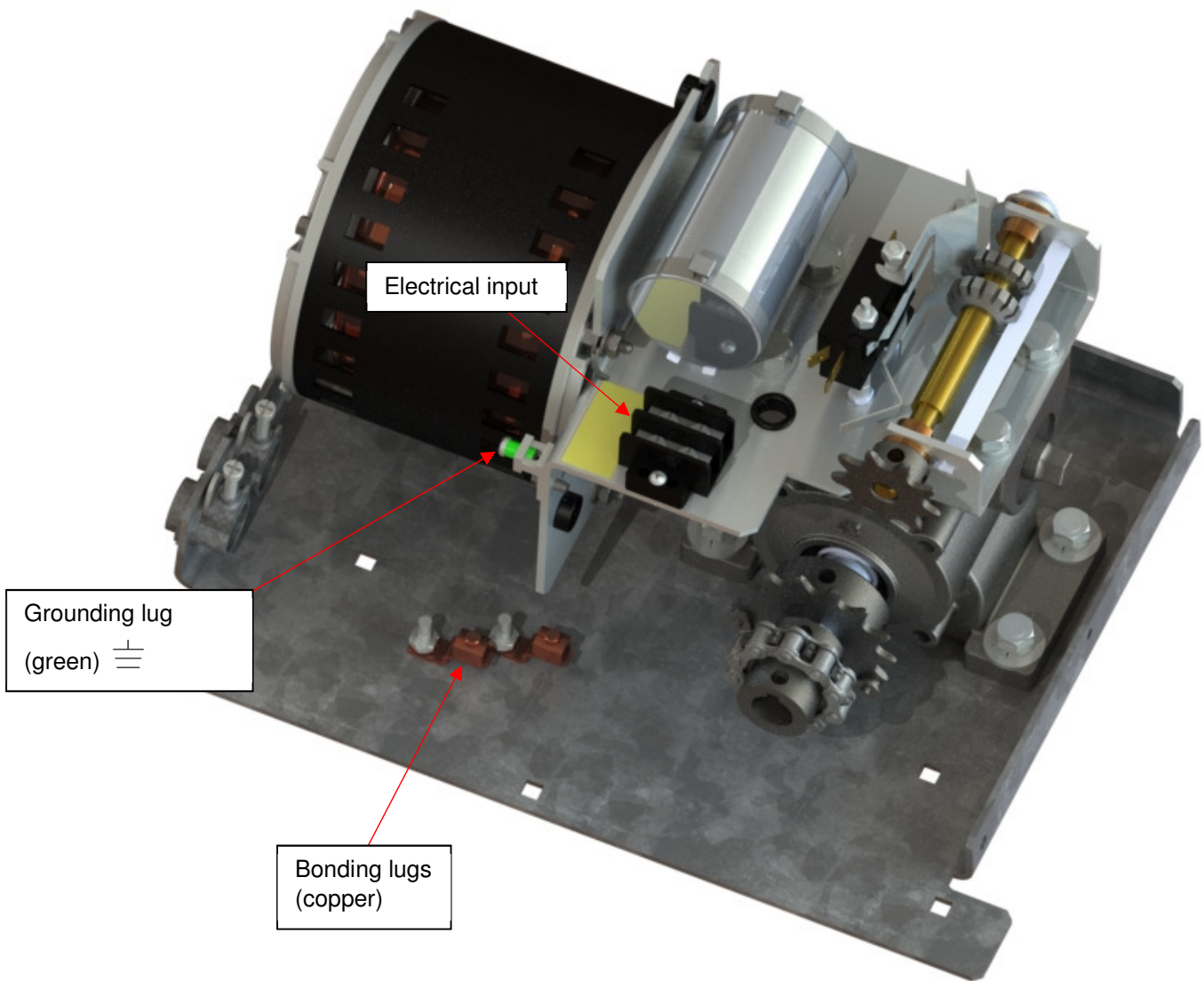

Figure 107

TECHNICAL SPECIFICATIONS

Side elevation dimensions

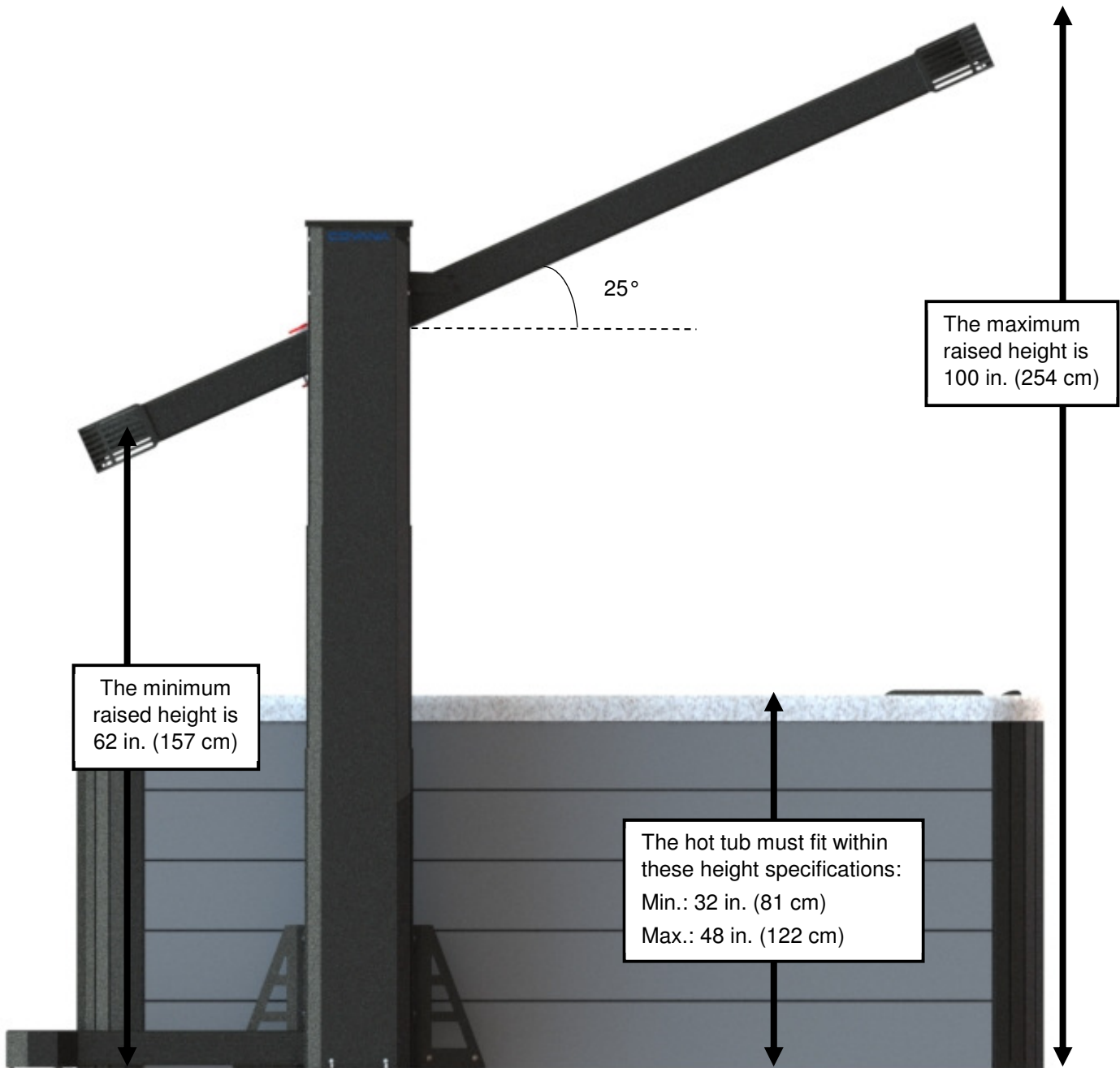

Figure 108

Frame dimensions and footprint

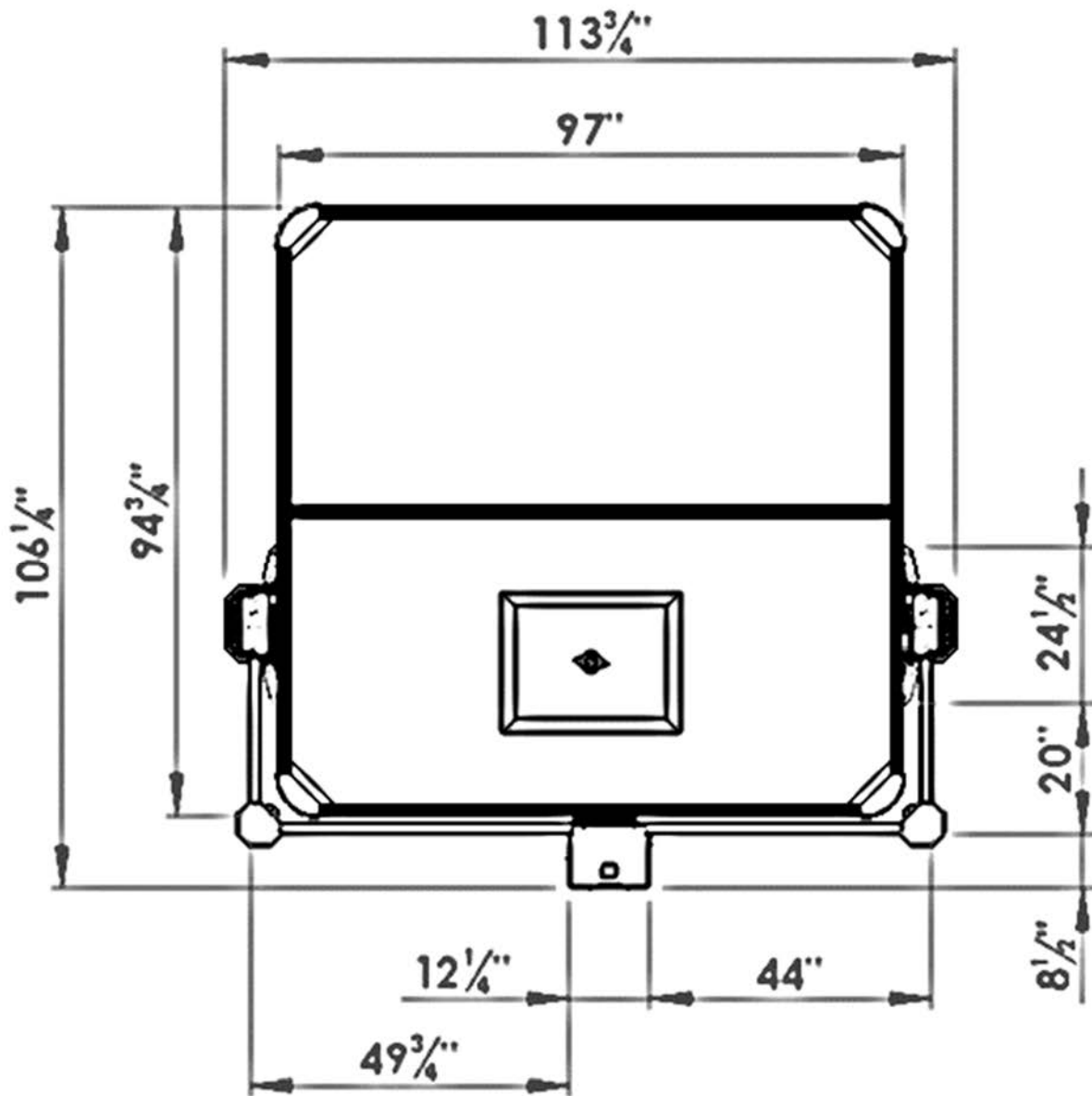

Figure 109

Electrical specifications

- ♦ The Covana cover requires a dedicated single-phase 115 VAC (North America) or 220 VAC (European) hard-wired power supply.
- ♦ The Covana cover must be installed in accordance with and comply with all the applicable local codes and regulations. All wiring and connections should be performed by a qualified electrician.
- ♦ Wires and conduits should be sized according to the local codes and regulations.

North American requirements:

Voltage	115 V, 60 Hz (1 hot, 1 neutral, 1 ground)
GFCI	15 A single-pole GFCI (not included)
Current draw	Max. 12 A

European requirements:

Voltage	220 V, 50 Hz (1 hot, 1 neutral, 1 ground)
GFCI	10 A single-pole GFCI (not included)
Current draw	Max 6 A

Operating limitations

⚠ WARNING:

- ♦ The Covana cover should never be used if the following conditions are reached.

Maximum wind	Gusts of 20 mph (30 km/h) while in the raised position and upwards of 45 mph (70 km/h) when completely lowered on the hot tub.
Maximum weight on the cover (evenly distributed)	120 lb. (54 kg)

General specifications

Lifting speed	2.5 in./s (6.35 cm/s)
Total weight	530 lb. (240 kg)
Length key switch cable	25 ft. (7.6 m)

Limit switch adjustment

⚠ ELECTRICAL WARNING:

- ◆ Disconnect or turn off the power supply before starting any work on the Horizon cover. Additionally, all the electrical work should be performed by a qualified electrician.

Note: The up and down limit switches have been factory-adjusted and there should be no need to readjust them. If adjustments are required to ensure the Horizon cover does not come into contact with surrounding obstacles while being raised, the maximum height may be reduced. Never change the factory setting of the down limit nor increase the up limit beyond the factory setting. Failing to do so may result in equipment damage and/or injury.

- 1) Disconnect or turn off the power and lock the power source..
- 2) Remove the four slotted screws at the bottom of the operator cover and remove the cover. (Figure 111)
- 3) Remove the slotted retaining screw and slide the cam plate out from operator frame. (Figure 109) (Be careful not to move the cam wheels.)
- 4) To reduce the amount of travel in the upward direction, turn the up cam wheel counter clockwise viewed from the cam plate as shown. (Figure 110) When turning counter-clockwise, for each cam wheel's lot travel (approx. 4°), the upper cover limit will be reduced by approximately 5/32 in. (4 mm).
- 5) Once the height is set to the desired position, return the cam plate to its original position and ensure that it is properly inserted in the slot of each cam. **Never operate the system without the cam plate and retaining screw.** (Figure 110)
- 6) Reinsert the slotted retaining screw to prevent the cam plate from coming out.
- 7) Reinstall the operator cover.
- 8) Turn the power on and test the system.
- 9) Screw the cover back on using the 4 slotted screws. (Figure 111)

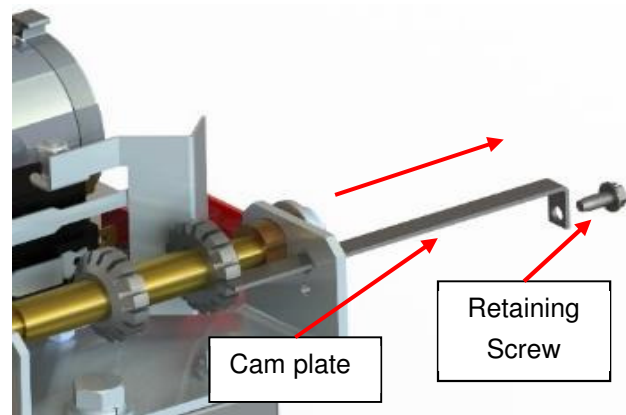

Figure 110

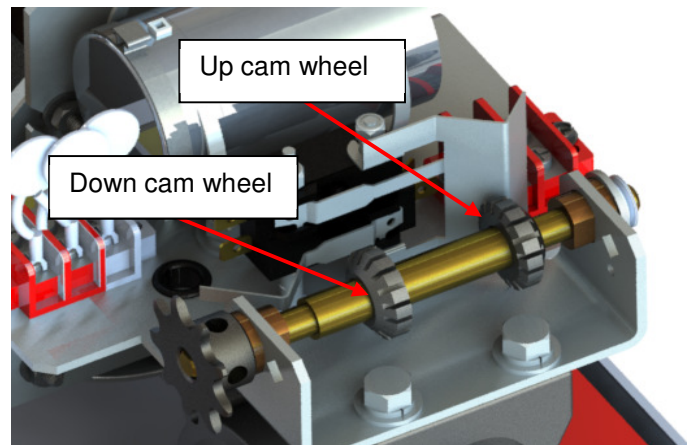

Figure 111

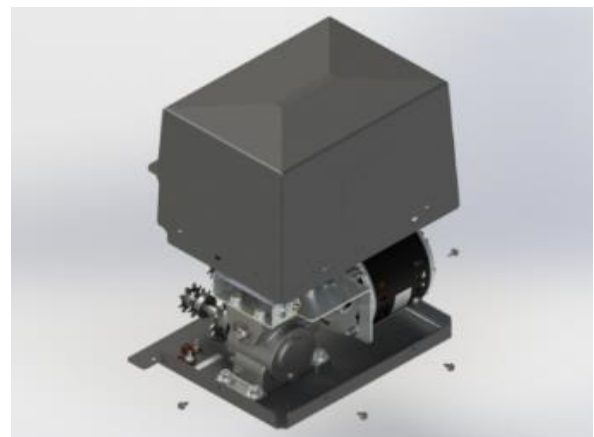

Figure 112

TROUBLESHOOTING

Problem	Probable Causes	Solutions
<p>The Covana cover will not raise or lower. (Silent motor and no movement)</p>	<ul style="list-style-type: none"> ◆ The GFCI is tripped. ◆ The power source is disconnected. 	<ul style="list-style-type: none"> ◆ Reset the GFCI. ◆ Verify that the power source is enabled. ◆ Disconnect the power source for 60 seconds to reset the Covana operator. ◆ Check the breaker panel. ◆ Review the manual lifting procedure section. ◆ Verify whether the cables were damaged or pinched.
<p>The Covana cover will not raise or lower. (Motor humming and some visible movement)</p>	<ul style="list-style-type: none"> ◆ Posts are frozen. ◆ The motor is obstructed. ◆ Posts are obstructed. ◆ The debris on the cover is too heavy. ◆ Power source is disconnected. 	<ul style="list-style-type: none"> ◆ Remove excessive debris from top of the Covana cover. ◆ Verify whether any posts are obstructed. ◆ Use methanol to free ice buildup on the posts. ◆ Regrease the post assemblies. ◆ Refer to Foundation repair section (page 15 on present manual) to verify the relative position of the four posts. ◆ If all previous attempts failed, contact your local dealer.
<p>The middle sleeve has fallen.</p>	<ul style="list-style-type: none"> ◆ Posts are frozen. ◆ The stopper kit is broken/missing. 	<ul style="list-style-type: none"> ◆ Verify whether the all-weather seal is on the inner post and at proper position. ◆ Check whether the stopper kit is broken/missing. ◆ If all the previous attempts failed, contact your local dealer for the reassembly procedure.
<p>The cover raises unequally.</p>	<ul style="list-style-type: none"> ◆ The chain is broken. ◆ A spring pin is broken. 	<ul style="list-style-type: none"> ◆ Contact your local dealer.

<p>The cover raises but does not lower.</p>	<ul style="list-style-type: none"> ♦ The cam plate is missing. ♦ The key switch is faulty. ♦ Limit switches are faulty. 	<ul style="list-style-type: none"> ♦ Only a <i>certified electrician</i> can open the operator and check for faulty up and down limit switches. ♦ Verify whether there is any corrosion on the terminals. If yes, clean the terminals. ♦ Open the key switch terminal and check for faulty switches. ♦ Verify whether any wires are cut/pinched.
<p>The cover lowers but does not raise.</p>	<ul style="list-style-type: none"> ♦ The cam plate is missing. ♦ The key switch is faulty. ♦ Limit switches are stuck. 	<ul style="list-style-type: none"> ♦ Only a <i>certified electrician</i> can open the operator and check for faulty up and down limit switches. ♦ Verify whether there is any corrosion on the terminals. If yes, clean the terminals. ♦ Open the key switch terminal and check for faulty switches. ♦ Verify whether any wires are cut/pinched.
<p>The contour seal seems contaminated.</p>	<ul style="list-style-type: none"> ♦ The seal has accumulated mold. 	<ul style="list-style-type: none"> ♦ Clean the affected areas with bleach and a soft brush.
<p>Cover no longer tilts</p>	<ul style="list-style-type: none"> ♦ Brass shear pin in tilt mechanism is broken. ♦ Gas spring is weak. ♦ Too much snow on the cover. 	<ul style="list-style-type: none"> ♦ Replace the shear pin; call your local dealer. ♦ Remove snow. ♦ If all previous attempts failed, contact your local dealer.

APPENDIX

Wiring diagram (North America) – 60 Hz, 120 VAC Operator

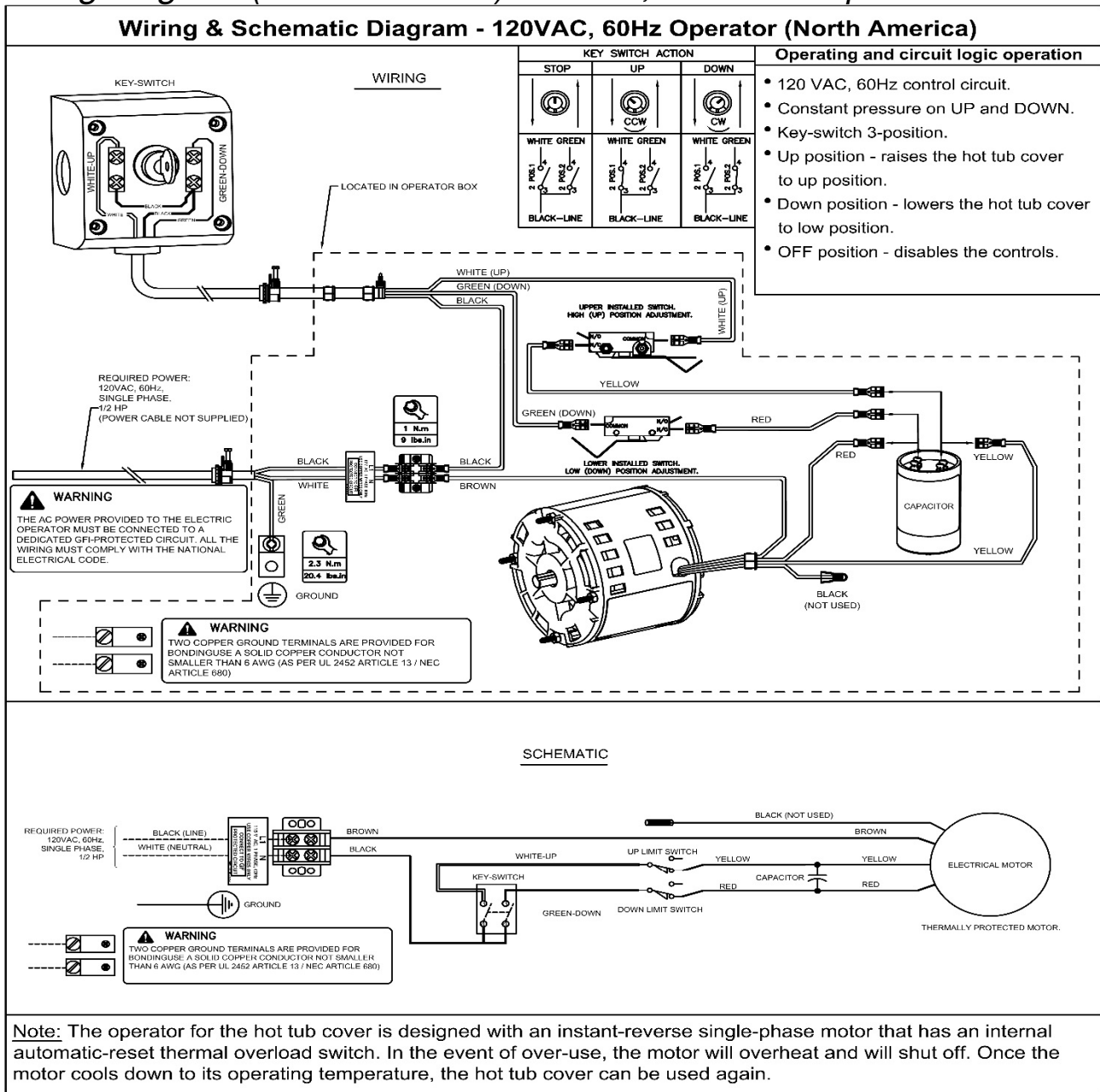

The control circuit operates on 120 VAC, 60 Hz power. Due to the resistance in the wire used to carry the control circuit voltage, it is important to use the appropriate sized wire between the operator and the main power supply. If the wire gauge is not suitable for the distance, the operator will encounter problems, such as motor humming, premature wear of the limit switches' contacts and possible tripping of the motor's thermal protection. All electrical wiring should be installed by a qualified electrician and may vary with respect to conduit size and type as specified in the National Electrical Code (NEC), article 430, allowing for a 5% voltage drop, or comply with any other local codes and regulations. The power source must be connected in accordance with local electrical codes.

Brevet en instance / Patent Pending
www.covana.com

P-2434-3-R5
C.A.: 200826

Wiring diagram (Europe) – 50 Hz, 220 VAC Operator

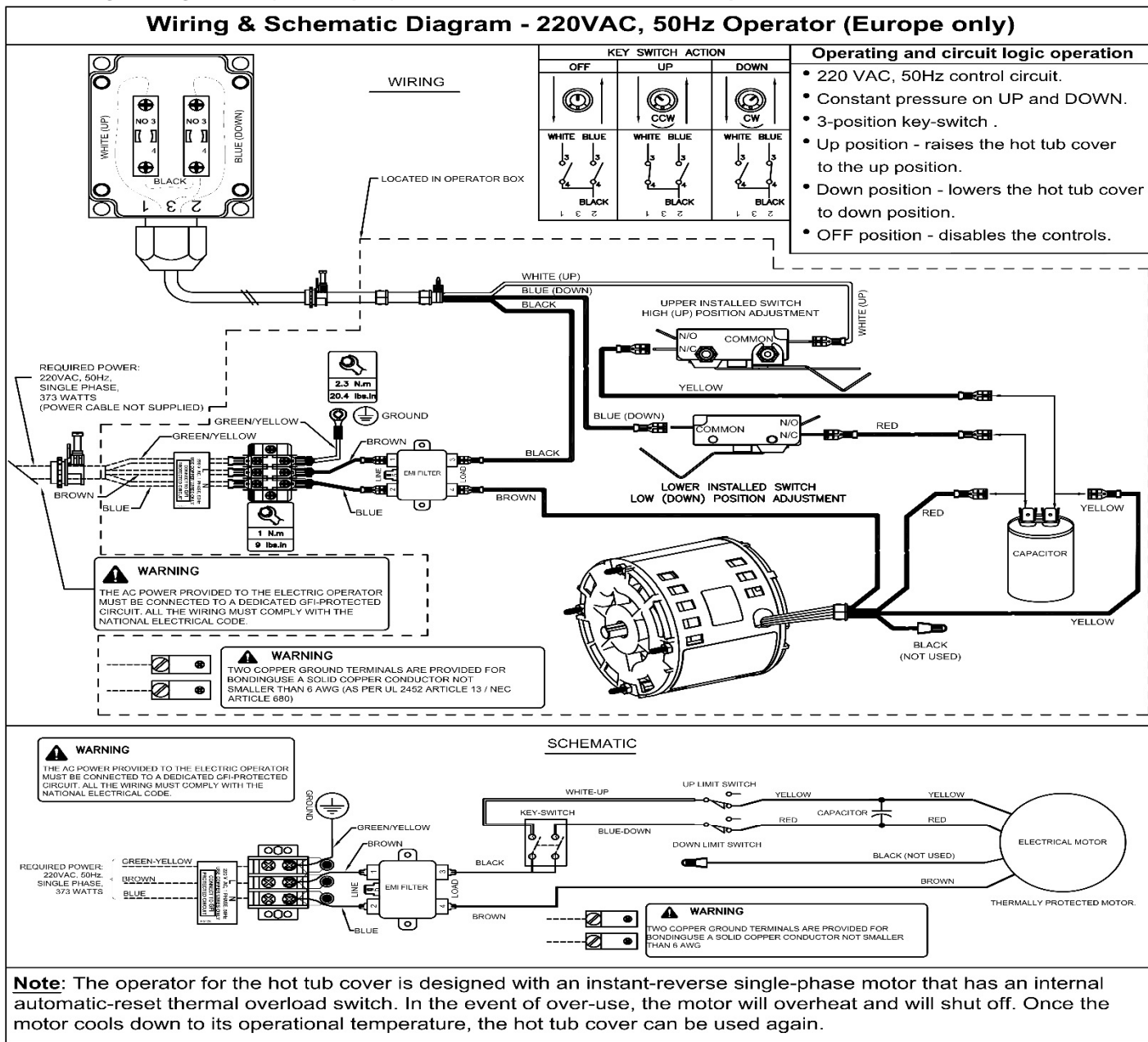

P-24344-R2
C.A.: 200827

INSTALLATION CHECKLIST (Customer copy)

To ensure proper installation, you must carefully read this checklist and verify that you have completed every step of the installation. The customer must receive a completed copy of this checklist.

(Please check each box when verified)

- The base preparation steps have been done correctly. **(Location and foundation preparation sections)**
- The installation steps have been done correctly. **(Uncrating, cover assembly, lifting mechanism and anchoring or tub mounting the Horizon sections)**
- The seal is properly installed and there is no steam leaking out around the cover. **(Seal application section)**
- The wiper brackets are properly installed to ensure the cover is watertight. **(Applying the wiper brackets section)**
- The key switch is **permanently installed** 5 ft. (1.5 m) away from the hot tub and 5 ft. (1.5 m) from the ground.
- The electrical portion of the installation was done by a certified electrician. **(Electrical hook-up, limit switch adjustment sections)**
- All the parts that came with the Covana cover have been installed.
- The start-up procedure was completed. **(The key sequence responds correctly)**
- The all-weather seal functions properly. **(Lay flat against the outer sleeves while fully closed)**

Serial number: _____

Signature of installer: _____

Name of installer: _____

Signature of customer: _____

Name of customer: _____

Date (YYYY/MM/DD): _____

Dealer's name: _____

Owner's address: _____



Contact your dealer for all related service issues.

Made in Canada by Covana, a division of the Canimex group
www.covana.com

PATENTED

CANADA 2,532,429

US 11/162,557

UK 0515168.3

AUSTRALIA 2006200251

The information in this manual was accurate at the time of print. The manufacturer reserves the right to change or improve its product without prior notice.

INSTALLATION CHECKLIST (Installer copy)

To ensure proper installation you must carefully read this checklist and verify that you have completed every step of the installation. The customer must receive a completed copy of this checklist.

(Please check each box when verified)

- The base preparation steps have been done correctly. **(Location and foundation preparation sections)**
- The installation steps have been done correctly. **(Uncrating, cover assembly, lifting mechanism and anchoring or tub mounting the Horizon sections)**
- The seal is properly installed and there is no steam leaking out around the cover. **(Seal application section)**
- The wiper brackets are properly installed to ensure the cover is watertight. **(Applying the wiper brackets section)**
- The key switch is **permanently installed** 5 ft. (1.52 m) away from the tub and 5 ft. (1.52 m) from the ground.
- All the parts that came with the Covana cover have been installed.
- The electrical portion of the installation was done by a certified electrician. **(Electrical hook-up, limit switch adjustment sections)**
- The start-up procedure was completed. **(The key sequence responds correctly and Testing the Covana cover section has been performed)**
- The all-weather seal functions properly. **(Lay flat against the outer sleeves while fully closed)**

Serial number: _____

Signature of installer: _____

Name of installer: _____

Signature of customer: _____

Name of customer: _____

Date (YYYY/MM/DD): _____

Dealer's name: _____

Owner's address: _____