

COVANA

OASIS COVER OWNER'S MANUAL



COVANA

SPA COVER MANUFACTURER

OWNER'S MANUAL



MANUAL NO. 241146

OASIS COVER

MANUAL NO. 241146

First edition 2021-01-01

REVISION	DESCRIPTION	DATE
0	OWNER'S MANUAL NEW RELEASE	2021-01-01
1	WARRANTY UPDATE	2021-12-17

INTRODUCTION	5
CONGRATULATIONS FOR THE PURCHASE OF YOUR NEW COVANA COVER	5
IMPORTANT INFORMATION	6
SAFETY	6
DRUGS AND ALCOHOL	6
IMPORTANT SAFETY INSTRUCTIONS	6
RISK OF ELECTROCUTION	8
ELECTRICAL WARNING	9
MODIFICATIONS TO THE COVER	9
POSITION OF THE KEY SWITCH	10
LABELING	11
RISK OF ELECTROCUTION	11
INFORMATION ON THE ELECTRICAL CABLES	11
KEY SWITCH OPERATION DIAGRAM	12
TECHNICAL SPECIFICATION LABEL	12
NO STEP LABEL	13
AVOID DROWNING LABEL	13
GLOSSARY	14
INSTALLATION PROCEDURE	18
TOOLS REQUIRED	18
PREPARATION FOR THE INSTALLATION	18
DELIVERY	20
SECURE THE PERIMETER	21
UNPACKING PROCEDURE	21
HARDWARE IDENTIFICATION TABLE	27
ASSEMBLY PREPARATION	28
LIFTING MECHANISM INSTALLATION (PART 1)	28
AC LIGHT KIT INSTALLATION	34
LIFTING MECHANISM INSTALLATION (PART 2)	39
TESTING THE COVER	40
NON-PERMANENT MOUNTING PLATE	41
SEAL INSTALLATION	42
ELECTRICAL CONNECTIONS	45
RISK OF ELECTROCUTION	45
ELECTRICAL WARNING	46
LIMIT SWITCH ADJUSTMENT	48
INSTALLATION CHECKLIST (CUSTOMER COPY)	50
INSTALLATION CHECKLIST (INSTALLER COPY)	51
OPERATE THE COVER	53

RAISING/LOWERING THE COVER WITH THE KEY SWITCH	53
LED LIGHT KIT (OPTIONAL)	53
MANUAL OPERATION OF THE COVER	53
WIRE GUARD REASSEMBLY	54
ELECTRICAL DIAGRAMS	55
WIRING DIAGRAM (NORTH AMERICA) – 60 HZ, 120 VAC OPERATOR	56
WIRING DIAGRAM (NORTH AMERICA) (LIGHTS)– 60 HZ, 120 VAC OPERATOR	58
WIRING DIAGRAM (EUROPE) – 50 HZ, 230 VAC OPERATOR	60
WIRING DIAGRAM (EUROPE) (LIGHTS)– 50 HZ, 230 VAC OPERATOR	62
MAINTENANCE	64
WINTERIZING	64
WASHING THE COVER	64
POST GREASING	65
CHAIN LUBRICATION	67
PERIODIC MAINTENANCE TABLE	68
TECHNICAL SPECIFICATIONS	69
COVANA COVER FRONT VIEW	69
FRAME DIMENSIONS AND FOOT PRINT	70
CONCRETE SLAB LAYOUT OPTION	71
ELECTRICAL SPECIFICATIONS	72
TROUBLESHOOTING	74
COVANA LIMITED WARRANTY	77
WARRANTY COVERAGE	77
LIMITATIONS	79
EXCLUSIONS	79
DISCLAIMER AND LEGAL RIGHTS	79

INTRODUCTION

As part of its ongoing commitment to improve the quality, reliability, durability and safety of its products, Covana is proud to present this edition of the cover Owner's Manual.

The various sections that make up this manual will provide you with the most recent information allowing you to understand the operation of the cover, its installation and its maintenance in order to obtain complete satisfaction and to ensure maximum safety and comfort for users.

CONGRATULATIONS FOR THE PURCHASE OF YOUR NEW COVANA COVER

Thank you for choosing our product. The Covana cover you have chosen is the result of excellent engineering, attention to detail and a great deal of pride. With proper care and attention, your cover will last many years and offer great performance.

Although our products are built to last, we strongly recommend that you register your cover at the time of purchase to ensure an adequate follow-up process.

In fact, registering the cover allows us to quickly reach you in the unlikely event a safety notice has to be issued. Your product and safety are a top priority for us at Covana.

You will need your original sales receipt as proof of purchase to obtain warranty service and the work must be performed by a certified technician. If your cover is ever to malfunction, your product registration will allow us to access necessary information in a timely manner.

Experience the benefits of registering your cover at <https://www.covana.com/warranty.html>.

Please take a few minutes to read all the instructions before you use your new cover. This owner's manual indicates how your cover works, how to install it and how to care for it, so you will get the most from your cover for many years.

For service and advice, do not hesitate to call your local authorized Covana dealer.



FIGURE 1: OASIS COVER MODEL

IMPORTANT INFORMATION

Danger, Warning, Caution and Note are used throughout this manual to emphasize important points when necessary:



DANGER

Directs the user's attention to unsafe practices which could result in serious personal injury or death.



WARNING

Directs the user's attention to unsafe practices which could result in serious personal injury or severe damage to the cover.



CAUTION

Directs the user's attention to unsafe practices where personal injury is not likely but damage to cover components could occur.

NOTE

Indicates supplementary information essential to the proper operation of the cover or proper installation or proper maintenance.

The lifespan of your new cover depends on the kind of attention it receives. Pay close attention to the WARNINGS, CAUTIONS, and NOTES.

Read the various notices and instructions attached to the equipment.

Keep this manual in a safe location.

NOTE

Illustrations in this manual are used for reference only and may differ from the actual cover; however, key components addressed in the manual are represented as accurately as possible.

Before reproducing or copying this manual, in whole or in part, written consent must be obtained from Covana. Covana reserves the right to make changes without notice and without incurring any obligation.

SAFETY

The cover was designed, tested and certified to be installed over a residential spa under important installation instructions issued by Covana. Any other type of usage will void the warranty and product certification.

The extra load maximum weight provided in the TECHNICAL SPECIFICATIONS section of this manual is a provision for environmental outcomes, such as a small amount of leftover snow or damp leaves that temporarily accumulate on the cover and evenly distributed on the surface of the cover.

The cover was not designed to support any additional load or people walking or standing on its lid. Failure to observe this instruction will void the cover warranty and nullify its certification.

The power safety cover meets ASTM F1346-91 requirements.

DRUGS AND ALCOHOL



DANGER

The use of drugs or alcohol while operating the cover is strictly prohibited. The impairment of judgment, vision or hearing might affect the safety of other people or result in death.

IMPORTANT SAFETY INSTRUCTIONS



WARNING

KEEP THESE INSTRUCTIONS IN A SAFE LOCATION.

REVIEW THESE INSTRUCTIONS REGULARLY.

NOTE

READ AND FOLLOW ALL INSTRUCTIONS.

**DANGER**

- To reduce the risk of injury, do not allow children under the age of 18 to use this product unless they are supervised at all times.
- Failure to follow all the instructions may result in injury or even death.
- Do not climb or walk on the cover at any time.
- Do not allow children to have access to the cover operation without supervision.
- Never operate the cover until all people and objects are out of the spa.
- Do not operate the cover in extreme wind. See section Technical specifications for the wind limitations.
- The cover must be completely visible when operating the key switch.

**WARNING**

- Be sure to keep the key switch and key out of the reach of children under the age of 18.
- Do not put any type of fabric or plastic sheet, such as a tarpaulin or canvas, on the cover. This may overheat the cover and result in the deformation or delamination of the cover panels.
- Inspect the cover periodically. It should raise smoothly and evenly. Contact your Covana dealer if any unusual mechanical sound is heard during cover operations.

**DOS**

- Remove the key from the key switch after operating the cover. Store the key in a secure location when not in use. Users must bring the key in the spa with them to prevent the unauthorized operation of the cover.
- Never leave the key into the key switch.
- Check the cover frequently for any sign of deterioration.
- Have any repairs, adjustments or mechanical work performed by a certified Covana dealer as soon as possible when you notice any malfunction.
- Completely lower the cover when it is not in use or if the spa is not being monitored.
- The cover should only be operated by an adult.
- This product can be operated by an 8-year-old or older child and persons with reduced physical, sensory or mental capabilities or lack of experience and knowledge **ONLY** if they are supervised by an adult or have received instructions regarding safe use of the cover.
- Children must not play with the product. Cleaning and user maintenance must not be performed by children without supervision.



DON'TS

- Do not operate the unit before all mechanical and electrical connections are completely installed.
- Do not step on or stack anything on the operator cover.
- Do not operate the cover while somebody is in the spa.
- Do not climb, walk, sit or stand on the cover at any time.
- Do not keep the cover open for more than 12 hours. This may cause permanent deformations to the cover.
- Do not converge or directly reflect sunlight on the cover. This could cause permanent damage.
- Do not wash the cover with harsh chemicals or cleaners.
- Do not use a pressure washer to clean any component of the cover. This could result in premature wear or damage.
- Do not use an extension cord to supply electrical power to the cover. The extension cord may not be properly grounded, and the connection is an electrical shock hazard. An extension cord may cause a voltage drop, which may cause the motor to overheat.



CAUTION

- Be sure to follow all instructions in this manual and use only accessories and tools approved by Covana.
- Do not rotate or slide the cover using its edges. This may damage the edge components.
- After removing a component, always keep it in a safe location on a clean and level surface to ensure proper functionality.



CAUTION

- All four jacks of the cover must be properly anchored to the foundation using the anchoring holes of the jack base plate. The optional non-permanent mounting plates can be used when anchoring jacks is not possible, but under strict condition. See [NON-PERMANENT MOUNTING PLATE](#) section for more details.
- This product mainly contains steel, plastic, fiberglass, foam, copper and die-cast aluminum. Please recycle properly according to the local rules.
- The gearbox contains oil and other materials. Please recycle properly according to the local rules.
- The jack stroke is limited by two limit switches. These switches are pre-adjusted at the factory. The down-limit switch should never be readjusted. The up-limit switch should be readjusted only to reduce the maximum height of the cover to avoid possible contact with environment. Please refer to the [LIMIT SWITCH ADJUSTMENT](#) section in this manual before making any adjustments. An improper adjustment can result in damage to the operator and/or to the cover.

RISK OF ELECTROCUTION



CAUTION

All electrical work should be done by a certified electrician, otherwise the certification and warranty will be void. Furthermore, any modifications to the electrical components will also void the warranty.



DANGER

Failure to comply with these instructions may result in death by electrocution or serious injury

**DANGER**

- Disconnect or turn off and secure all power supplies before starting any intervention on the cover.
- A circuit breaker needs to be incorporated into the fixed wiring at the time of installation. This circuit breaker must be accessible to the user or service technician to turn the power off for future maintenance or repair.
- Only a certified electrical contractor may perform any electrical maintenance on the cover. The wiring must comply with all applicable local electrical regulations.
- The operator must be connected to a circuit that is protected by a dedicated ground fault circuit interrupter (GFCI) that complies with all applicable local electrical codes and regulations.
- Install the cover in such a way that drainage directs water away from the electrical and the mechanical components at the base.
- Do not connect any auxiliary components to the electrical system of the cover unless they have been approved by Covana.
- Replace electrical components with original components provided or approved by Covana. Ask your dealer for replacement parts.
- To reduce the risk of electrical shock, replace a damaged electrical cord immediately. Failure to do so may result in death or serious personal injury due to electrocution.
- Do not bury the electrical wires into the ground unless using a direct-burial underground cable. Not respecting this precaution may result in death, or serious personal injury due to electrocution.

**SAVE THESE
INSTRUCTIONS**

ELECTRICAL WARNING**WARNING**

- To reduce the risk of electrical shocks, the green-colored terminal (or the terminal marked “g,” “gr,” “ground,” “grounding” or with a \equiv symbol) that is located inside the supply terminal box or compartment must be connected to the grounding connection provided in the electric supply service panel with a continuous copper wire equivalent in size to the circuit conductors supplying the equipment.
- Two lugs marked “bonding lugs” are provided on the external surface or on the inside of the supply terminal box or compartment. To reduce the risk of electric shock, connect the local common bonding grid in the area of the cover. Use terminals with an insulated or bare copper conductor not smaller than No. 6 AWG (4.11 mm / 13.30mm²).
- All field-installed metal components, such as rails, ladders, drains or other similar hardware, within 10 ft (3 m) of the spa must be bonded to the equipment grounding bus with copper conductors not smaller than No. 6 AWG (4.11 mm / 13.30mm²). (NEC art. 680).

MODIFICATIONS TO THE COVER**WARNING**

- Any modifications to the cover, such as mechanical, electrical or aesthetic, may cause the cover to operate in an unwanted or dangerous way. Furthermore, these modifications are not permitted and might void the warranty and certification.
- The cover has been designed, tested and certified for the only purpose of covering and securing a spa. Any installation that differs partly or entirely from this purpose will void the warranty and certification.

POSITION OF THE KEY SWITCH



WARNING

- The key switch must be permanently installed and located 5 ft (1.5 m) away from the spa and 5 ft (1.5 m) above the deck or ground level, see [Figure 2](#).
- Make sure the user has a clear view of the cover when operating it.
- Furthermore, the key switch must be located in an area where no water downpour or debris might fall on it.

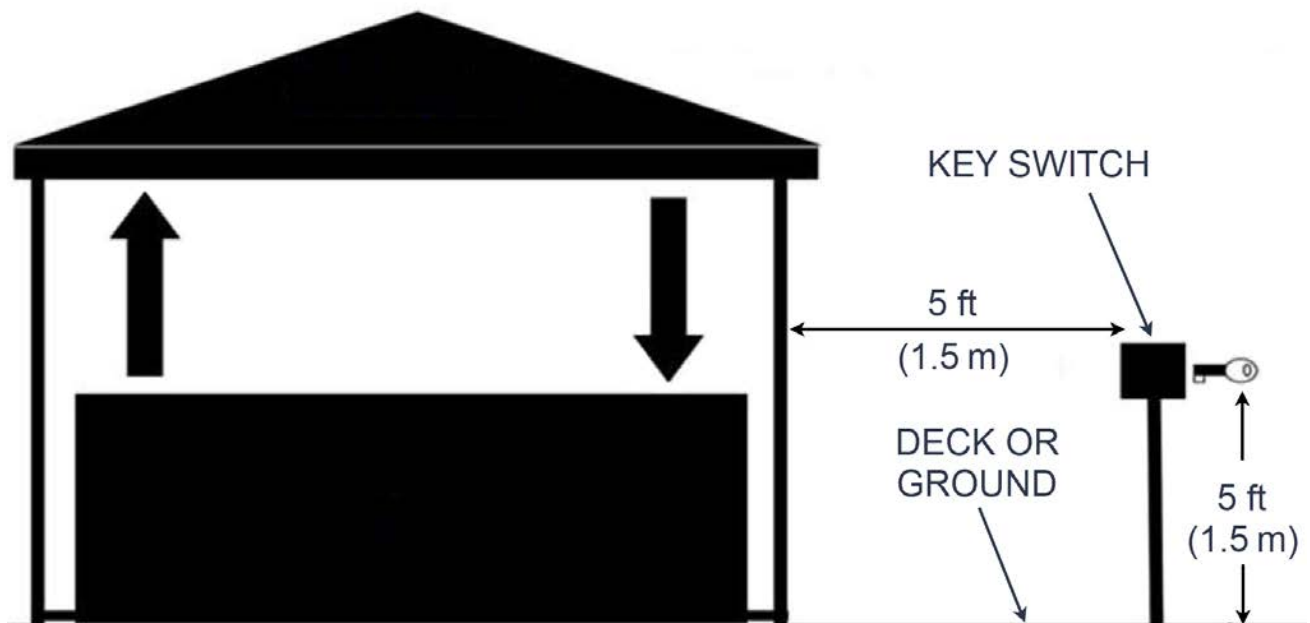



FIGURE 2: POSITION OF THE KEY SWITCH

LABELING

This section shows the location of all safety labels. They are positioned on various components for your safety.

 WARNING
<p>Removing any labels on the cover will void product certification.</p> <p>All labels should always remain visible.</p> <p>It is the owner's responsibility to ensure that these labels are always visible and should never be removed.</p>

RISK OF ELECTROCUTION

This label warns you about the risk of electrocution. It is located on the operator.

 WARNING
<p>RISK OF INJURY DISCONNECT OR TURN OFF ALL POWER SUPPLY BEFORE STARTING INTERVENTION ON THE SPA COVER</p>
 AVERTISSEMENT
<p>RISQUE DE BLESSURE DÉBRANCHER OU COUPER L'ALIMENTATION ÉLECTRIQUE AVANT TOUTE INTERVENTION SUR LE COUVERCLE DE SPA</p>
 ADVERTENCIA
<p>RIESGO DE LESIONES DESCONECTAR O APAGAR LA CORRIENTE ELÉCTRICA ANTES DE COMENZAR A TRABAJAR EN LA CUBIERTA DEL SPA</p>

FIGURE 3: RISK OF ELECTROCUTION

INFORMATION ON THE ELECTRICAL CABLES

These labels inform the user about the danger of electrocution with the presence of water near the electrical wiring.

The labels are located on the power cable near the key switch.









<p>991002 LIRE LE MANUEL D'INSTRUCTION</p>	<p>RIESGO DE LESIONES EN EL AGUA CUBIERTA ESTANDO PROHIBIDO OPERAR</p>
 ATTENTION	 ADVERTENCIA
<p>READ THE INSTRUCTION MANUAL</p>	<p>RISK OF INJURY WHILE IN WATER DO NOT OPERATE</p>
 CAUTION	
 CAUTION	 AVERTISSEMENT
<p>CONNECT ONLY TO A CIRCUIT PROTECTED BY A CLASS A GROUND FAULT CIRCUIT INTERRUPTER</p>	
 ATTENTION	<p>NE PAS ACTIVER EN ÉTANT DANS L'EAU RISQUE DE BLESSURE</p>
<p>CONNECTER UNIQUEMENT À UN CIRCUIT PROTÉGÉ PAR UN DISJONCTEUR DIFFÉRENTIEL DE CLASSE A</p>	<p>730148</p>

FIGURE 4: DANGER WITH WATER

KEY SWITCH OPERATION DIAGRAM

This label shows you how to turn the key into the key switch to lift up or lower the cover.

The label is located on the key switch.

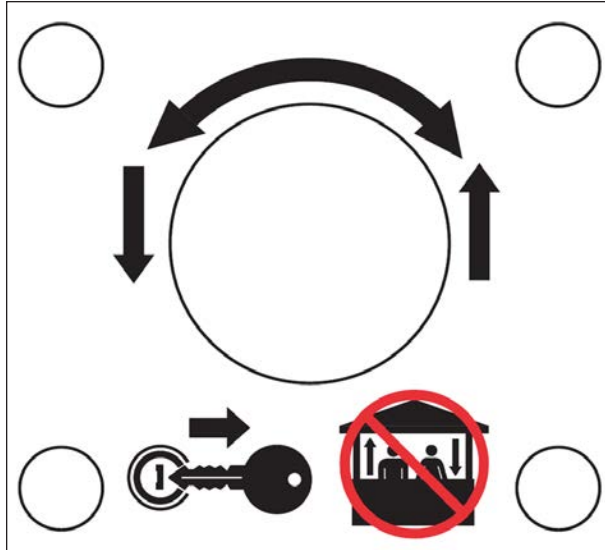

FIGURE 5: KEY SWITCH OPERATION DIAGRAM

TECHNICAL SPECIFICATION LABEL

These labels show you the important technical specifications. They are located on the operator cover.

The European label is used for the units sold in Europe and the North American label is used for the units sold in North America.

NOTE

These labels also show the serial number of the cover.

COVANA a Division of CANIMEX Group		TOLL FREE # 877-278-8010 PATENTED	
MODEL	GHSC	SER.#	YYMMSSSS
WATT	375	VOLTS	230
		PH	1
		AMPS	2.6
CONTROL CIRCUIT (VOLTS)	230	50 Hertz	N·m/ sec
			68
MFG. DATE	YYYY-MMM-DD		Fabrique au Canada Made in Canada
	www.covana.com www.canimex.com		
	DATE OF INSTALLATION:		

FIGURE 6: TECHNICAL SPECIFICATION LABEL FOR EUROPEAN UNITS

COVANA a Division of CANIMEX Group		TOLL FREE # 877-278-8010 PATENTED	
MODEL	GHSC	SER.#	YYMMSSSS
HP	1/2	VOLTS	115
		PH	1
		AMPS	6
CONTROL CIRCUIT (VOLTS)	115	60 Hertz	FT.LB/ SEC
			50
MFG. DATE	YYYY-MMM-DD		Fabrique au Canada Made in Canada
	www.covana.com www.canimex.com		
	DATE OF INSTALLATION:		

FIGURE 7: TECHNICAL SPECIFICATION LABEL FOR NORTH AMERICAN UNITS

NO STEP LABEL

This label is a reminder not to step on this area of the unit.

The label is located on the top of the operator cover.



FIGURE 8: NO STEP LABEL

AVOID DROWNING LABEL

The cover is labeled on four exterior and interior wall faces. If the labels are damaged or no longer meet legibility requirements, please obtain replacement labels by contacting Covana or your local Covana dealer.



FIGURE 9: AVOID DROWNING LABEL

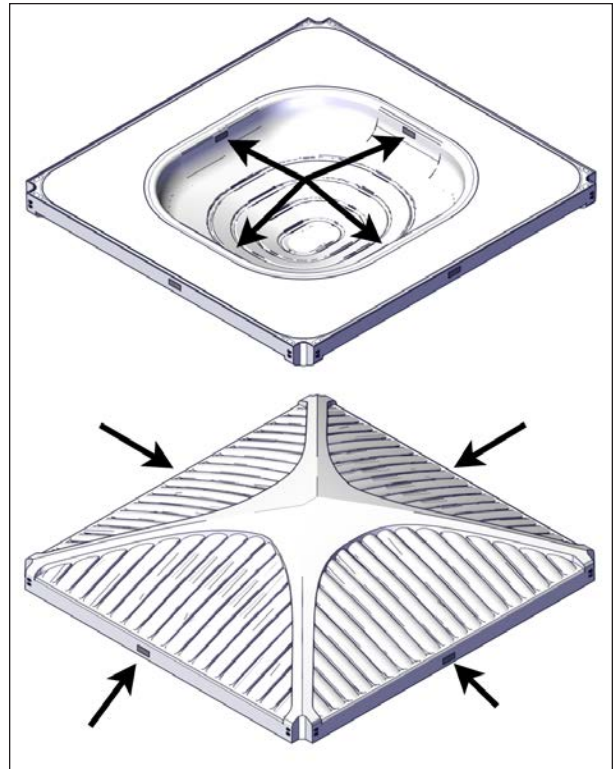
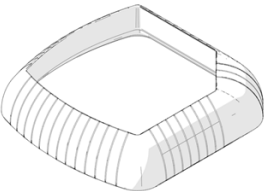



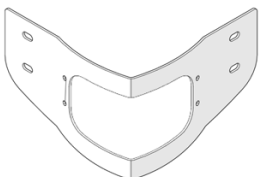
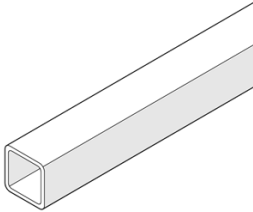
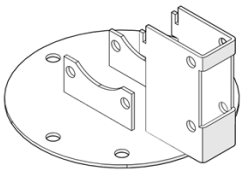
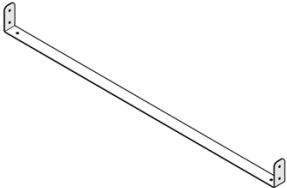
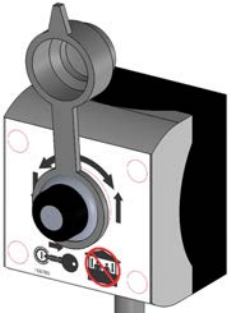

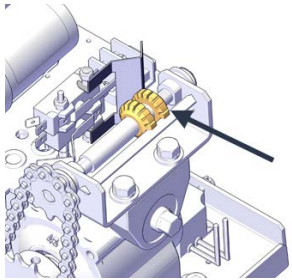
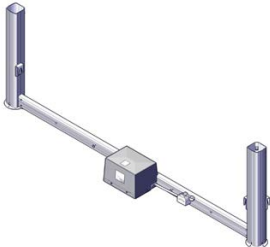

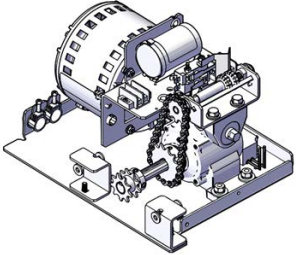

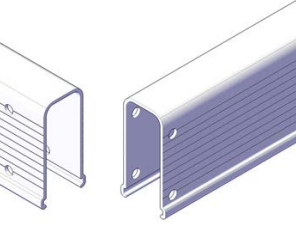
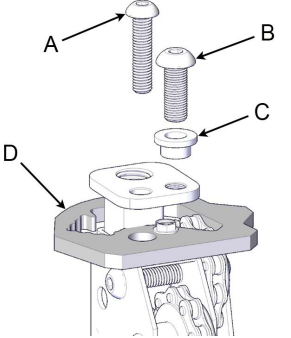



FIGURE 10: LOCATION OF THE AVOID DROWNING LABEL

GLOSSARY

PART	IMAGE	FUNCTION
Sleeve all-weather seal		<p>This all-weather seal protects sleeves from damage due to weather.</p>
Contour seal		<p>The contour seal makes sure there is uniform contact between the cover panels and the spa.</p>
Contour seal installation clip		<p>Contour seal installation clips are used during the installation process to make sure the seal is installed properly.</p>
Contour seal connector		<p>The seal connector is used to link both ends of the contour seal.</p>
Outer corner bracket		<p>The outer corner bracket fastens the cover to the sleeves.</p>
Drive shaft		<p>The drive shaft transmits the power from the operator to the non-motor-side jacks.</p>

PART	IMAGE	FUNCTION
Foot bracket		The foot bracket provides a solid footing of the cover and is attached to the bottom of the jack.
Spa entrance U-frame link		This link is installed under the entrance steps of the spa. It links the two non-motor-side posts.
Key switch		The key switch is used to operate the cover.
Foam spacer		The foam spacer is used for the installation process to protect the spa from direct contact with the cover.
Limit switch		The limit switches are located on the operator. Refer to the LIMIT SWITCH ADJUSTMENT section for further details.
Motor frame		The motor frame is composed of two motor-side jacks and the operator.

PART	IMAGE	FUNCTION
Jack		<p>Jacks are a very important component of the cover. They allow the cover to lift up and down.</p>
Operator		<p>The operator powers and controls the lifting mechanism of the cover.</p>
Sleeve		<p>The sleeves are aluminum extrusions to hide and protect the jacks.</p>
U-frame		<p>The U-frames protect the lifting mechanical components and connect all four posts at the bottom.</p>
Jack lock screw (A)		<p>The jack lock screw (A) prevents the non-motor side jacks from extending. Do not remove this screw until the driving shaft is connected.</p> <p>Follow installation steps carefully.</p> <p>A: Jack lock screw B: Top plate screw C: Bushing D: Alignment bracket (red)</p>

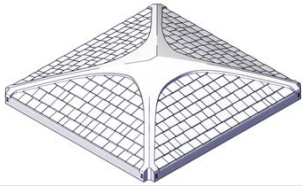
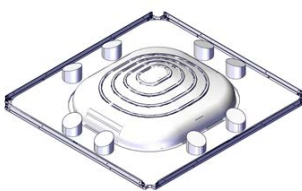
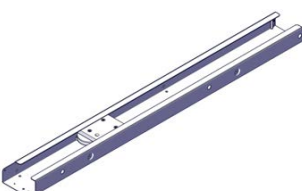
PART	IMAGE	FUNCTION
Wire guard (optional)		<p>The wire guard is an assembly that will house a wire that comes from the cover to light up the LED light kit. It protects the wire from becoming overly taut and will release extra wire if necessary.</p>
Outer shells		<p>The Shingle type outer shell is the outside part of the cover.</p>
		<p>The Darling type outer shell is the outside part of the cover.</p>
Inner shell		<p>The inner shell is the insulating part of the cover.</p>
CTS-70 (Continuous tension system) (optional)		<p>The CTS-70 is located in the roof of the cover. It keeps the wire perfectly taut throughout the cover's up and down cycles.</p>

INSTALLATION PROCEDURE

This section shows the procedure on how to install your new cover on your spa.

It requires two people for certain steps.

Wear the necessary PPE such as protective glasses, boots and gloves.



CAUTION

The cover should be installed by a certified Covana installer. Having the cover installed by someone who is not certified will void the warranty.

Ask your local Covana dealer for information on certified installers.

TOOLS REQUIRED

- Scissors or a utility knife
- Robertson screwdriver
- Slotted screwdriver
- Phillips screwdriver
- Hammer
- 3/8" (10 mm) socket wrench and spanner
- 7/16" (11 mm) socket wrench and spanner
- 1/2" (13 mm) socket wrench and spanner
- 5/32" (4 mm) Drill bit (supplied)
- 7/32" (5.5 mm) Allen key
- 25' (7.62 m) measuring tape
- Rubber mallet
- SAE or metric Socket kit
- 48" (122 cm) level
- Step ladder
- J-Roller with rubber roller

PREPARATION FOR THE INSTALLATION

To ensure safe use of the cover, it must be installed on a properly prepared surface. It is important to adequately prepare the foundation and carefully read the following recommendations.

SPA LOCATION CONSIDERATIONS

Make sure the future cover location is not subject to the water downpours or debris falling.

Make sure the base of the cover is not in a flood zone. Any damage caused by flooding or water accumulation will not be covered by the warranty.

Make sure there are no obstacles, such as branches or electrical power lines, in the operating area of the cover.

Refer to the Technical Specifications section for cover dimensions

Make sure there is safe access to the spa, free of obstacles or debris.

All the base components of the cover must be supported by the foundation.

Do not converge or directly reflect sunlight on the cover. This could cause permanent damage (Example: reflection from a window).

Make sure the cover is installed on a clean surface free of any vegetation, such as grass, branches or roots, or mineral contaminants, such as rocks, dust or sand.

The key switch must be permanently mounted and located 5 ft (1.5 m) away from the spa and 5 ft (1.5 m) above the deck or ground level see [Figure 2](#). This ensures the user has a clear view of the cover when operating it. Furthermore, the key switch terminal should be located in a location where no water downpour or debris could fall on it.



DANGER

Failure to properly install the key switch according to these instructions could result in injury or even death.



WARNING

Failure to permanently install the key switch as indicated could void the warranty and certification. Only proper installation of the key switch combined with the suggested procedures and caution will reduce such risks.

Do not install the cover in an area prone to snow accumulation and water run-off.

FOUNDATION PREPARATION

The cover requires a clean, flat and level surface such as an engineered wood deck or a concrete slab.

Each of the four jacks of the cover must be properly anchored to the foundation using at least one of the holes located on the foot of each post. Use a 1/4" (6 mm) concrete anchor bolt for concrete pads or a 1/4" (6 mm) lag bolt for wood foundations and insert at least 1 1/4" (30 mm) deep (tag bolts and anchor bolts are not included). If you cannot meet these requirements, install a set of non-permanent mounting plates. See [NON-PERMANENT MOUNTING PLATE](#) section for more information.

For an existing foundation, refer to the Technical Specifications section to see the diagram.

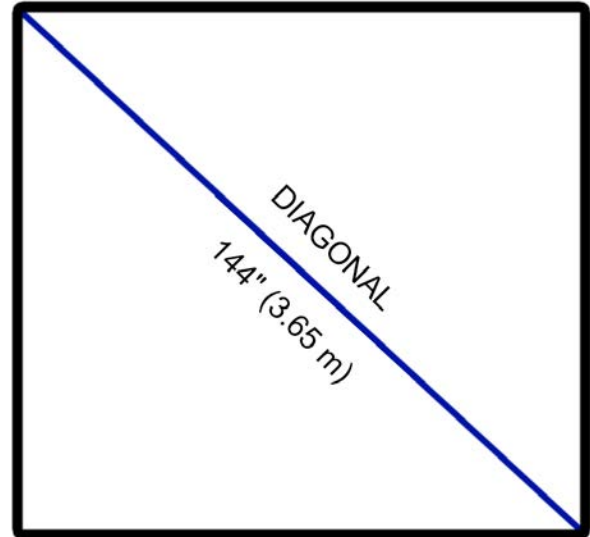

FIGURE 11: FOUNDATION DIAGONAL



WARNING

The non-permanent mounting plates can only be used in areas with low winds (less than 30 mph (50 km/h) in open position and less than 45 mph (70 km/h) in closed position).

The non-permanent mounting plates must also be properly installed.

The cover requires a solid foundation. The foundation for the cover must be able to support at least 600 lb. (272 kg).

The foundation must be leveled with a maximum tolerance of 1" (25 mm) over a diagonal section as shown in [Figure 11](#). Refer to Technical Specifications section for information on the minimum base size of the foot print.

The annual variation in levelness for the same diagonal section cannot exceed 1/4" (6 mm)



CAUTION

Damage caused by inadequate foundation construction is not covered by the Covana warranty. It is the responsibility of the owner to provide a proper foundation.

Failure to follow these guidelines might cause permanent damage or improper functioning of the cover. Such damage might not be covered by the warranty.

DELIVERY

The following steps indicate how to handle the crate to avoid any damage to all components. It also shows how to unpack components.

NOTE

If you find any damage, refer to the Covana Damaged claim form attached to the crate, take pictures and simply refuse the delivery from the carrier.

HANDLING

- The forklift must have a minimal capacity of 5,000 lb. (2,268 kg) at 24" (610 mm) from the fork arm and 96" (2.44 m) length fork see [Figure 12](#).

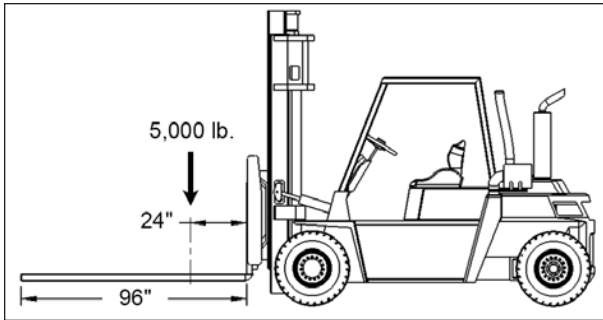

FIGURE 12: FORKLIFT MINIMAL LOAD AT 24"

OR

- A minimal capacity of 5,000 lb. (2,268 kg) at 64" (1.6 m) with 96" (2.44 m) extension forks see [Figure 13](#).

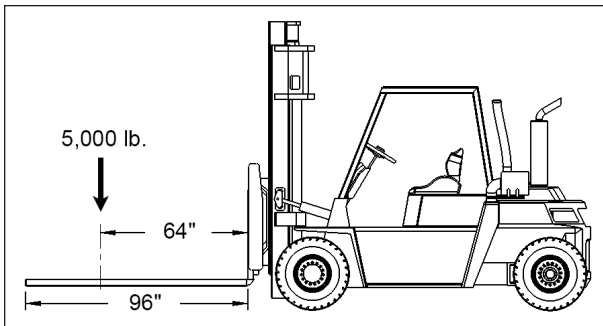

FIGURE 13: FORKLIFT MINIMAL LOAD AT 64"

The overall total grip must be 16" (432 mm) in both previous setups see [Figure 14](#).

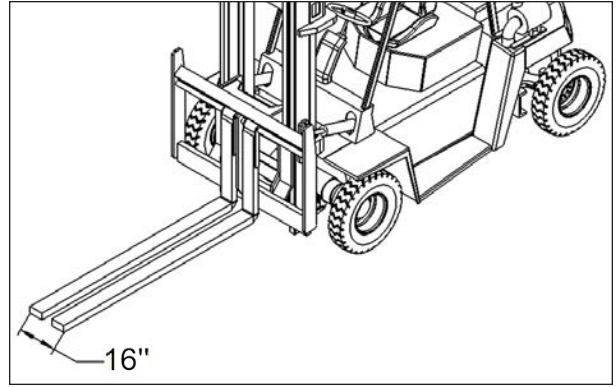

FIGURE 14: FORK OVERALL GRIP

SECURE THE CRATE

Before unloading the components, for security and safety, the crate must be secured to the forklift with ratchet tie down straps or similar tools [Figure 15](#).

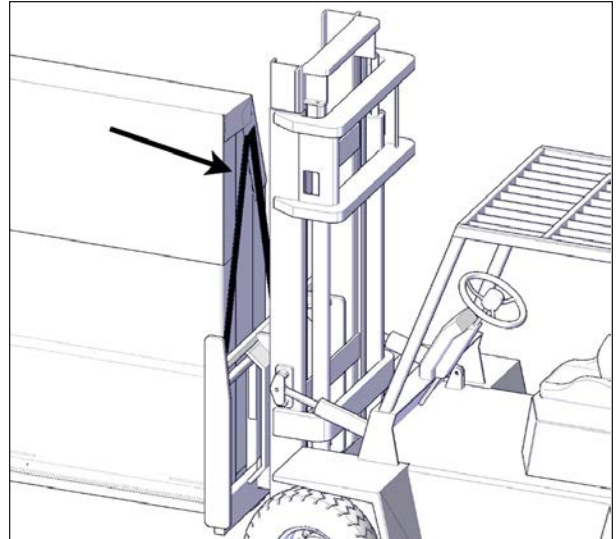

FIGURE 15: STRAPPING GOOD PRACTICE

Do not tie from the top of the crate see [Figure 16](#).

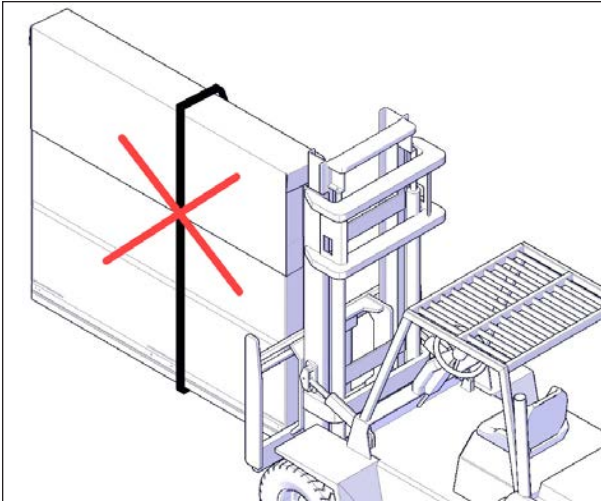

FIGURE 16: DO NOT TIE FROM THE TOP OF THE CRATE

Always make a visual inspection of the condition of the crate before attempting any action with the forklift.

SECURE THE PERIMETER

Before or while handling the crate with the forklift or any other lifting tool, the forks should be fully under the crate before any elevation and should be moved by one of the two short sides indicated on the crate.

No one should be in front, beside or around within 12' (3.6 m) of the crate being handled. The crate should not be kept higher than 6" (152 mm) from the ground at all times to avoid injury to workers and helpers see [Figure 17](#).

Make sure the forklift is stopped and the crate down and stable on the floor before approaching the crate for further handling or unpacking. If the crate seems to be unbalanced, unstable, tilting or wobbly, do not attempt any action in any circumstances to stabilize by hand.

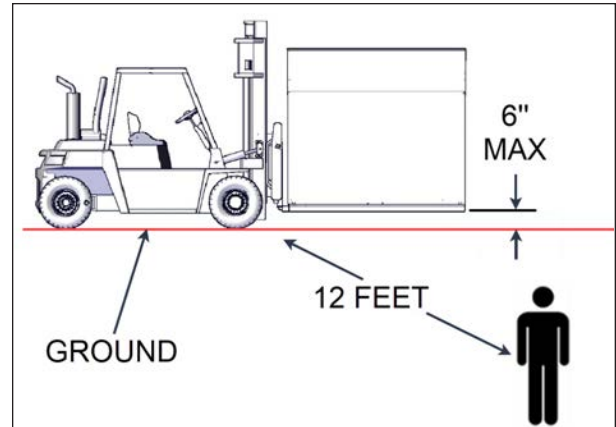

FIGURE 17: SECURE THE PERIMETER

UNPACKING PROCEDURE

1. Before unpacking the unit, make sure there is no visible damage to the crate. In case of any suspicious damage, take pictures first and please call Covana customer service immediately. Always stand the crate in the vertical position. Make sure the wind conditions are safe enough when unpacking the components.
2. Remove both cardboards see [Figure 18](#).

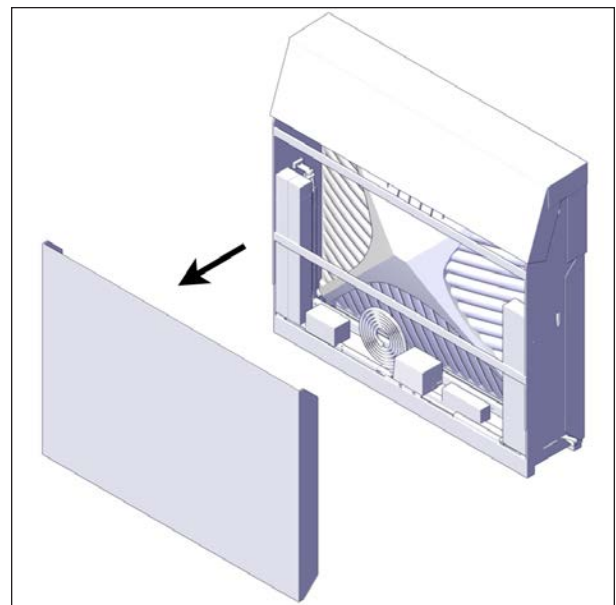

FIGURE 18: REMOVAL OF THE CARDBOARDS

3. Hammer off the wood furring strips by hitting on the inside of the side panels see [Figure 19](#).

CAUTION

Be careful not to damage the cover components and other parts in the crate.

Flatten all protruding nails.

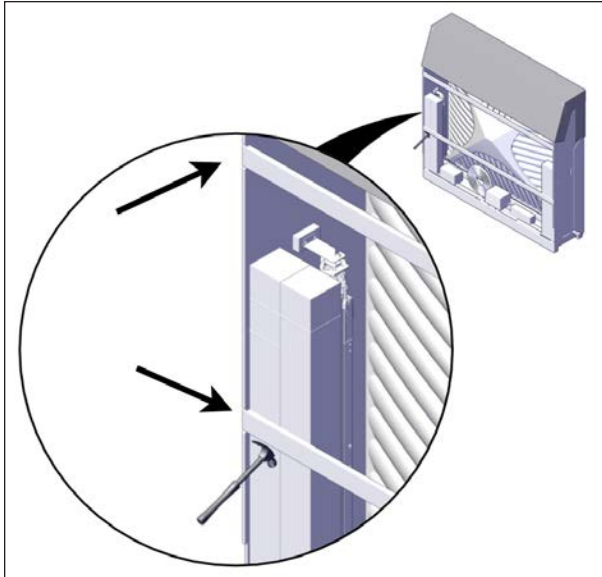

FIGURE 19: REMOVE CARDBOARD AND STRIPS

4. Remove the hardware box, the foam spacers and the seal from the crate. Temporarily put these items in a safe location see [Figure 20](#).
5. Use scissors or a utility knife to cut the four cable ties holding the sleeve boxes (2 boxes per side) and discard the cable ties.

CAUTION

When using the utility knife or scissors, be careful not to puncture the cardboard box.

6. Remove the sleeve boxes (4) from the crate and keep in a safe location see [Figure 20](#).

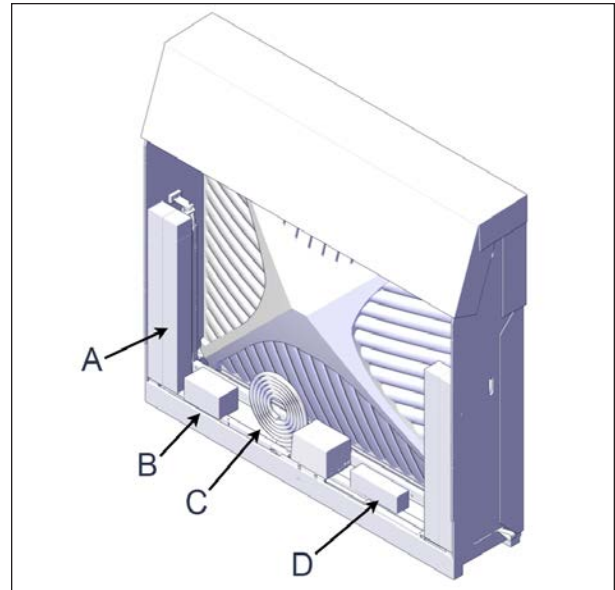

FIGURE 20: REMOVE COMPONENTS FROM CRATE

ID	DESCRIPTION
A	SLEEVE BOXES
B	HARDWARE BOX
C	CONTOUR SEAL
D	FOAM SPACERS

7. Use a flat screwdriver to remove the metal strapping holding the operator in place see [Figure 21](#).

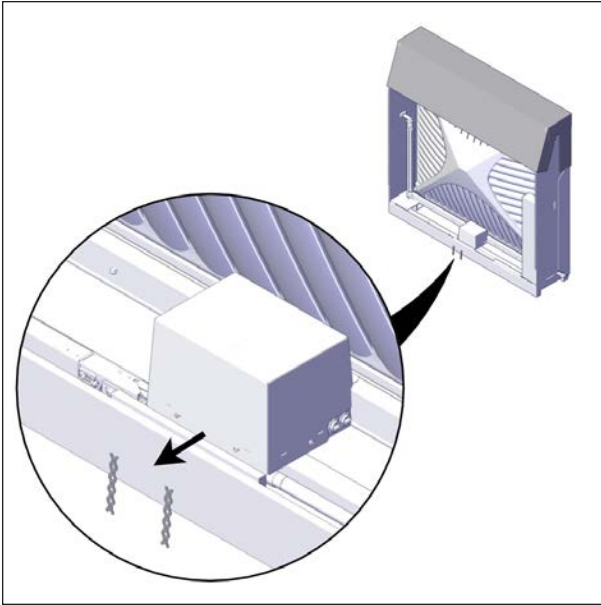

FIGURE 21: MOTOR FRAME ASSEMBLY REMOVAL

8. Reinstall the screws (2) on the operator cover.
9. Use the 3/8" (10 mm) socket wrench to unscrew the hexagonal 1/4" x 2" lag bolts on the bottom of both jacks. There are two lag bolts per jack see [Figure 22](#).

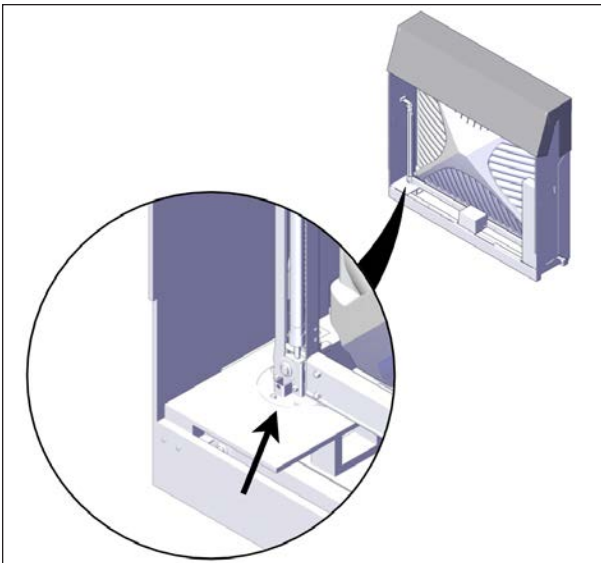

FIGURE 22: REMOVE BOTTOM LAG BOLTS ON JACKS

10. For each jack, use the 7/32" (5.5 mm) Allen key to loosen, but not fully remove, the 3/8" x 1" screw holding the jack to the top bracket see [Figure 23](#). There is one screw per jack. Do not discard this screw and bushing; they are required to assemble the cover.

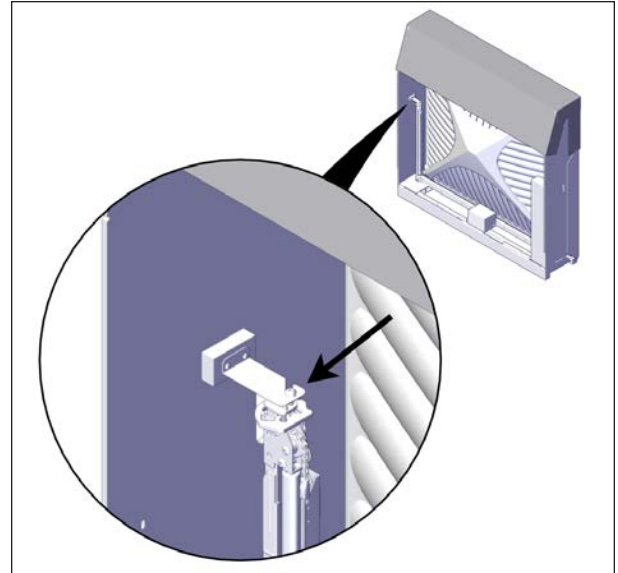

FIGURE 23: LOOSEN TOP SCREW ON JACKS



WARNING

Do not remove the alignment bracket on the top of the jack (red part).

11. With the help of another worker, remove the motor frame assembly from the crate. Position one hand under the horizontal portion of the motor frame and the other hand on the vertical jack see [Figure 24](#). Handle and carry the assembly with care, so that the jacks follow the natural bending of the U-frame. Install the motor frame assembly on a level surface and make sure it will not fall.

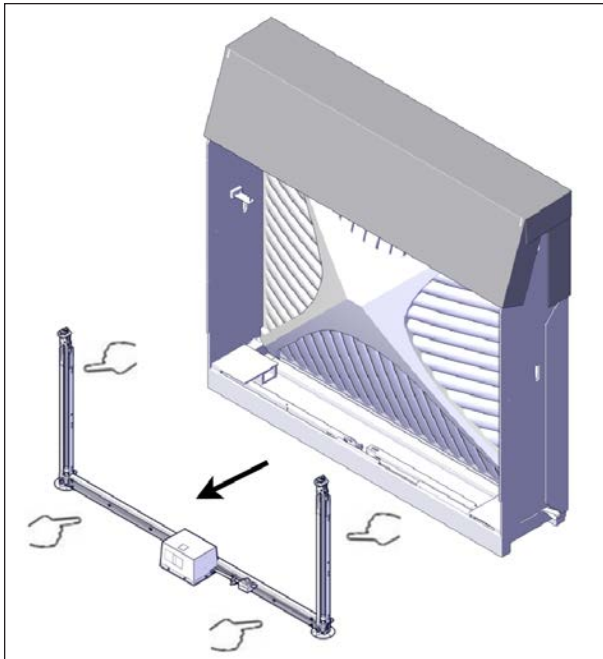

FIGURE 24: MOTOR FRAME ASSEMBLY REMOVAL

CAUTION

Do not twist the motor frame assembly, since this may cause mechanical failure to the operator and chain assembly.

Jacks may be greasy; wash your hands after handling them or use gloves.

Do not damage the jack or frame components resting at the bottom of the crate

12. Pry off the footing piece of wood using your hands or a hammer if needed. There is one piece per side see [Figure 25](#).

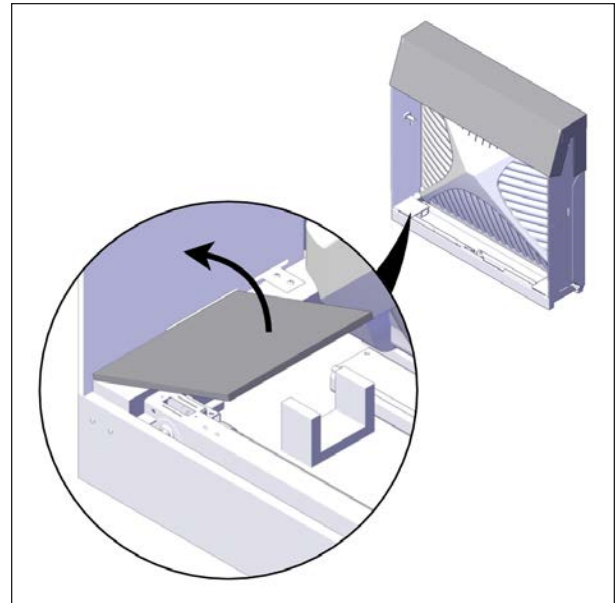

FIGURE 25: FOOTING PIECE OF WOOD REMOVAL

CAUTION

Flatten any protruding nails.

13. Remove the two long U-frames, the two short U-frames and both jacks located at the bottom of the crate. Keep these components in a safe location see [Figure 26](#).

CAUTION

The short U-frames are nailed in; remove them by hand to prevent any aesthetic damage.

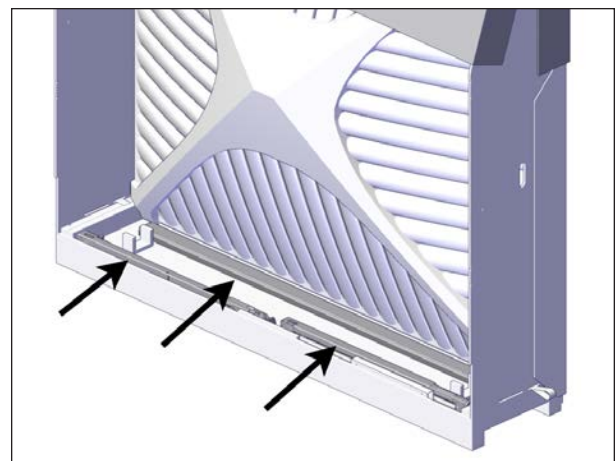

FIGURE 26: JACK AND U-FRAME REMOVAL

14. With the help of another person, gently lay the crate horizontally on its back by using the

pivot point see [Figure 27](#).



CAUTION

Dropping the crate could damage the cover.

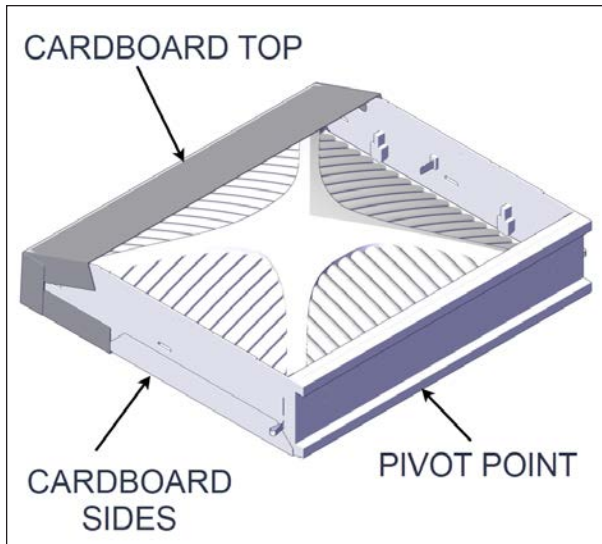

FIGURE 27: LAY THE CRATE ON ITS BACK

15. Remove the cardboard top and sides by simply unfolding them on the ground see [Figure 27](#).
16. If the cover was delivered with roller shades, remove the cardboard cylinders from the holes in the side panels and keep them in a safe location.
17. Gently hammer off the last wood furring strips on the front of the crate. Consider hammering the side panel in an outward direction to prevent damaging the cover see [Figure 28](#).



CAUTION

Be careful not to damage the cover during this process see [Figure 28](#).

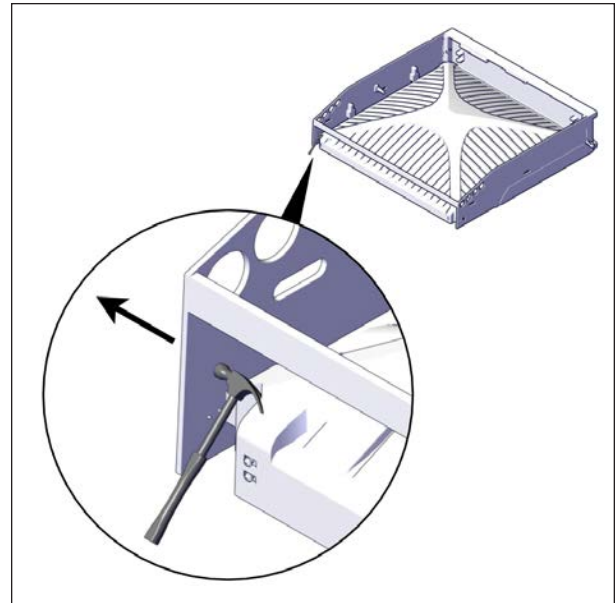

FIGURE 28: WOOD FURRING STRIP REMOVAL

18. This step is divided in 3 substeps:
 - Substep 1: Use a Phillips screwdriver to remove the two M6 x 20 mm screws.
 - Substep 2: Use a 3/8" (10 mm) socket wrench to remove the two other lag bolts.
 - Substep 3: Repeat steps 1 and 2 for all four corners see [Figure 29](#).



CAUTION

Carefully remove all four brackets. Failure to do so might damage the cover when removing the crate sides.

Flatten any protruding nails.

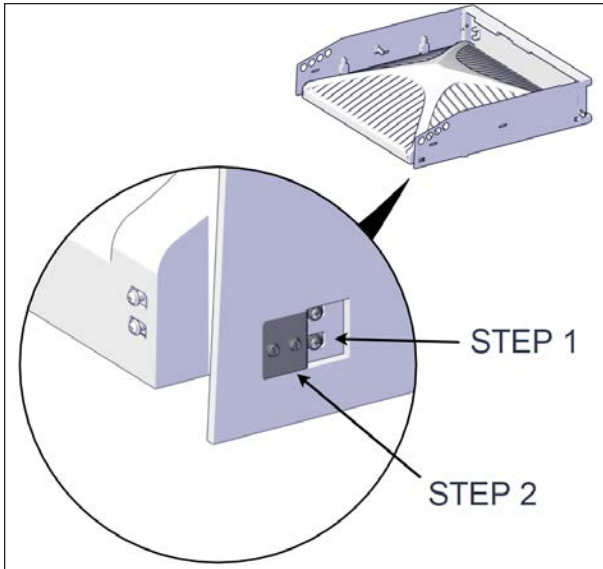

FIGURE 29: COVER BRACKET REMOVAL

19. Use the Robertson screwdriver to remove the three #8 x 1½" screws holding both side panels to the bottom of the crate see [Figure 30](#).

CAUTION

Remove side panels with care. The side panels could fall on the cover.

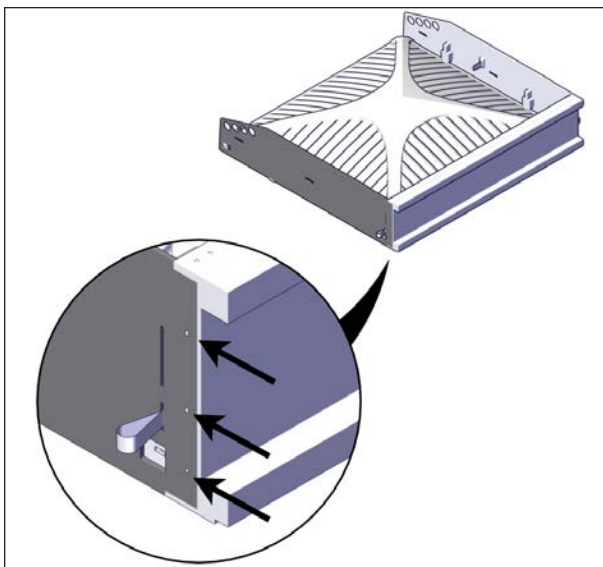

FIGURE 30: SIDE PANEL SCREW REMOVAL

20. Pivot the side panels by gently prying them outward; lay the panels down on the ground see [Figure 31](#).

CAUTION

Do not remove the side panels completely, doing so may damage the cover

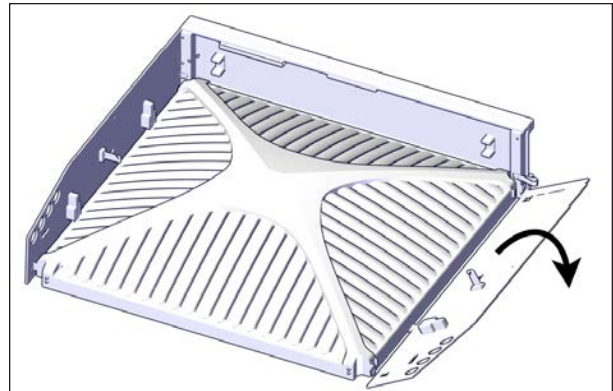

FIGURE 31: PIVOT GENTLY THE SIDE PANELS

21. Pull the bottom section out, making sure that it does not interfere with the cover. If it does, gently lift the cover near the bottom section and continue pulling it out see [Figure 32](#).

CAUTION

Do not flip the bottom section, this might scratch the cover if the nails are protruding from the wood. Pulling the bottom section is the best method to ensure no aesthetic damage.

Flatten any protruding nails.

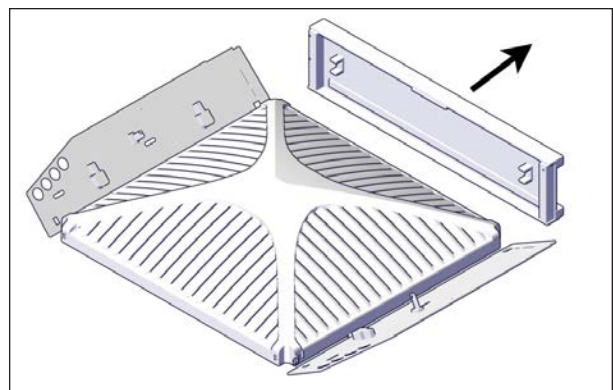
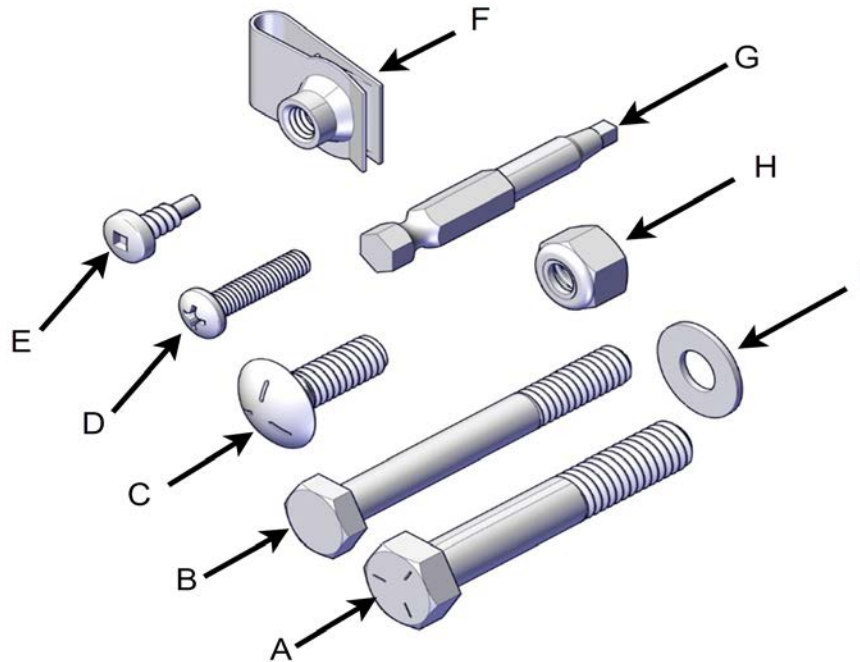

FIGURE 32: BOTTOM SECTION REMOVAL

HARDWARE IDENTIFICATION TABLE



ID	QTY	DESCRIPTION
A	17	5/16-18 x 2" HEX BOLT USED TO ASSEMBLE THE LOWER FRAME
B	4	1/4-20 x 2 1/4" HEX BOLT USED TO ASSEMBLE THE FEET OF THE POSTS
C	4	1/4-20 x 3/4" CARRIAGE BOLT USED TO ASSEMBLE THE FRONT FRAME CUT-OUT
D	19	M6 x 20 mm SCREW USED TO FASTEN THE COVER AND SLEEVE
E	17	#8 x 1/2" SELF-DRILLING SCREW TO FASTEN THE INNER SLEEVE TO THE COVER
F	2	M6 CLIP-ON NUT TO SECURE THE SLEEVES ON EACH POST
G	1	#2 x 6" ROBERTSON BIT
H	8	1/4-20 NYLON-INSERT LOCKNUT TO FASTEN POST FEET WITH FRONT CUT-OUT
	17	5/16-18 NYLON-INSERT LOCKNUT USED TO CONNECT THE U-FRAMES
I	33	5/16" NYLON WASHER USED TO CONNECT THE U-FRAMES
	17	1/4" PAINTED WASHER
	2	1/4" NYLON WASHER TO FASTEN SLEEVE BOTTOM WITH M6 X 20 mm SCREW

ASSEMBLY PREPARATION



WARNING

Before assembling, keep in mind to not over tighten the screws. Power tools must not be used. The screws may break if the torque is too much.

1. Install foam spacers on the top of the spa near each corner. Use the masking tape provided in the seal bag to keep the spacers in place. Install at least 3 foam spacers on each longest side. Do not stack foam spacers see [Figure 33](#).



CAUTION

The foam pieces must be placed on the flat top surface of the hot tub.

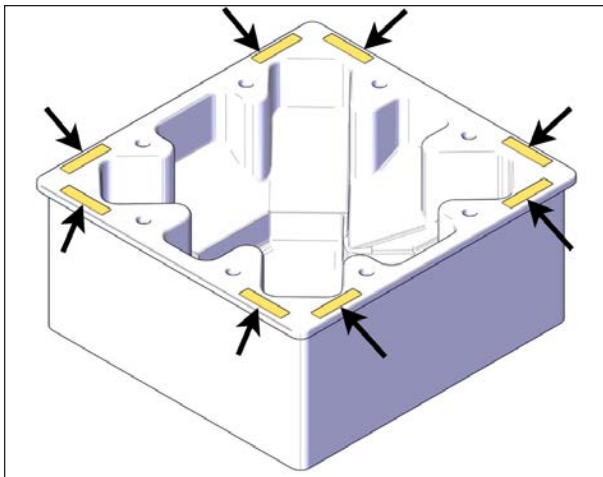

FIGURE 33: FOAM SPACER INSTALLATION

2. Install the top section of the cover on the spa and center it as best as possible. Measure the spa dimensions and align the long side of the cover with the longest side of the spa see [Figure 34](#). If a LED light kit is included, the light switch should be placed on the entry side of the spa.

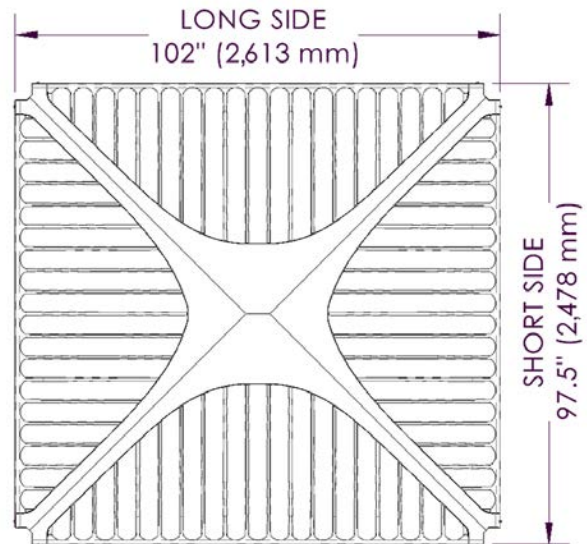

FIGURE 34: RECTANGULAR COVER

NOTE

The cover is rectangular [Figure 34](#). The standard model will need the motor frame to be on the short side of the cover, whereas the long-side will need the motor frame on the long side of the cover.



WARNING

The cover alone weighs approximately 185 lb. (84 kg).



CAUTION

When handling the cover, both people must support the outer and inner shells with their hands. A wide grip is best when handling the cover, as all four sides must be lifted equally.

Three to four people may be required. If the cover is too heavy to handle, remove the outer shell. Be careful not to fold the outer shell or scratch it on the inner steel frame.

LIFTING MECHANISM INSTALLATION (PART 1)

1. Install the motor frame in place, usually to the opposite side of the spa entrance see [Figure 35](#). The standard model will need the motor frame to be on the short side of the cover,

whereas the long-side model will need the motor frame on the long side of the cover.

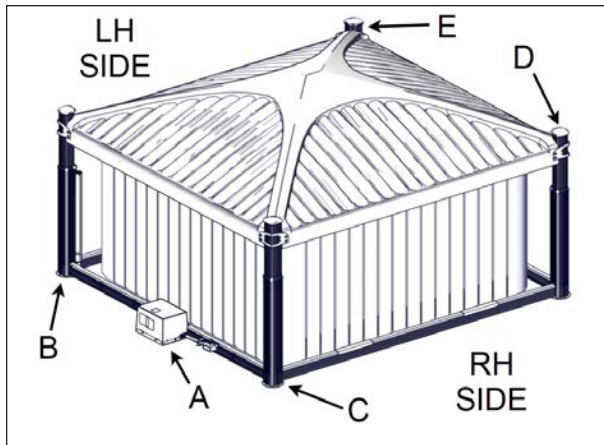

FIGURE 35: OPERATOR AND JACKS INSTALLATION

ID	DESCRIPTION
A	OPERATOR
B	MOTOR LEFT-HAND SIDE JACK
C	MOTOR RIGHT-HAND SIDE JACK
D	NON-MOTOR RIGHT-HAND SIDE JACK
E	NON-MOTOR LEFT-HAND SIDE JACK



WARNING

Do not remove the alignment bracket on the top of the jack (red part).

IMPORTANT NOTE

The next steps are side-specific. They are for the non-motor left-hand side foot assembly.

2. Install a foot bracket to the non-motor side jack. Make sure to align the foot bracket on the right side of the U-frame shaft as shown see [Figure 36](#).

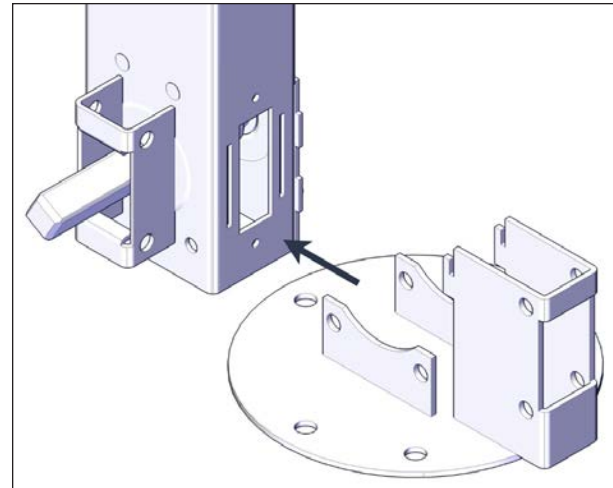

FIGURE 36: FOOT BRACKET INSTALLATION

3. Slide the alignment vertical legs of the foot in the bottom alignment slots of the jack see [Figure 36](#) and [Figure 37](#).

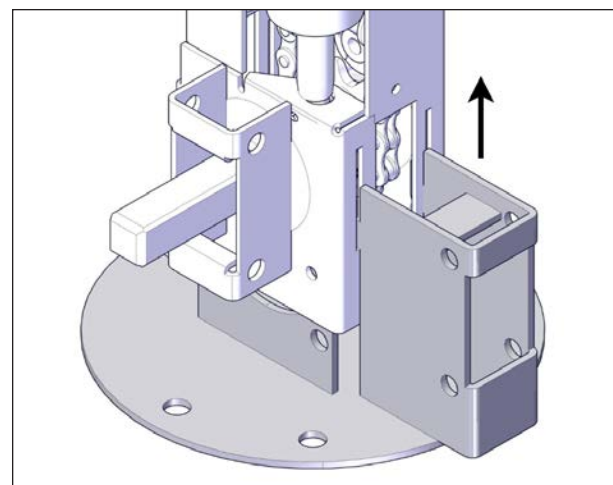

FIGURE 37: INSERT LEGS IN SLOTS

4. Push upwards to lock in place see [Figure 37](#). Make sure to get a full contact with the bottom plate. Use a rubber mallet if necessary.
5. Install two 1/4" x 2 1/4" hexagonal head screws and nylon- insert lock nuts. Use the appropriate socket wrench spanner to fasten the foot in place see [Figure 38](#).



WARNING

To prevent the mechanism from bending inward, do not overtighten the screws.

Make sure you respect the orientation of the fasteners, as shown in [Figure 38](#).

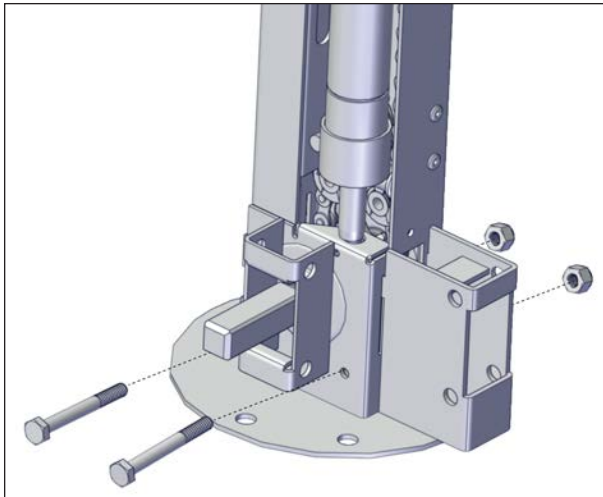

FIGURE 38: SCREW INSTALLATION

6. Repeat previous steps with the non-motor right-hand side foot.

CAUTION

Posts will fall easily when installed upright with the foot installed. Secure the posts by laying them down before proceeding with next step.

7. Position the left non-motor-side jack in the remaining corner of the cover. The square shaft at the bottom of the jack should face toward the motor frame, and the U-frame bracket should be inwards. If not, review the previous steps to install the left and right post feet.
8. Slide the drive shaft over the square shaft located at the bottom of the left motor-side jack assembly see [Figure 39](#).

NOTE

The drive shafts are in the two long U-frames. Remove the plastic film to locate them.

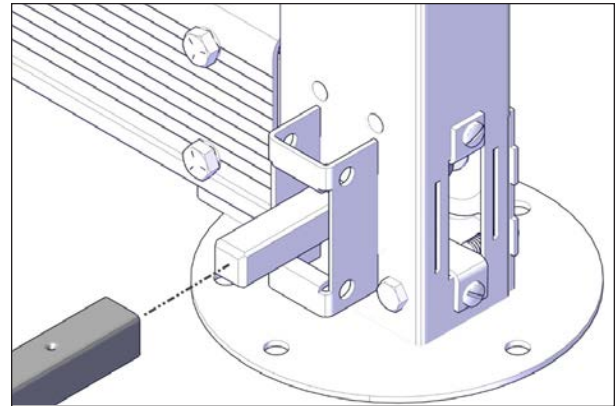

FIGURE 39: DRIVE SHAFT INSTALLATION

9. Hold the left-hand non-motor-side jack assembly upright and in line with the left drive shaft. Use a 3/4" adjustable wrench to carefully rotate the square shaft of the jack to align with the drive shaft [Figure 40](#).

CAUTION

Make sure the drive shaft is fully installed before proceeding further in the installation process. Using the jack without the drive shaft properly connected may cause injury.

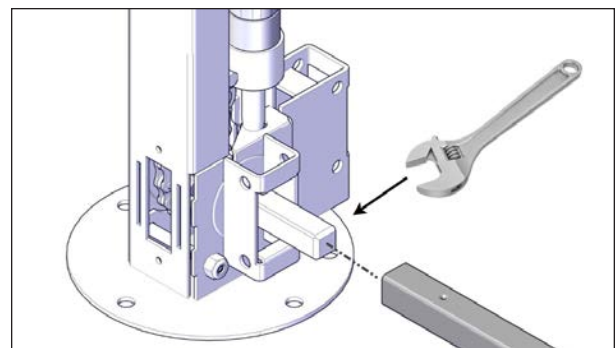

FIGURE 40: DRIVE SHAFT INSTALLATION

10. Install the long aluminum U-frame over the left drive shaft and make sure it lines up with motor-side and non-motor-side jack assemblies. Fasten in place using two hexagonal 5/16"-18 x 2" screws, two 5/16"-18 nylon-insert lock nuts and four 5/16" plastic washers (2 by side), with the 1/2" (13 mm) socket wrench and spanner as tools see [Figure 41](#).

NOTE

Do not fully tighten screws.

The drive shaft may fall off during operation, and reassembling can be done faster when the bolts have not been fully tightened see [Figure 41](#).

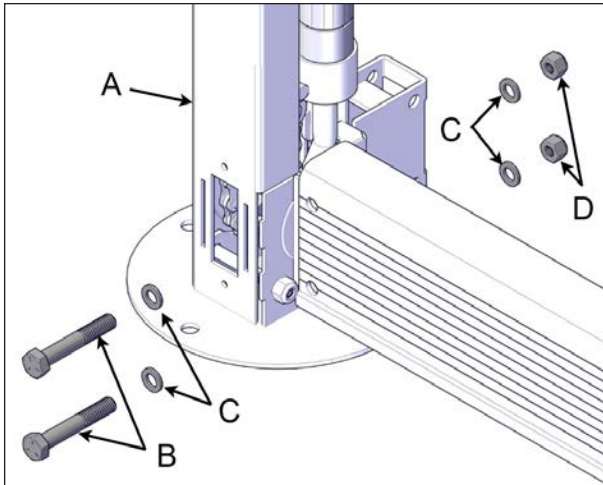

FIGURE 41: LONG U-FRAME INSTALLATION

ID	DESCRIPTION
A	NON-MOTOR SIDE JACK
B	5/16" x 2" HEX HEAD SCREWS
C	PLASTIC WASHER
D	NYLON INSERT LOCKNUT

11. Repeat previous steps on the opposite side.
12. Install one unpainted metal coupler on each end of the spa entrance U-frame link see [Figure 42](#).
13. Align one coupler with the holes on each end of the spa entrance U-frame link. Use the provided 1/4" x 3/4" carriage bolts, 1/4" nylon-insert lock nuts and fasten the hardware with the 7/16" (11 mm) socket wrench and spanner. There is one metal coupler per side see [Figure 42](#).

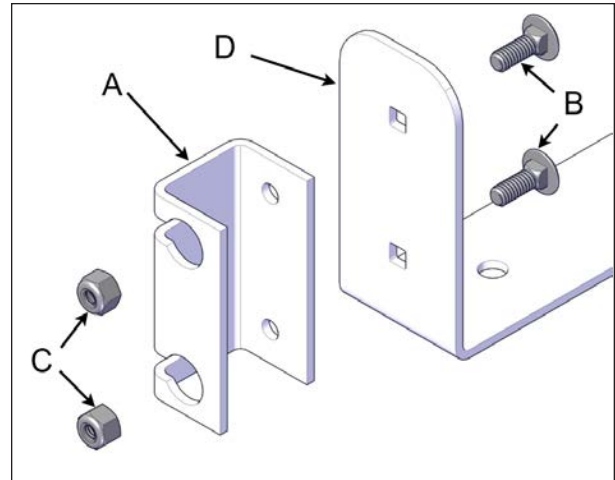

FIGURE 42: SPA ENTRANCE U-FRAME LINK AND METAL COUPLER

ID	DESCRIPTION
A	UNPAINTED METAL COUPLER
B	1/4" x 3/4" CARRIAGE BOLT
C	1/4" NYLON INSERT LOCK NUT
D	SPA ENTRANCE U-FRAME LINK

14. Fasten a short U-frame to each end of the spa entrance U-frame link and then install the entire assembly between the front posts. Use four hexagonal 5/16"-18 x 2" bolts, four 5/16"-18 nylon-insert lock nuts and eight 5/16" washers (4 by side). Use 1/2" (13 mm) socket wrench and spanner see [Figure 43](#).

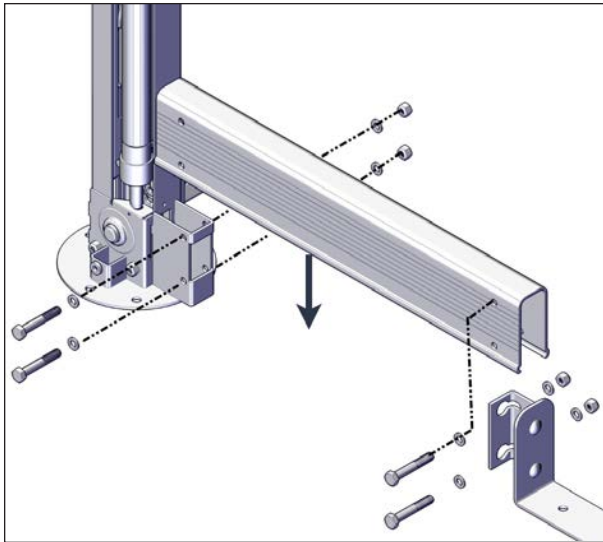

FIGURE 43: SHORT U-SHAPE INSTALLATION

15. Check whether the drive shafts fell off during installation. If so, review the previous steps. If not, tighten all U-frame screws.



DANGER

Failure to verify the proper installation of the drive shafts could result in the non-motor-side jacks extending on their own.

16. Once all the drive shafts are installed, the jack lock screws located at the top of the non-motor-side jacks can safely be removed. Remove the Allen M8 x 50 mm screws and keep them for future use see [Figure 44](#).



WARNING

Failure to remove the locking screws will damage the lifting mechanism when operating.

Do not remove the alignment bracket on the top of the jack.

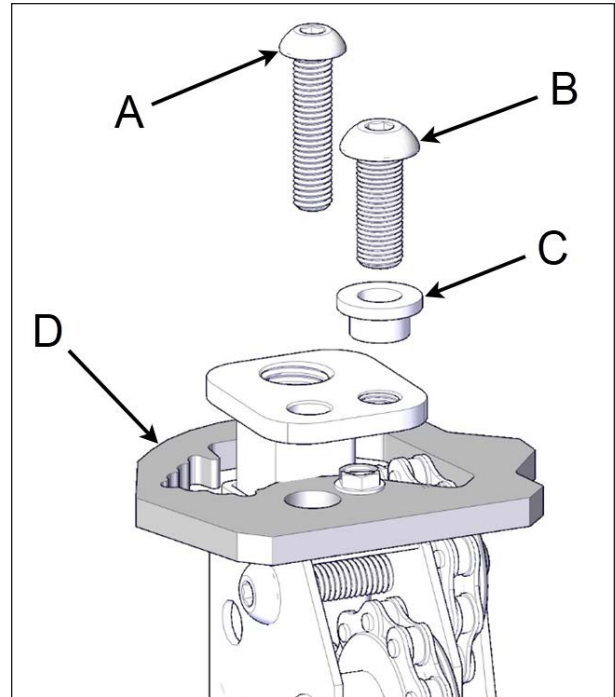

FIGURE 44: JACK LOCK SCREW

ID	DESCRIPTION
A	M8 x 50mm JACK LOCK SCREW
B	3/8" x 1" SOCKET HD SCREW
C	BUSHING
D	ALIGNMENT BRACKET (RED)

17. Unscrew the 3/8" x 1" Allen bolt with a 7/32" (5.5 mm) socket on the top of all four jack assemblies. Put these parts in a safe location see [Figure 44](#).
18. Install the clip-on barrel nuts at the bottom of the non-motor-side jack assemblies to hold the sleeves in the bottom. Use Phillips M6 x 20 mm screws and 1/4" nylon washers. Only the non-motor-side jack assemblies need clip-on barrel nuts to be installed see [Figure 45](#).

NOTE

Do not fully screw in the M6 screws; a gap is needed to slip on the sleeves.

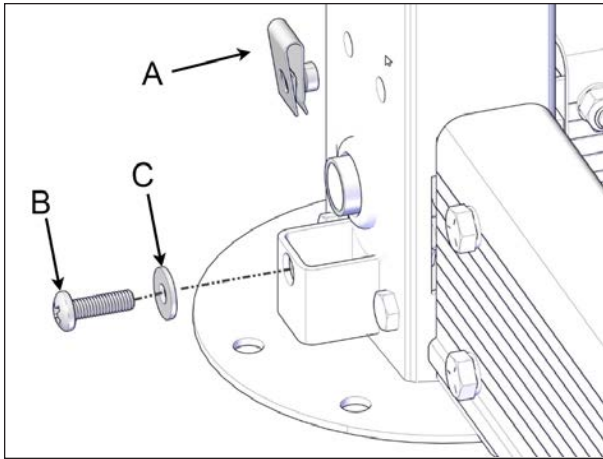

FIGURE 45: CLIP-ON BARREL NUT INSTALLATION

ID	DESCRIPTION
A	CLIP-ON BARREL NUT
B	M6 SCREW
C	1/4" NYLON FLAT WASHER

19. Slide the sleeves over all four jacks see [Figure 46](#).

NOTE

Be sure to align the cutouts at the bottom of the sleeves with the U-frames.

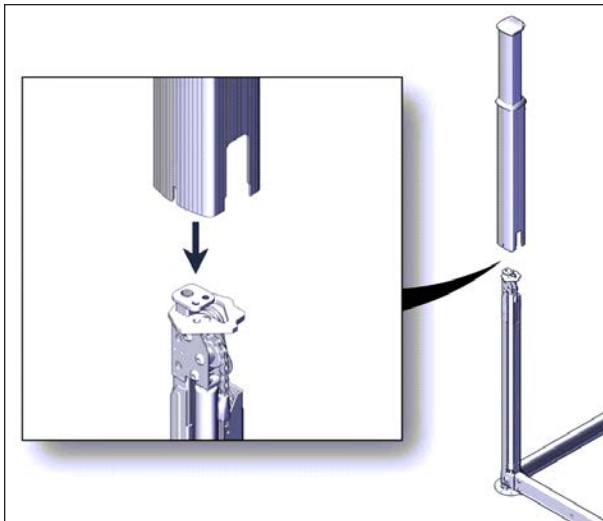

FIGURE 46: SLEEVE INSTALLATION

20. Fasten the sleeve with the Phillips M6 x 20 mm screws at the bottom of all four sleeves see [Figure 47](#).

CAUTION

Make sure that the nylon washer is located on the outside of the outer sleeve.

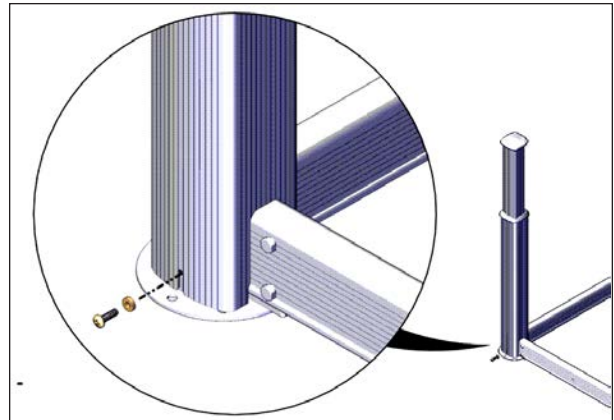

FIGURE 47: MOUNTING SCREW ON THE SLEEVE

21. Make sure the sleeve seal on each post is slid all the way down against the top of the outer sleeve see [Figure 48](#).

WARNING

Failing to properly position this seal may cause serious damage to the post mechanism.

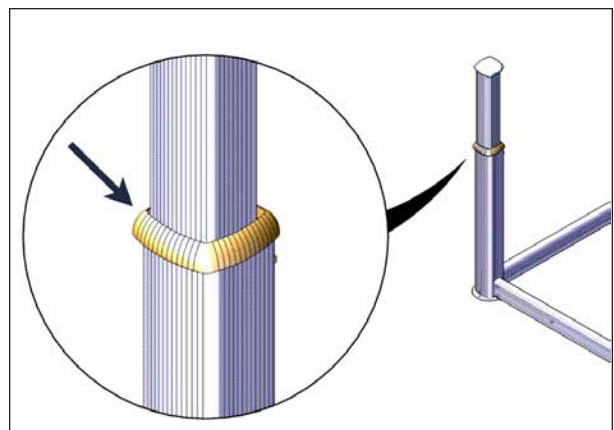

FIGURE 48: SLEEVE SEAL INSTALLATION

22. Install the 3/8" x 1" Allen screw with a 7/32" (5.5 mm) socket previously removed from the jacks, with the smaller diameter of the bushing facing down for each post see [Figure 49](#).

CAUTION

Make sure that the wider part of the bushing is facing up when you screw in the 3/8"-24 x1" Allen bolt see [Figure 49](#).

Ensure the hole in each top plate is aligned with the jack assembly's threads before installing the screw see [Figure 49](#).

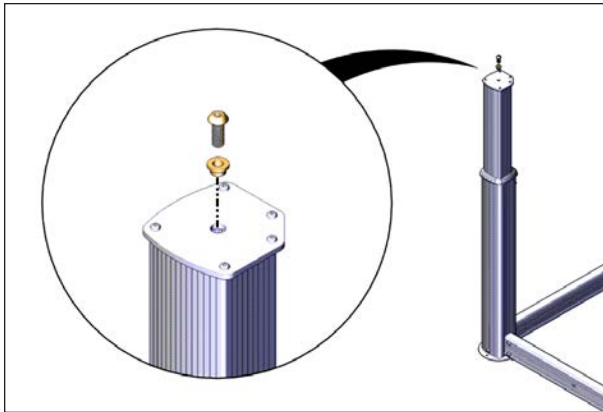

FIGURE 49: FASTEN THE SLEEVE TO THE JACK

AC LIGHT KIT INSTALLATION

If the cover comes with a light kit, follow the steps below. If not, skip to next section the Lifting mechanism installation (part 2).

1. Before splitting the cover into two pieces, fully unscrew any bolts on all four corners that fasten the outer shell to the inner shell if needed.
2. Locate the light switch button see [Figure 50](#).

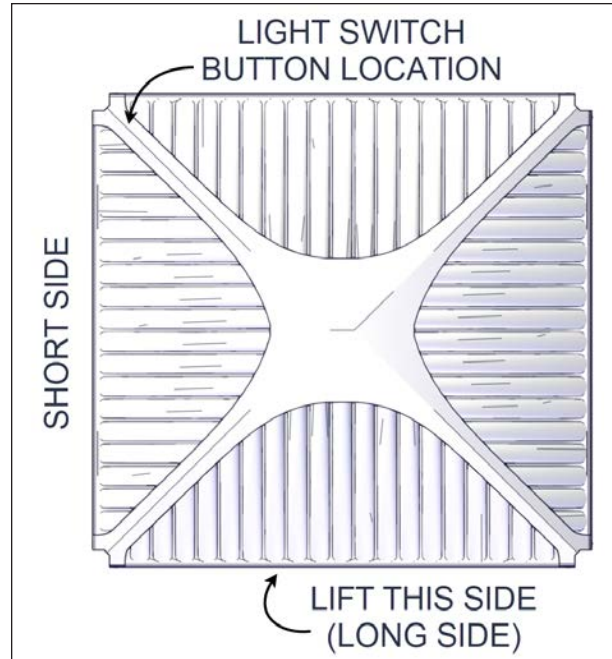

FIGURE 50: SHORT AND LONG SIDES OF THE COVER

3. Lift and split the long side of the outer shell opposite to the light switch button for the next steps. To split the cover into two parts, you must remove the outer shell by pushing inwards on the steel frame of the inner shell see [Figure 50](#) and [Figure 51](#). This will clear the metal inserts from the outer shell for better leverage. Do not lift more than 16" (40 cm).

NOTE
A non-abrasive or blunt tool may be used to help hold the outer shell in place before moving to the next steps.

CAUTION
 Do not use any sharp or abrasive tools to hold the outer shell in place while following the next steps.
 You should always hold the outer shell on the long side at two different points spaced by about 34" (85 cm)

WARNING
 Do not lift the corners more than 16 in (40 cm), further lifting may damage the outer shell.
 Failure to follow this instruction will cause permanent damage to the outer shell.

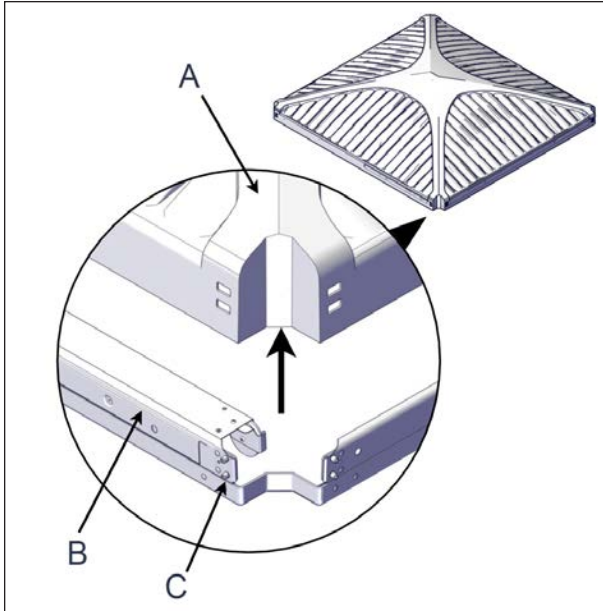

FIGURE 51: OUTER SHELL LIFTING

ID	DESCRIPTION
A	OUTER SHELL
B	STEEL FRAME
C	METAL INSERT

4. While holding the outer shell open, cut and remove the two cable ties that hold the wire guard see [Figure 52](#) and [Figure 53](#).



WARNING

Completely remove both cable ties and discard them. They could interfere with the CTS-70 mechanism.

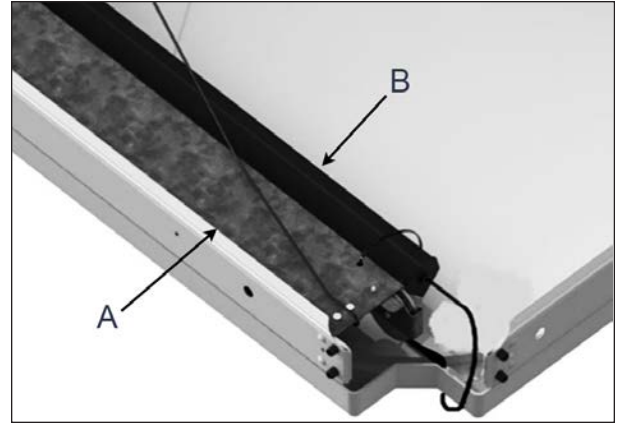

FIGURE 52: CABLE TIE REMOVAL

ID	DESCRIPTION
A	CTS-70 (CONTINUOUS TENSION SYSTEM)
B	WIRE GARD

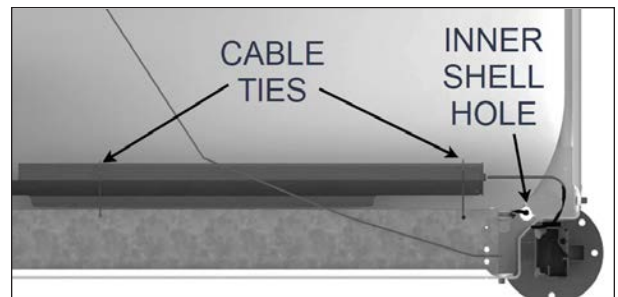

FIGURE 53: CABLE TIE LOCATIONS

5. Open the wire guard by ripping the plastic off. The plastic bag includes two bottles of primer and an alcohol swab; put those items in a safe location.
6. Gently remove the wire guard from the inner shell. Let the wire guard hang down for the next steps.



WARNING

Ensure the wire is clear of the inner and outer shells before proceeding. The wire should only hang from the inner shell hole see [Figure 53](#).

7. Clean the surface of the outer sleeve positioned on the opposite corner of the light button. Remove any dirt or contaminant and dry the surface see [Figure 55](#) and [Figure 56](#).

8. Use the supplied alcohol swab and rub it on the surface of the outer sleeve positioned on the opposite corner of the light button to clean the surface see [Figure 55](#) and [Figure 56](#). Wait two minutes for the alcohol to dry.
9. Apply the primer on the inside corner of the indicated areas. Refer to [Figure 55](#) and [Figure 56](#). The wire guard can also be held in place and taped off around its perimeter to mark off the application area.

IMPORTANT NOTE

Failure to apply the primer will result in the wire guard unsticking over a short period of time. The primer will act as the optimal bonding agent for the paint. To use the primer, snap the bottle in the middle for the liquid to come out see [Figure 54](#).



WARNING

The bottle of primer (3M Primer 94) is considered flammable, a serious irritant for the eyes, a skin sensitizer, an inhalation hazard, toxic for reproductivity, carcinogenic and toxic for internal organs. Please be careful when handling the primer. Ensure proper ventilation prior to and during the use.



FIGURE 54: PRIMER 94

10. Let the primer dry for at least five minutes at temperature above 40°F (5°C). This will ensure an adequate bonding surface.

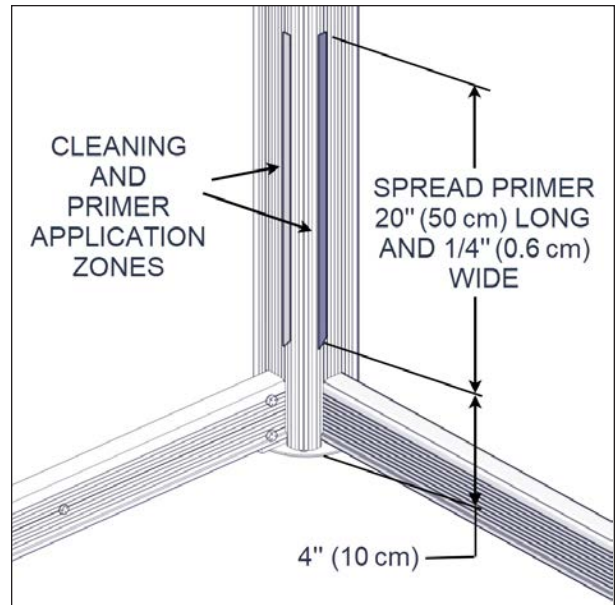

FIGURE 55: AREAS TO CLEAN

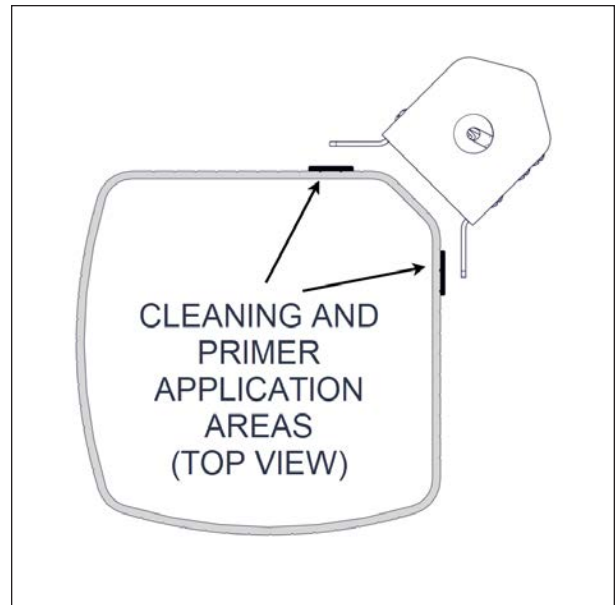

FIGURE 56: AREAS TO CLEAN AND TO APPLY THE PRIMER 94 (TOP VIEW)

11. Peel off a short length of the red plastic film on the double-sided tape, fold the film toward the outside. (Do this step for both sides) see [Figure 57](#).

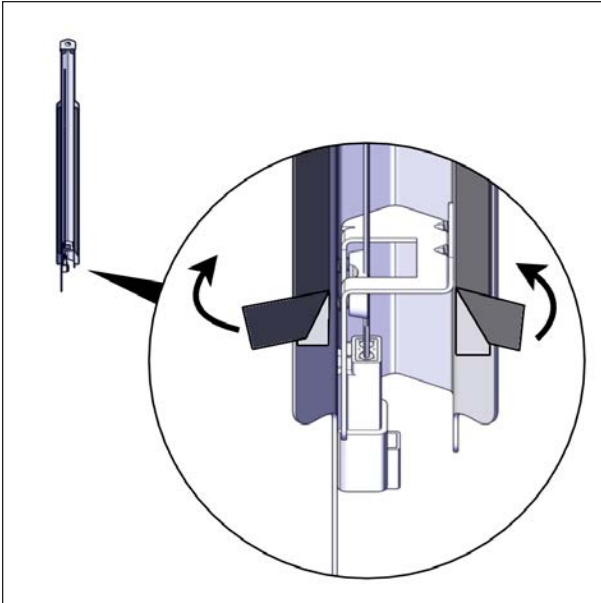

FIGURE 57: RED PLASTIC FILM SHORT PORTION REMOVAL

12. Align and position the bottom of the wire guard on the foot plate that lines up with the inner shell hole see [Figure 58](#).



WARNING

The bottom of the wire guard must be properly positioned on the foot plate. If not, review the previous steps. An improper alignment or positioning of the wire guard may cause the system to misadjust itself.

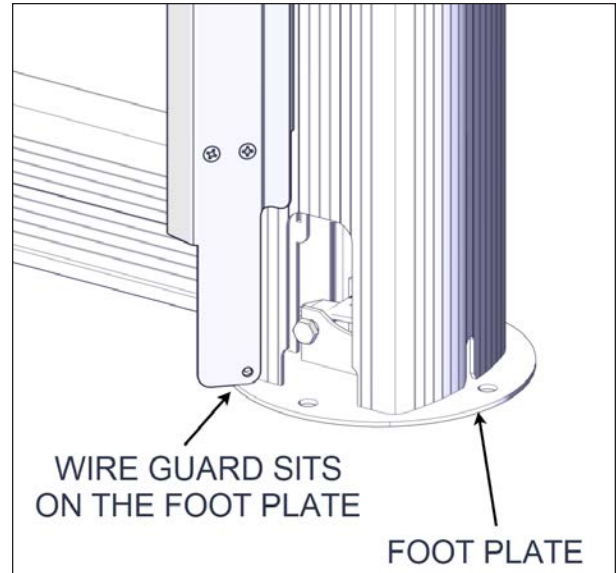

FIGURE 58: WIRE GUARD BOTTOM POSITION

13. Fit the wire guard on the corner of the post. Make sure no wires are pinched and that the wire guard is well leveled before adhering it to the sleeve see [Figure 58](#) and [Figure 59](#).

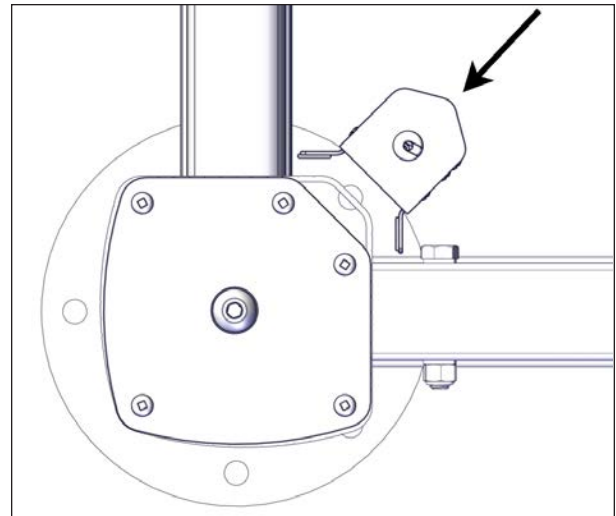

FIGURE 59: WIRE GUARD POSITIONING

14. While still holding the wire guard on the post, gently start peeling away the red film one side at a time. This method will ensure proper alignment. Hold for at least one minute to ensure a proper bond see [Figure 60](#).



WARNING

A good pressure is needed to ensure that the wire guard bands have a full contact with the sleeve.

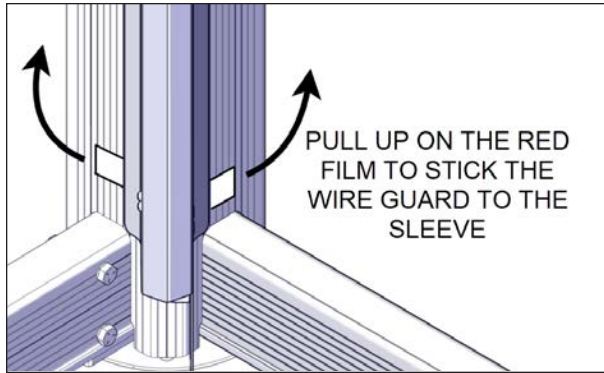

FIGURE 60: RED FILM REMOVAL

- Now connect the bottom harness to the wire guard connector. The bottom harness is attached to the key switch cable. Cut the cable tie that holds the bottom harness. Connect it to the wire guard connector see [Figure 61](#).



WARNING

Never remove the wire guard connector. This could cause permanent damage to the wire harness.

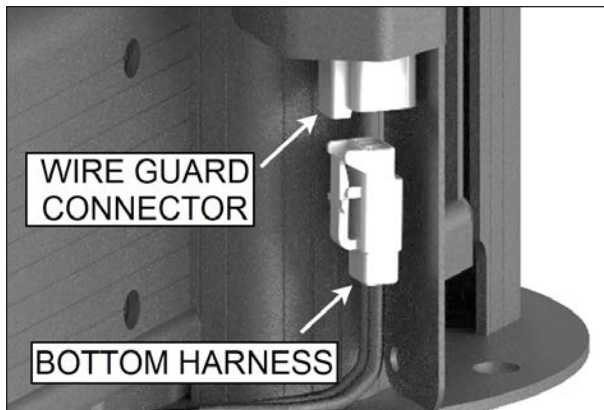

FIGURE 61: WIRE GUARD CONNECTION

- If the cover is completely lowered on the spa, and the exiting wire ([Figure 63](#)) seems to have sufficient tension and the magnetic plate is properly positioned ([Figure 62](#)), move to next section, lifting mechanism installation (part 2). If not, follow the next steps.
- Repeat steps 1 to 3 of this section for outer shell lifting instructions.

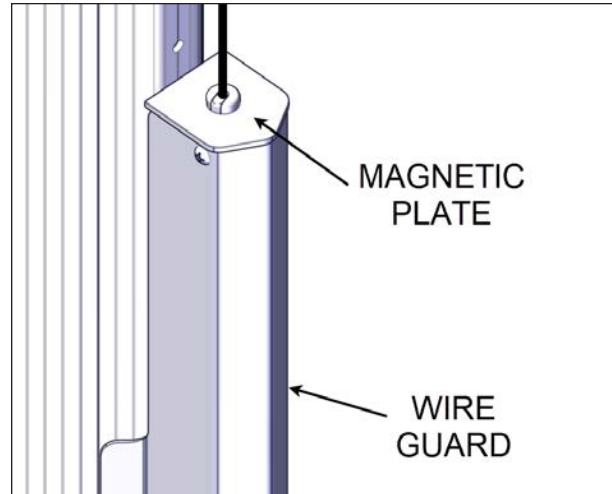

FIGURE 62: MAGNETIC PLATE

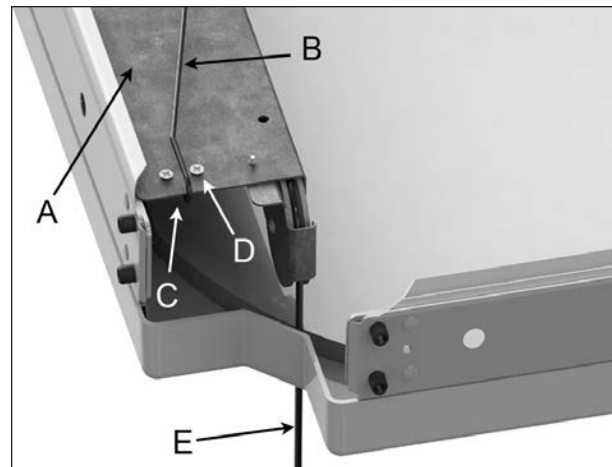

FIGURE 63: EXITING WIRE

ID	DESCRIPTION
A	CTS-70
B	TENSION WIRE (GOING TO LED)
C	TENSION HOLDER
D	SCREW
E	EXITING WIRE (GOING TO OPERATOR)

- Locate the screws for the tension holder on the CTS-70 (Continuous Tension System) see [Figure 63](#). Lightly unscrew them and pull back the tension wire until a slight resistance is felt. Once the resistance is felt, continue pulling another inch. Check the protruding wire going to the posts, and if the wire is tight enough, retighten the set screws.

19. Slide the outer shell back on the inner shell. The AC light kit has been successfully installed.

CAUTION

When placing the outer shell back on, make sure that all the steel frames are inside the outer shell. Also, check all metal inserts before continuing. Failure to check these items may cause aesthetic damage.

LIFTING MECHANISM INSTALLATION (PART 2)

1. Make sure the cover is centered. Use a measuring tape on all four sides and make sure it is still resting on the foam spacers. If not, center the cover on all four sides.
2. Check if all posts are vertically leveled with a 48" (122 cm) long level. You will need to verify the front and right sides of each post with the level.
3. Next steps show how to install the outer corner brackets (4). [Figure 64](#) shows the installation pattern (four brackets, four corners). Install the first outer corner bracket on corner number 1 and then keep following the pattern for the remaining brackets.

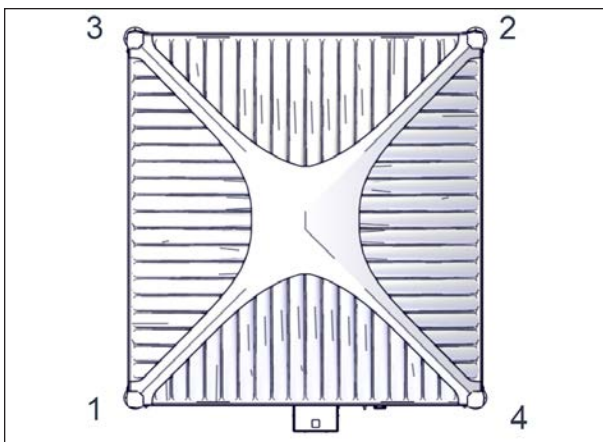

FIGURE 64: INSTALLATION PATTERN FOR THE OUTER CORNER BRACKETS (4)

4. Install the first outer corner bracket as shown in [Figure 65](#). Fasten the bracket to the cover

with four painted Phillips M6 x 20mm bolts and 1/4" painted washers. Install the first screw on position A and for the remaining screws, keep following the pattern shown in [Figure 65](#).

WARNING

Make sure the sleeve is correctly pressed against the outer shell before installing the M6 x 20 mm screws.

NOTE

We recommend orientating the corner bracket with the rounded edge towards the top.

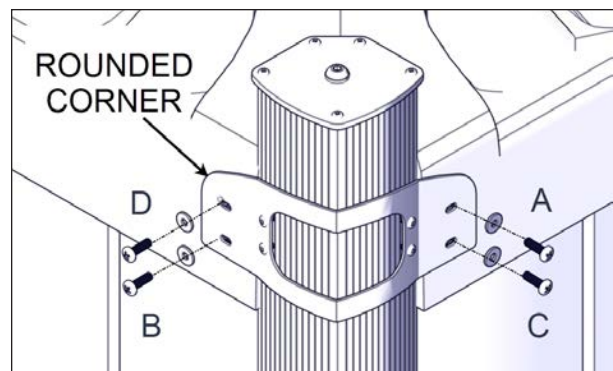

FIGURE 65: INSTALLATION PATTERN FOR CORNER BRACKET SCREWS ATTACHED TO THE COVER

5. Install #8 x 1/2" self-tapping screws (4) to fasten the corner bracket to the sleeve and follow the pattern A to D shown in [Figure 66](#).

CAUTION

Tighten screws with care; self-tapping screws can break when screwed in too hard.

NOTE

When fastening in the screws, it is recommended to pull the post towards you for a better fit of the corner bracket. This will diminish the possible gap.

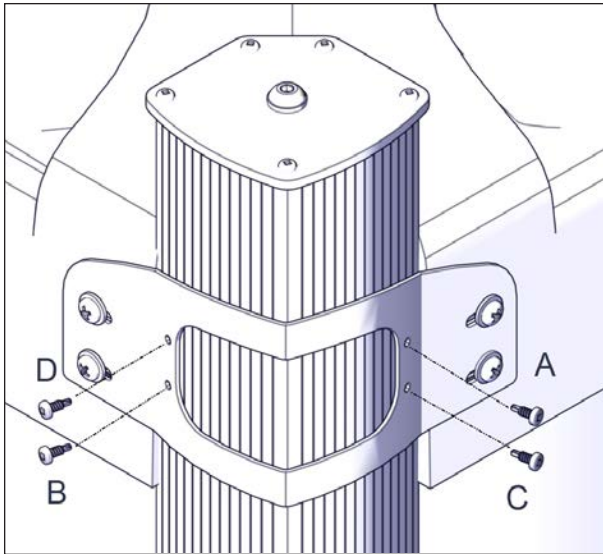

FIGURE 66: INSTALLATION PATTERN FOR CORNER BRACKET SCREWS ATTACHED TO THE SLEEVE



WARNING

Make sure there is no gap between the sleeve and the bracket. If there is a gap, verify the previous step see [Figure 67](#).

Review previous steps before screwing in the Roberston screws; it is very hard to reposition the sleeves once they have already been screwed in. We highly recommend checking whether the posts are level before screwing in the corner bracket.

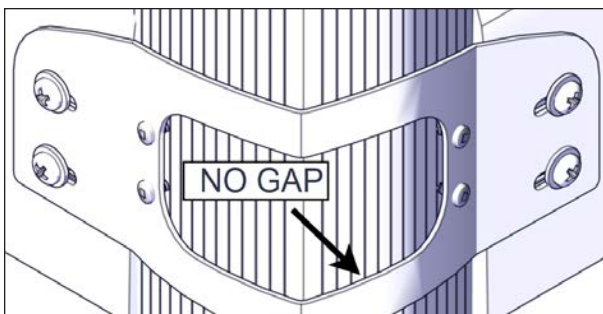

FIGURE 67: NO GAP ALLOWED

6. Repeat the previous steps for all corners.
7. Check the installation of the brackets by trying to lift each sleeve. Review previous steps for any broken screws or to retighten screws if the sleeve keeps moving see [Figure 68](#).

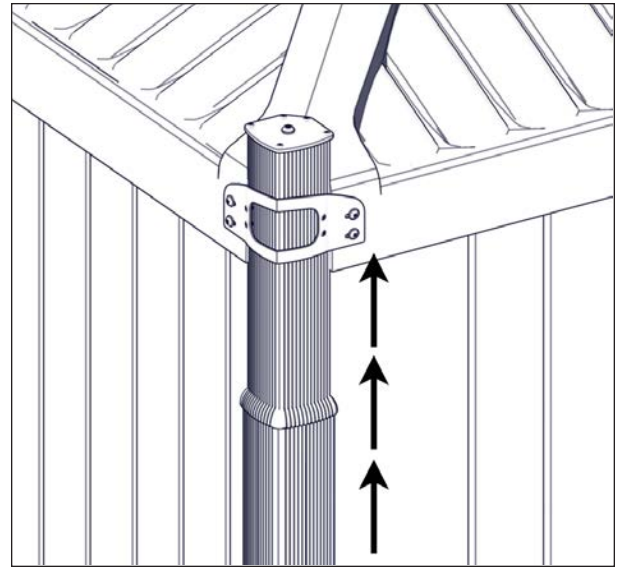

FIGURE 68: SLEEVE INSTALLATION CHECKING

8. Install the rubber caps on all posts. These caps protect the post assembly tops from weathering see [Figure 69](#).

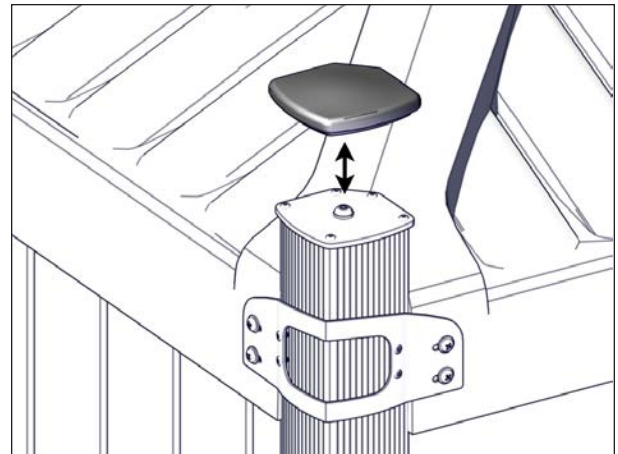

FIGURE 69: RUBBER CAP INSTALLATION

TESTING THE COVER

1. Plug in the cover. Have a certified electrician to complete the electrical hook-up and refer to section Electrical diagrams.



WARNING

All electrical connections must be done by a certified electrician.

2. Make sure there is no object directly above the cover or in its lifting path while performing this test. Refer to the instructions in the [LIMIT SWITCH ADJUSTMENT](#) section if adjustment is required.
3. Use the key in the key switch to lift up the cover to a maximum of 8 in. (20 cm) and then stop the lifting. Make sure the cover is lifting equally (no corners higher than the others).
4. Lower the cover completely and make sure the cover is touching all foam spacers on the spa top perimeter.
5. Lift the cover all the way up and pay attention to any unusual sounds (metal screeching or knocking). If so, consult the [TROUBLESHOOTING](#) section or contact your local dealer.
6. Lower the cover and make sure it stops at the point of contact with all the foam spacers on the spa. If not, adjust the corner brackets (see corner bracket installation in section Lifting Mechanism).
7. Check if the posts are still leveled before anchoring. Use a 48" (122 cm) long level.



CAUTION

When operating the cover, the user must always have a clear view of the cover and its surroundings.

NON-PERMANENT MOUNTING PLATE

If you don't have non-permanent mounting plates, skip this section.

NOTE

This setup is only available for spa base sizes larger than 82" wide for standard Covana units and 87" wide for long side Covana units.

1. After the unit has been installed, but before installing the seal, proceed with the non-permanent mounting plate installation. Using the key switch, lift up the cover to make room to slightly lift up the spa.

NOTE

Three installers are required. Two installers should lift the spa at one end approximately 4" off the ground while the third installer slips the non-permanent mounting plates under the spa and hooks them over the U-frame see [Figure 70](#) and [Figure 71](#).

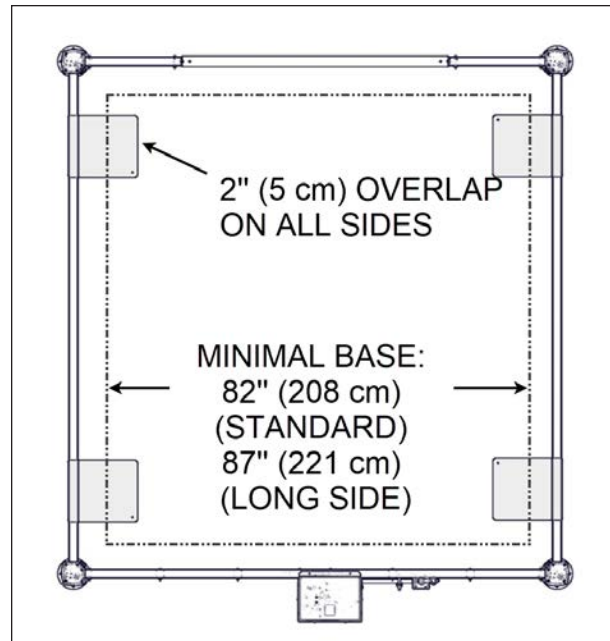

FIGURE 70: LOCATION OF THE PLATES

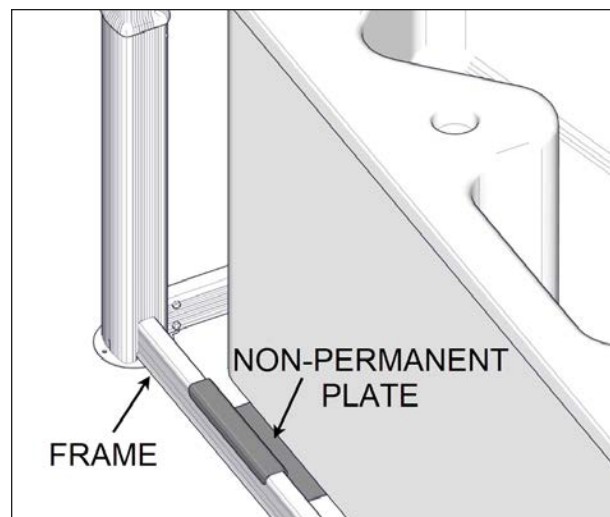

FIGURE 71: PLATE AND U-FRAME

2. Repeat step on the other side as shown on [Figure 71](#)

NOTE

The plates must be installed over the U-frame (two on each side).

3. The proper disposition of the plates is determined by the size of the spa. Position the plates close to the corners of the spa.
4. Once the plates are under both sides of the spa and once they have been properly positioned over the U-frames, you may continue with the seal installation.

SEAL INSTALLATION



WARNING

The recommended tool to install the seal properly is a J-Roller with rubber roller (Covana part no. 239693), see [Figure 72](#).

The roller is not included in the tools. It must be free of scratches, clean and non-abrasive.

Covana is not responsible for any misuse of the tool and any damage done to the spa or the cover while using the roller.



CAUTION

It is recommended to install the seal when the ambient temperature is above 50 °F (10 °C)

Before installing the seal, it is strongly recommended to reduce the water vapor steam generated by the spa. To do this; stop the agitation of the water by turning off the recirculation pump, and then set the temperature of the spa water to be between 2 and 5 degrees under the ambient temperature. Wait until the water has the ambient temperature or use a plastic canvas to stop the vapor steam.

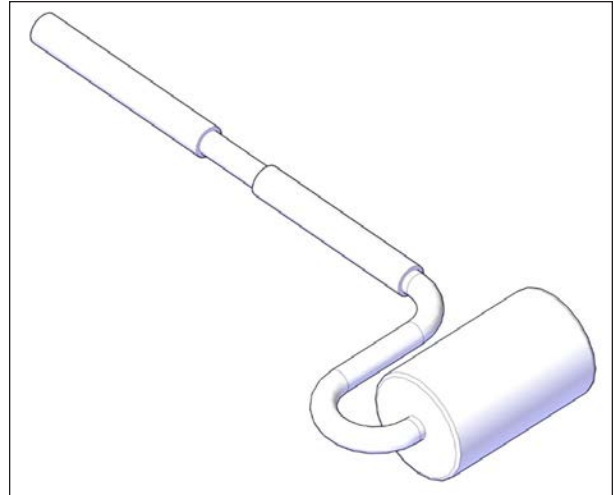

FIGURE 72: J-ROLLER WITH RUBBER ROLLER

1. Once the cover has been fully mounted, raise the cover and remove the foam spacers and tape.

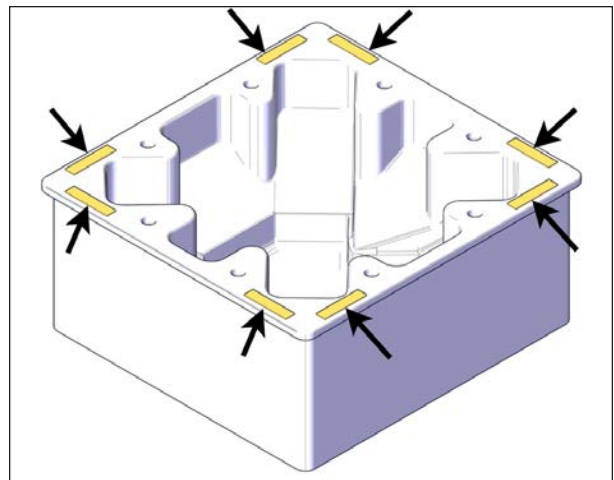

FIGURE 73: REMOVE FOAM SPACERS AND TAPE

2. Lower the cover and walk around the entire perimeter of the spa. Check where the inside surface of the cover makes contact with the spa. This determines the best location to install the seal.
3. Dry the spa top edges and the underside of the cover with a clean cloth.



WARNING

The spa top edges must be 100% dry and clean. Use isopropyl alcohol (IPA) if necessary.

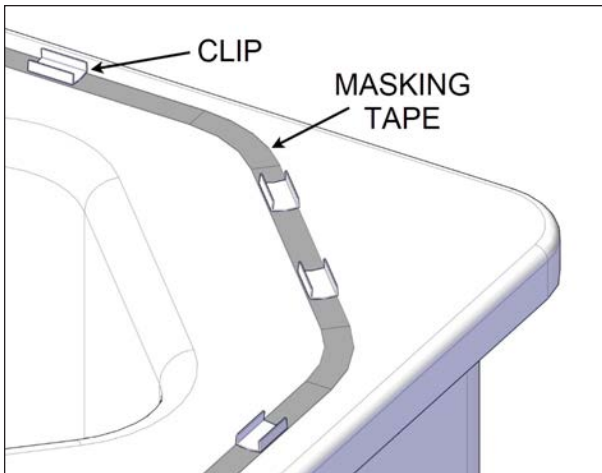

FIGURE 74: MASKING TAPE AND CLIPS

**WARNING**

The use of masking tape is recommended since it will protect the spa acrylic from the clip glue. Furthermore, pulling the masking tape from one corner to the next will ensure straightness.

Install the masking tape at the best location as possible according to the contact surface between the cover and the top edge of the spa.

4. The number of seal clips is limited. Temporarily install the clips all around the spa to ensure the best distribution (do not stick yet). The minimum turn radius for the seal is 4" (10 cm), see [Figure 74](#). Keep two clips for the seal joint connector as shown in [Figure 75](#). Once the distribution is done, stick the clips in place (on the tape if applied).
5. The seal joint starts on the opposite side from the spa entrance. Install two clips where the seal joint connector will be located, see [Figure 75](#).

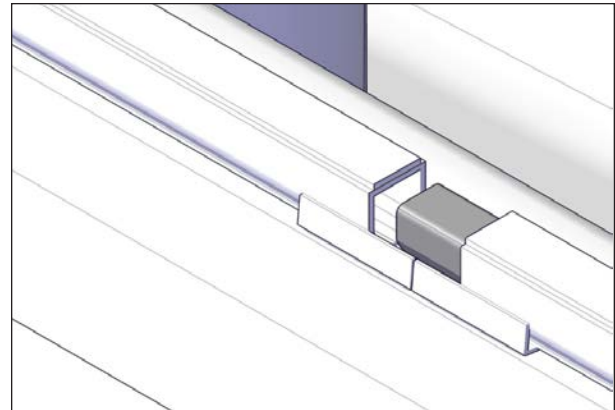

FIGURE 75: SEAL JOINT CONNECTOR

6. Start installing the seal joint with the adhesive layer facing up towards the cover, see [Figure 75](#) and [Figure 76](#).

**CAUTION**

Do not install the seal joint near a control system or the critical components of the spa.

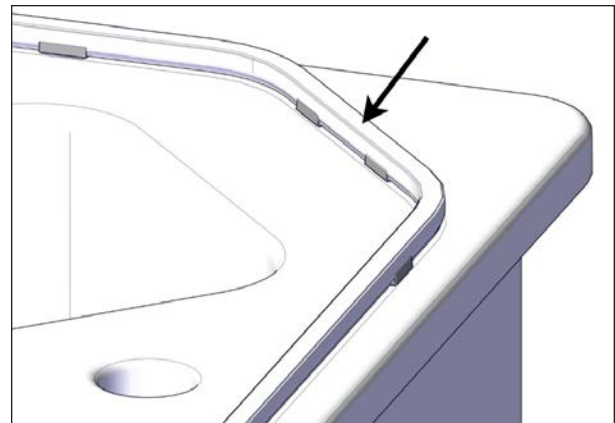

FIGURE 76: SEAL INSTALLATION

7. Once the seal is installed in the clips around the entire spa, cut the extra length as straight as possible for the best joint finishing results.
8. Insert the supplied seal connector in both ends of the seal. The use of masking tape to hold the two ends is recommended, see [Figure 75](#).

**WARNING**

At this point, if there is no water in the spa and the ambient air temperature is below 50 °F (10 °C), a temporary heater must be installed inside the spa for 10 to 15 minutes.

Once the heater is in the spa, lower the cover until it touches the seal to increase the air temperature.

While generating heat, regularly check interior air temperature and do not let it reach temperatures above 104 °F (40 °C). After 10 to 15 minutes, remove the heater and continue with the seal installation.

The rubber seal should not be overheated. Do not directly heat the acrylic or seal, as this may cause permanent damage.

Do not install the heater too close to the acrylic surface, as the surface could melt or catch on fire.

Install the heater on a pedestal or spacers so it will not rest directly on the acrylic of the spa.

**WARNING**

Make sure that the air temperature in the spa is still between 68 °F and 104 °F (20 °C and 40 °C) before proceeding to the next steps.

Remove all dirt, oil residues and moisture from the underside of the cover for proper seal adhesion, especially in wet spa installations. The use of mild detergent can help clean the surface.

Make sure the seal stays tight in the clips to ensure its proper positioning.

9. Test the seal placement by lowering the cover about 1/4" (6 mm) over the seal to ensure that the entire perimeter will make contact with the seal. If you are satisfied, raise the cover and remove the red plastic backing off the seal.
 10. Completely lower the cover onto the seal. Leave the cover in this position for at least 5 minutes to ensure a proper seal-to-cover adhesion.
 11. Slowly lift up the cover no more than 1/4" (6 mm) and leave the cover in this position for about 10 seconds, as this will allow the seal to slowly and fully release from the seal clips. You can also use a non-abrasive plastic tool
- or your fingers to help release the seal from the clips.
12. Once satisfied that the seal is released, lift up the cover 36" (91 cm) high. Apply a minimal pressure of 15 psi (103 kPa) on the seal with the roller as shown in [Figure 77](#) to properly bond the adhesive to the underside of the cover.

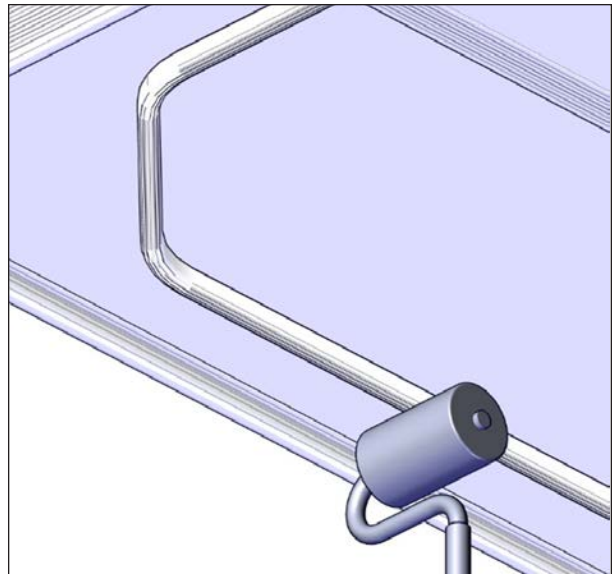
**FIGURE 77: APPLY PRESSURE WITH ROLLER**

13. Remove all seal clips and tape (if applied) from the spa top edges.
14. Lower the cover and stop at approximately 6" (15 cm) from the spa top edges.
15. Make sure the cover is flat with all corners at the same height.
16. Lower the cover, and make sure the seal is touching the spa all around. The heater can be put back in place if necessary.
17. Completely lower the cover and leave it closed for at least 24 hours. This will ensure the seal is properly bonded to the cover surface. The heater can be put back in place if necessary.
18. The seal installation is completed.

ELECTRICAL CONNECTIONS

This section shows you how to connect electrical wiring to operate the cover.

RISK OF ELECTROCUTION



CAUTION

All electrical work should be done by a certified electrician, otherwise the certification and warranty will be void. Furthermore, any modifications to the electrical components will also void the warranty.



DANGER

Failure to comply with these instructions may result in death by electrocution or serious injury



DANGER

- Disconnect or turn off and secure all power supplies before starting any intervention on the cover.
- A circuit breaker needs to be incorporated into the fixed wiring at the time of installation. This circuit breaker must be accessible to the user or service technician to turn the power off for future maintenance or repair.
- Only a certified electrical contractor may perform any electrical maintenance on the cover. The wiring must comply with all applicable local electrical regulations.
- The operator must be connected to a circuit that is protected by a dedicated ground fault circuit interrupter (GFCI) that complies with all applicable local electrical codes and regulations.
- Install the cover in such a way that drainage directs water away from the electrical and the mechanical components at the base.
- Do not connect any auxiliary components to the electrical system of the cover unless they have been approved by Covana.
- Replace electrical components with original components provided or approved by Covana. Ask your dealer for replacement parts.
- To reduce the risk of electrical shock, replace a damaged electrical cord immediately. Failure to do so may result in death or serious personal injury due to electrocution.
- Do not bury the electrical wires into the ground unless using a direct-burial underground cable. Not respecting this precaution may result in death, or serious personal injury due to electrocution.

ELECTRICAL WARNING



WARNING

- To reduce the risk of electrical shocks, the green-colored terminal (or the terminal marked “g,” “gr,” “ground,” “grounding” or with a \equiv symbol) that is located inside the supply terminal box or compartment must be connected to the grounding connection provided in the electric supply service panel with a continuous copper wire equivalent in size to the circuit conductors supplying the equipment.
- Two lugs marked “bonding lugs” are provided on the external surface or on the inside of the supply terminal box or compartment. To reduce the risk of electric shock, connect the local common bonding grid in the area of the cover. Use terminals with an insulated or bare copper conductor not smaller than No. 6 AWG (4.11 mm / 13.30mm²).
- All field-installed metal components, such as rails, ladders, drains or other similar hardware, within 10 ft (3 m) of the spa must be bonded to the equipment grounding bus with copper conductors not smaller than No. 6 AWG (4.11 mm / 13.30mm²). (NEC art. 680).

GROUNDING AND POWER SUPPLY CONNECTIONS

1. Remove the screws (4) on the bottom side of the operator cover and remove the cover see [Figure 79](#).
2. For the complete wiring diagrams refer to section Electrical diagrams (North American models and European models).

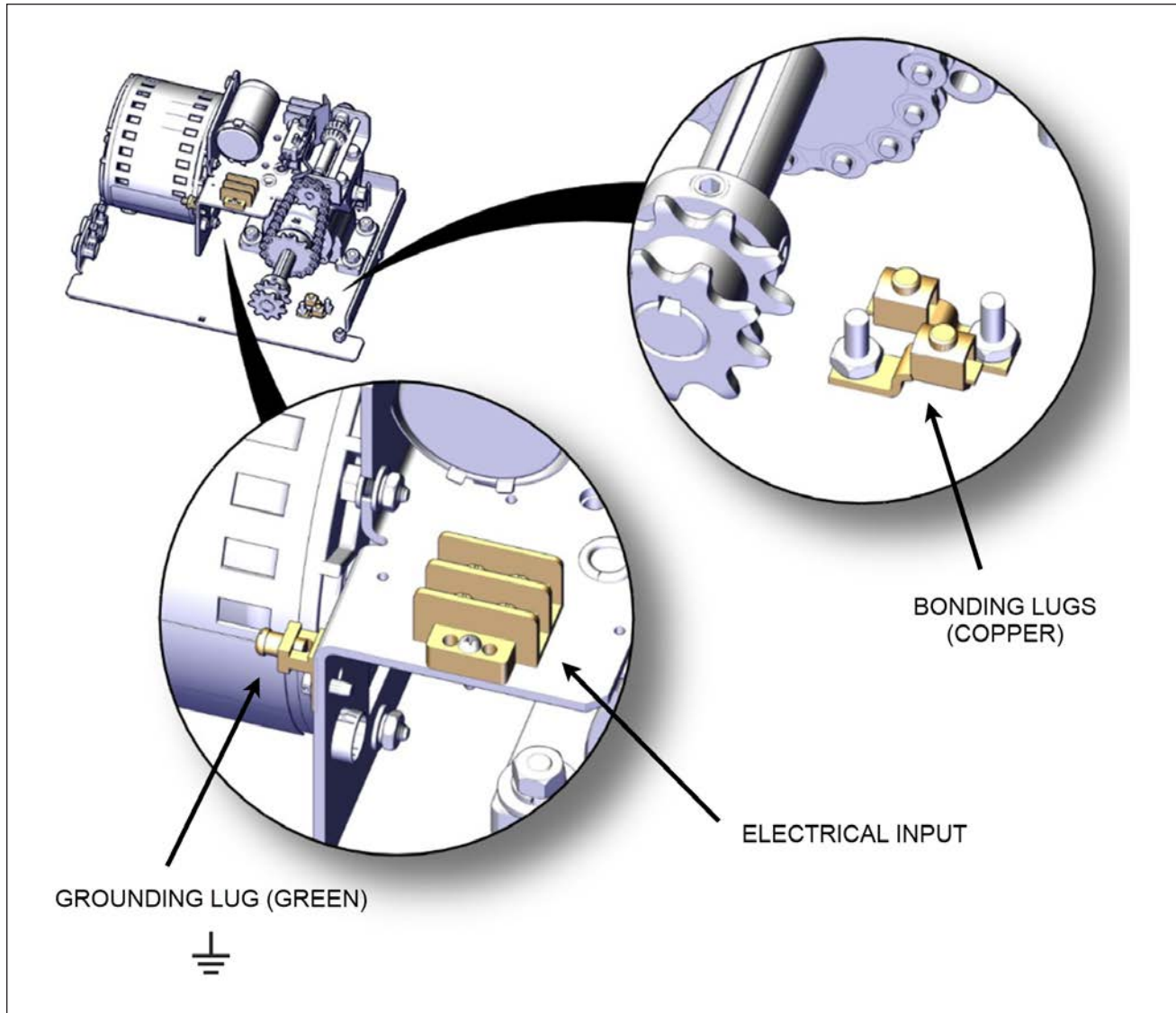

FIGURE 78: POWER SUPPLY CONNECTIONS

LIMIT SWITCH ADJUSTMENT



WARNING

Disconnect or turn off the power supply before starting any work on the cover. All electrical work should be performed by a qualified electrician.

NOTE

The up and down limit switches have been factory-adjusted and there should be no need to readjust them. If adjustments are required to ensure the cover does not come in contact with surrounding obstacles while being raised, the maximum height may be reduced. Never change the factory setting of the down limit nor increase the up limit beyond the factory setting. Failing to do so may result in equipment damage and/or injury.

1. Disconnect or turn off the power and lock out the power source.
2. Remove the four slotted screws at the bottom of the operator and remove the cover [Figure 79](#).

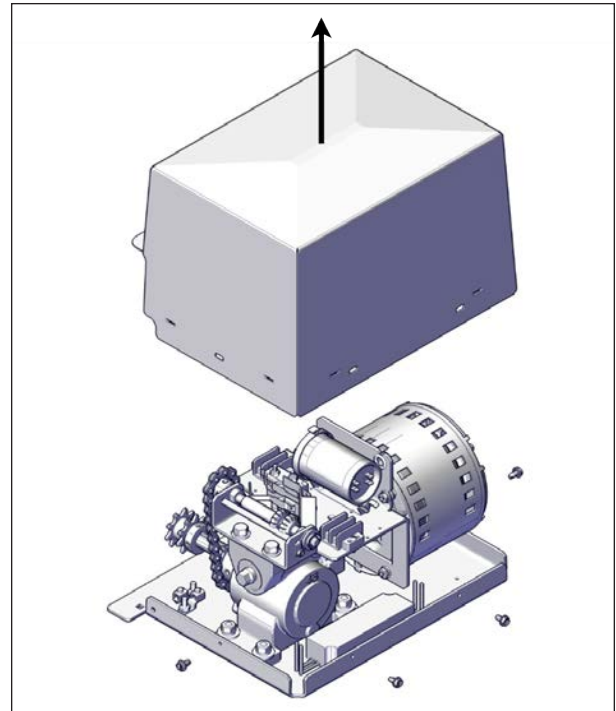

FIGURE 79: REMOVE OPERATOR COVER

3. Remove the slotted retaining screw and slide the cam plate out from operator frame see [Figure 80](#). Be careful not to rotate the cam wheels.

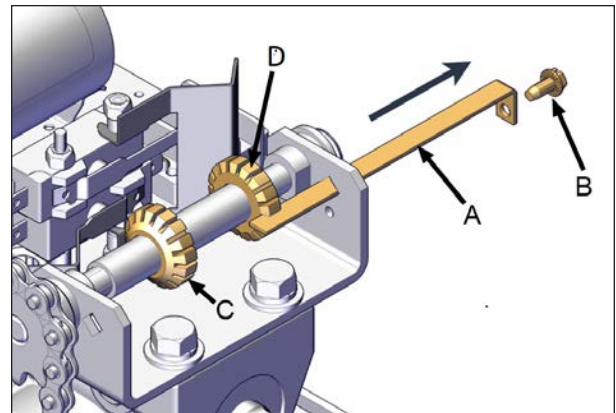

FIGURE 80: CAM PLATE REMOVAL

ID	DESCRIPTION
A	CAM PLATE
B	SLOTTED SCREW
C	DOWN-CAM WHEEL
D	UP-CAM WHEEL

4. To reduce the lift up limit, turn by hand the up-cam wheel counterclockwise looking from the cam plate mounting screw side as shown in [Figure 81](#). It has around 4° between each cam wheel tooth and adding or removing a tooth resolves in adding or removing approximately $5/32$ in. (4 mm) on the cover lifting stroke.

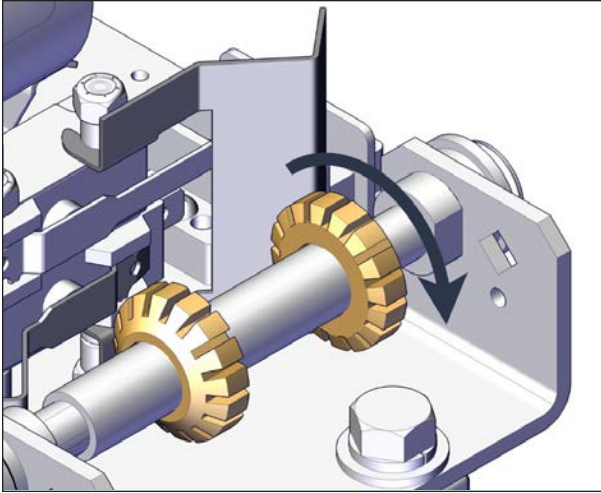

FIGURE 81: CAM WHEELS

5. Once the up limit is set to the desired position, reinstall the cam plate to its original location and make sure that it is properly inserted in the slot of each cam. Never operate the system without the cam plate and retaining screw installed.
6. Reinsert the slotted mounting screw.
7. Reinstall the operator cover without screws.
8. Turn the power on and test the system. Repeat the previous steps if necessary.
9. Once the adjustment is completed, fasten the operator cover with the screws (4).

INSTALLATION CHECKLIST (CUSTOMER COPY)

To ensure proper installation you must carefully read this checklist and confirm that you have completed all steps of the installation. The customer must receive a completed copy of this checklist.

(Please check each circle when the point is completed)

- The base preparation steps are done correctly (**Location and Foundation preparation sections**).
- The installation steps are done correctly (**Unpacking, Cover assembly, Lifting mechanism and Electrical connections sections**).
- The seal is properly installed and there is no steam leaking out around the cover. (**Seal application section**)
- The key switch is **permanently installed** at least 5 ft (1.5 m) away from the spa and 5 ft (1.5 m) from the ground.
- The electrical portion of the installation was done by a certified electrician (**Electrical connections, Limit switch adjustment sections**).
- All parts supplied and included into the crate are installed.
- The start-up procedure is completed (**The key sequence responds correctly and Testing the cover section is completed**).
- The all-weather seal works properly (**The cover raises and lowers properly**).
- The middle sleeves slide freely (**Manually slide the middle sleeve up and down when the cover is half open**).

Serial number: _____

Installer name: _____ Signature: _____

Customer name: _____ Signature: _____

Customer address: _____

Date (YYYY/MM/DD): _____

Dealer name : _____

INSTALLATION CHECKLIST (INSTALLER COPY)

To ensure proper installation you must carefully read this checklist and confirm that you have completed all steps of the installation. The customer must receive a completed copy of this checklist.

(Please check each circle when the point is completed)

- The base preparation steps are done correctly (**Location and Foundation preparation sections**).
- The installation steps are done correctly (**Unpacking, Cover assembly, Lifting mechanism and Electrical connections sections**).
- The seal is properly installed and there is no steam leaking out around the cover (**Seal application section**).
- The key switch is **permanently installed** at least 5 ft (1.5 m) away from the spa and 5 ft (1.5 m) from the ground.
- The electrical portion of the installation was done by a certified electrician (**Electrical connections, Limit switch adjustment sections**).
- All parts supplied and included into the crate are installed.
- The start-up procedure is completed (**The key sequence responds correctly and Testing the cover section is completed**).
- The all-weather seal works properly (**The cover raises and lowers properly**).
- The middle sleeves slide freely (**Manually slide the middle sleeve up and down when the cover is half open**).

Serial number: _____

Installer name: _____ Signature: _____

Customer name: _____ Signature: _____

Customer address: _____

Date (YYYY/MM/DD): _____

Dealer name : _____

OPERATE THE COVER

Please read the [SAFETY](#) section of this manual carefully before operating the cover.

RAISING/LOWERING THE COVER WITH THE KEY SWITCH

1. Make sure all debris and snow are removed from the top of the cover before operating.
2. Make sure there is nobody in the spa or near the spa when raising or lowering the cover.
3. Make sure there is no obstruction over or around the cover.
4. When raising or lowering the cover, hold the key until fully open or closed.
5. The cover will automatically stop in both the fully open and fully closed position.
6. Turn the key clockwise to raise the cover.
7. Turn the key counterclockwise to lower the cover.
8. The key automatically returns to center position when released (off position).
9. Always remove the key when the raising or lowering operations are completed and keep it in a safe location.

WARNING

Users must bring the key in the spa with them to prevent any unauthorized operation of the cover.

10. Install the rubber cap back on the key switch after each use.

IMPORTANT NOTE

Keep the spa cover fully closed when it is not used.

LED LIGHT KIT (OPTIONAL)

To operate the Covana light system, press on the light switch located under the cover on one of its corners. The Covana lights can operate in two different modes. You can select the mode by switching the lights off and immediately back on.

The Covana light system has two sequenced modes:

- Color locked
- Color wheel

NOTE

Always turn the lights off when not in use.



FIGURE 82: COVANA LIGHT SYSTEM

MANUAL OPERATION OF THE COVER

ELECTRICAL WARNING

Disconnect or turn off and secure all power supplies before starting any intervention on the cover.

1. Disconnect or turn off and secure the power supply.
2. Remove the screws at the bottom of the operator cover (4) and remove the cover as shown in [Figure 83](#).

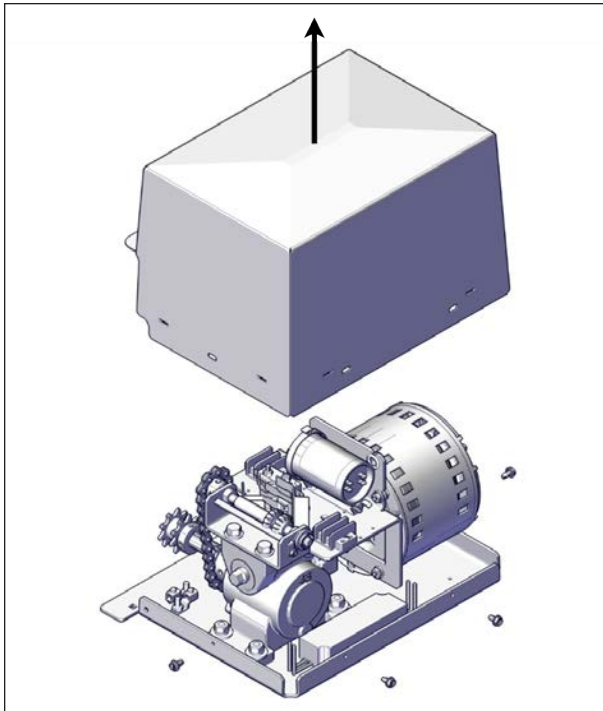

FIGURE 83: OPERATOR COVER REMOVAL

3. Use ½ in. (13 mm) hexagonal socket wrench to raise or lower the spa cover by turning the operator extension shaft see [Figure 84](#).
4. Slowly turn the extension shaft. Stop immediately if some tension occurs.

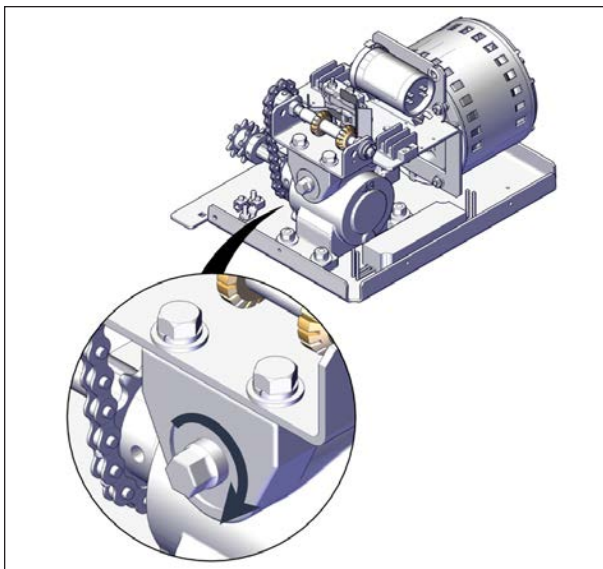

FIGURE 84: OPERATOR EXTENSION SHAFT



WARNING

Never use a power tool, as this will damage the unit.

5. Turn the extension shaft clockwise to lower the cover and counterclockwise to raise the cover.



WARNING

Do not exceed the limits of the mechanism. Failure to respect this guideline may cause mechanical failure.

6. Reinstall the operator cover with the four screws.
7. Reconnect and turn on the power supply.

WIRE GUARD REASSEMBLY

You might need to reassemble your wire guard harness if the magnetic plate ([Figure 85](#)) came off to let the wire out.

- The function of the wire guard is to protect the wire from excessive strain. The main causes for the magnetic plate to come off are the wire getting caught, ice buildup around the roof or someone catching or pulling on the wire.
- We recommend following the steps below for properly reassembling the wire guard.

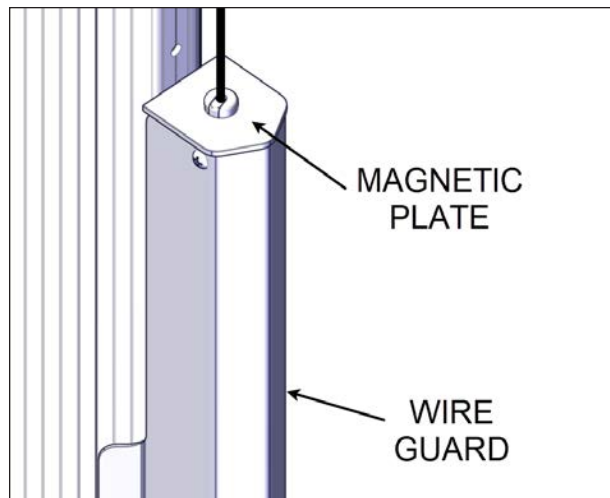

FIGURE 85: MAGNETIC PLATE AND WIRE GUARD



WARNING

Failure to follow these guidelines could impede designed performance or could cause mechanical failure.

1. Check if the wire has not been damaged (cuts in wire, disconnected etc.) see [Figure 86](#).

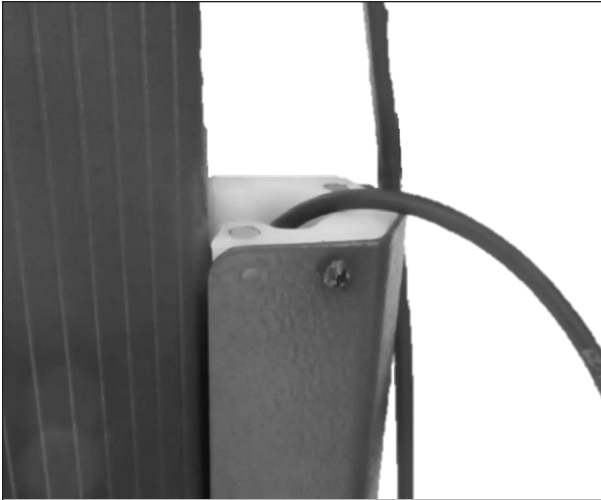

FIGURE 86: CHECK WIRE DAMAGE

2. Fold wire in two by making a loop with your hands. The length of the loop must be approximately 20" (50 cm) long see [Figure 87](#).

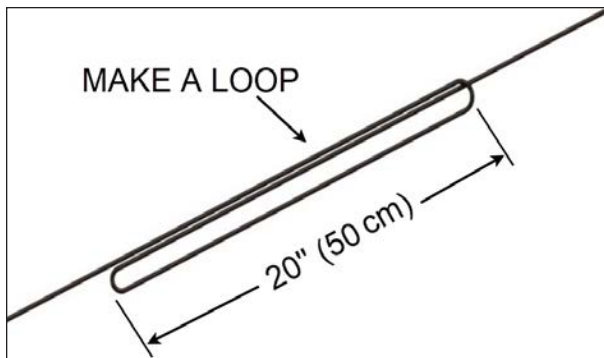

FIGURE 87: WIRE LOOP

3. While still holding the loop, thread the wire in the wire guard. All of the wire loop must be threaded into the wire guard see [Figure 88](#).



WARNING

Do not attempt to tape or fix the wire together by any means. The wire guard is designed to function as shown.

Ensure the wire is not caught in the post or twisted around any other object before proceeding.

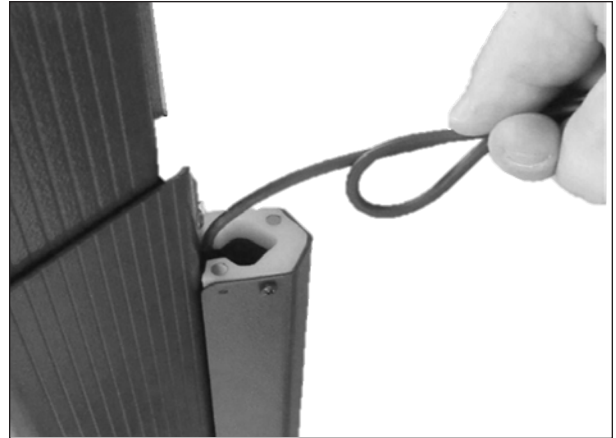

FIGURE 88: WIRE INSERTION INTO THE WIRE GUARD

4. Reinstall the plate on top of the wire guard. There are two magnets that hold the plate in place see [Figure 85](#). The wire should have sufficient tension and stand straight. Make sure the cable is not jammed into the wire guard or twisted around the post.
5. Once the plate is installed, the assembly should look as shown in [Figure 85](#). The wire should have sufficient tension and look straight.
6. Operate the cover by cycling it up and down. If the plate still comes off due to excessive tension, consult the Troubleshooting section or call your local Covana dealer.

ELECTRICAL DIAGRAMS

Next pages of this section show electrical diagrams of the cover.

WIRING DIAGRAM (NORTH AMERICA) – 60 HZ, 120 VAC OPERATOR

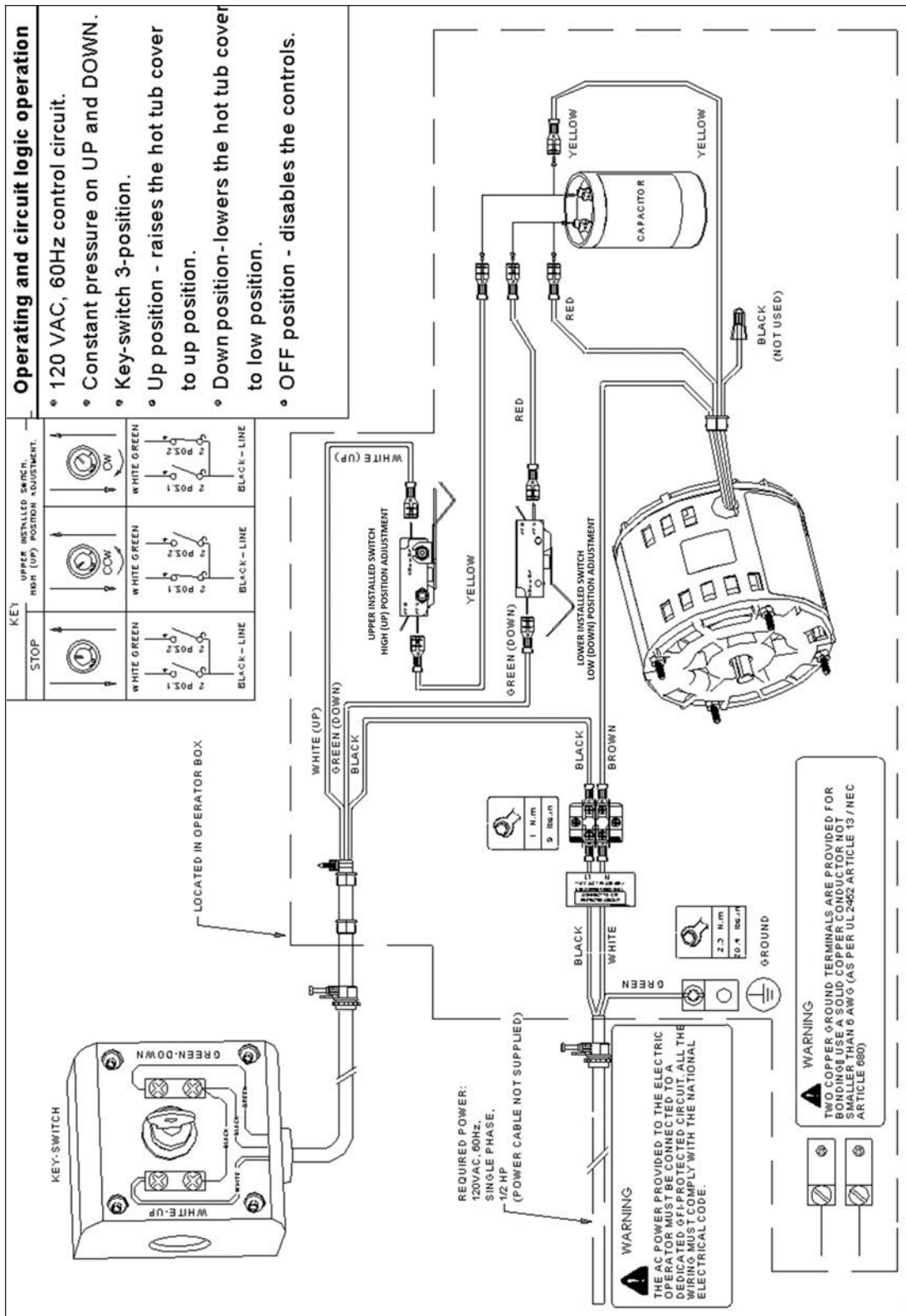

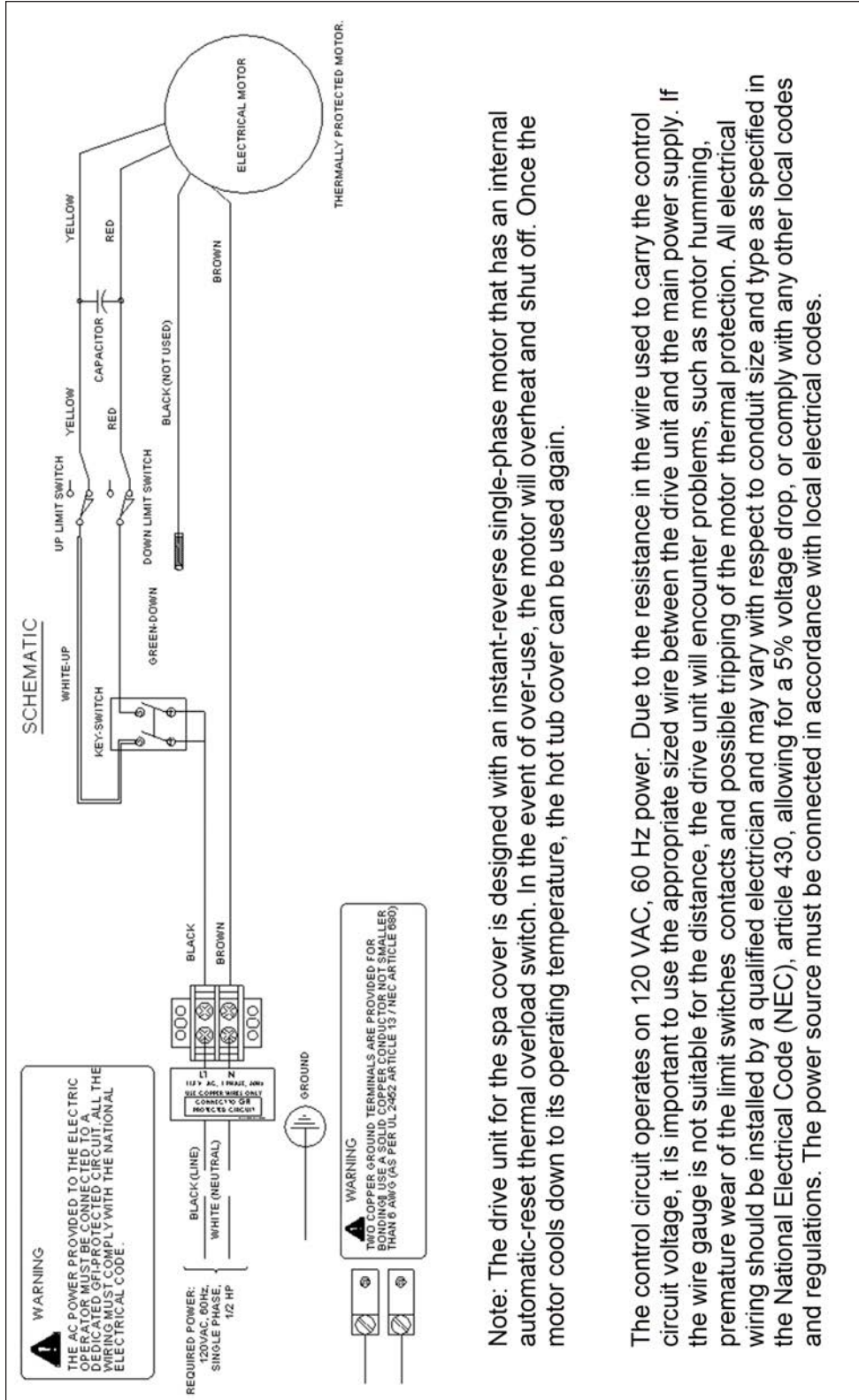

Note: The drive unit for the spa cover is designed with an instant-reverse single-phase motor that has an internal automatic-reset thermal overload switch. In the event of over-use, the motor will overheat and shut off. Once the motor cools down to its operating temperature, the hot tub cover can be used again.

The control circuit operates on 120 VAC, 60 Hz power. Due to the resistance in the wire used to carry the control circuit voltage, it is important to use the appropriate sized wire between the drive unit and the main power supply. If the wire gauge is not suitable for the distance, the drive unit will encounter problems, such as motor humming, premature wear of the limit switches contacts and possible tripping of the motor thermal protection. All electrical wiring should be installed by a qualified electrician and may vary with respect to conduit size and type as specified in the National Electrical Code (NEC), article 430, allowing for a 5% voltage drop, or comply with any other local codes and regulations. The power source must be connected in accordance with local electrical codes.

WIRING DIAGRAM (NORTH AMERICA) (LIGHTS)- 60 HZ, 120 VAC OPERATOR

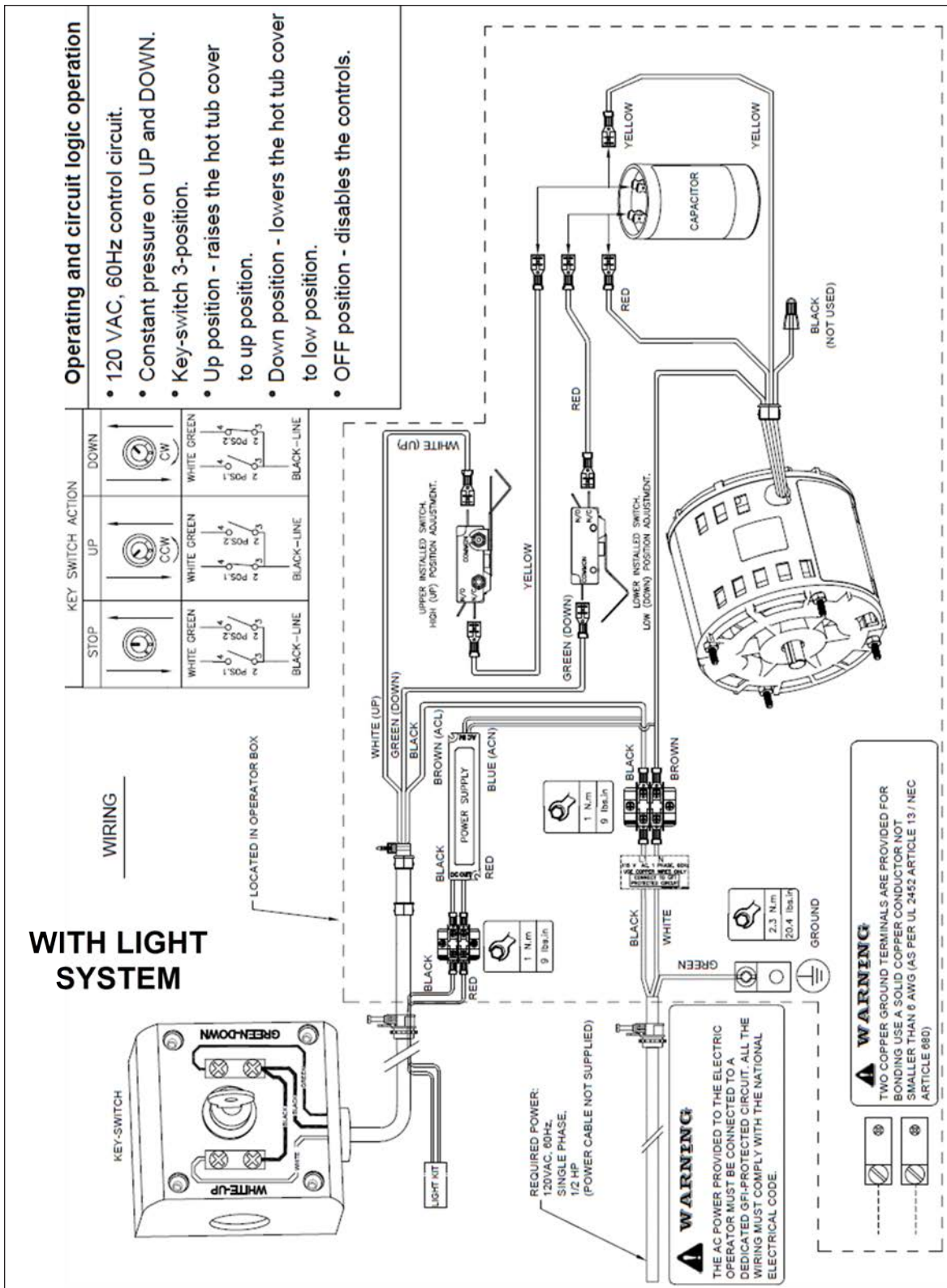

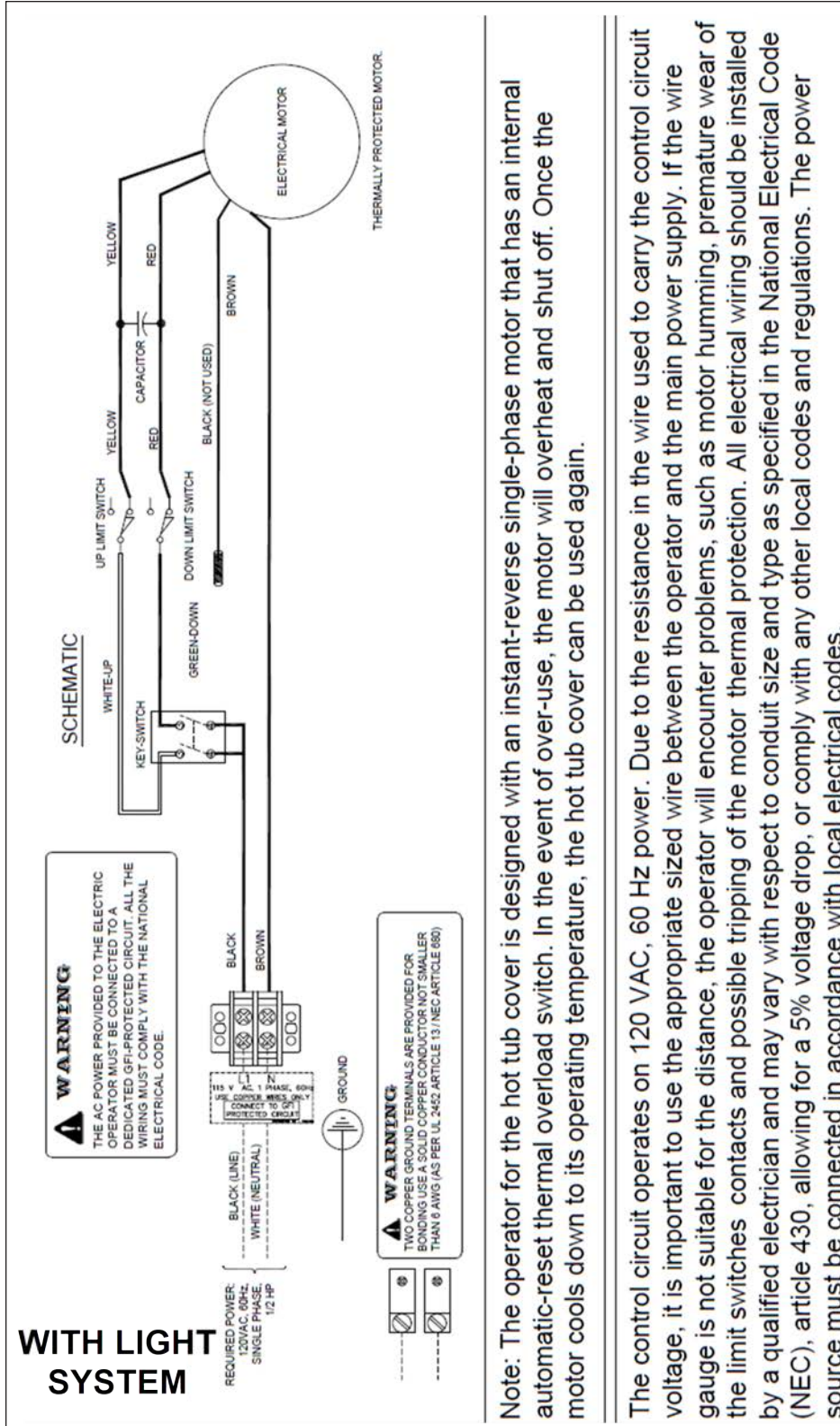

Note: The operator for the hot tub cover is designed with an instant-reverse single-phase motor that has an internal automatic-reset thermal overload switch. In the event of over-use, the motor will overheat and shut off. Once the motor cools down to its operating temperature, the hot tub cover can be used again.

The control circuit operates on 120 VAC, 60 Hz power. Due to the resistance in the wire used to carry the control circuit voltage, it is important to use the appropriate sized wire between the operator and the main power supply. If the wire gauge is not suitable for the distance, the operator will encounter problems, such as motor humming, premature wear of the limit switches contacts and possible tripping of the motor thermal protection. All electrical wiring should be installed by a qualified electrician and may vary with respect to conduit size and type as specified in the National Electrical Code (NEC), article 430, allowing for a 5% voltage drop, or comply with any other local codes and regulations. The power source must be connected in accordance with local electrical codes.

WIRING DIAGRAM (EUROPE) – 50 HZ, 230 VAC OPERATOR

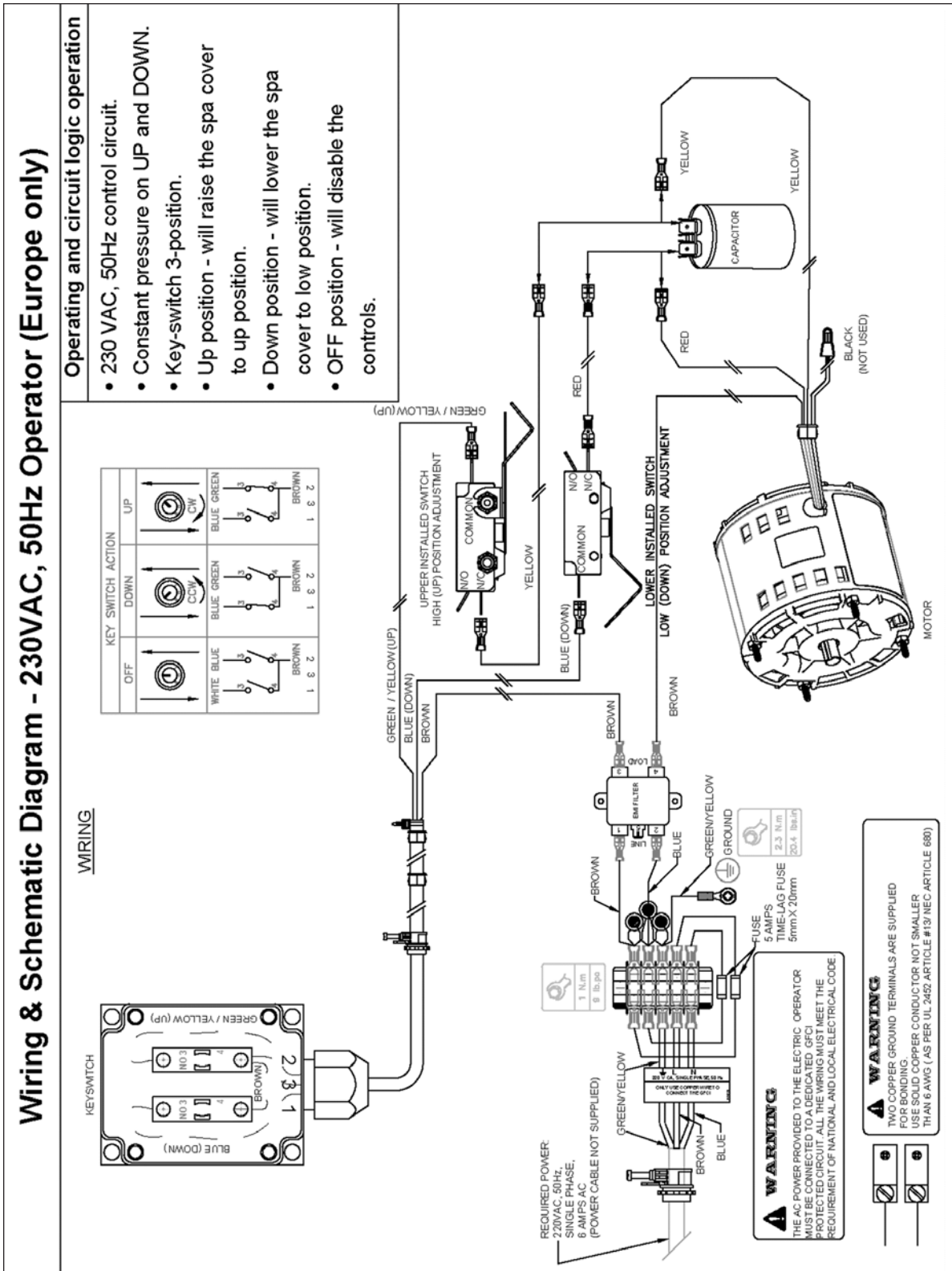

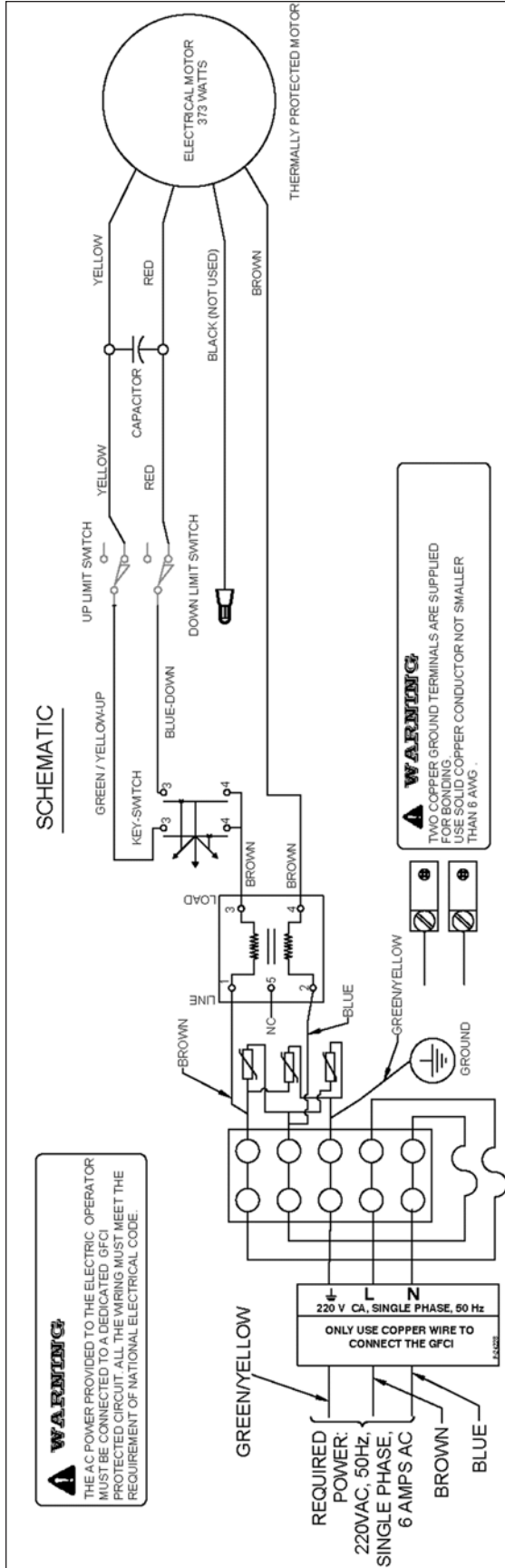

Note: The spa cover operator is designed with an instant reverse single-phase motor with internal automatic reset thermal overload. In case of over-use, the motor will overheat and shutdown. Once the motor cools down to its operational temperature, the spa cover can be used again.

The control circuit operates at 230 VAC, 50Hz. Due to the resistance in the wire used to carry the control circuit voltage, it is important to use the appropriate wire size between the operator and the main power supply. If the wire gage is not suitable for the distance, problems in operator will be encountered such as motor humming, premature wear of the limit switches contacts and possible tripping of the motor thermal protection. All power wiring should be installed by a qualified electrician and may vary with respect to conduit size and type as specified in the National Electrical Code (NEC), Article 430, allowing 5% volt drop, or comply to any other local codes and regulations. Power must be connected in accordance with local electricity codes.

Brevet en instance / Patent Pending
www.covana.com

P-24344-R4
C.A.: 200827

WIRING DIAGRAM (EUROPE) (LIGHTS)- 50 HZ, 230 VAC OPERATOR

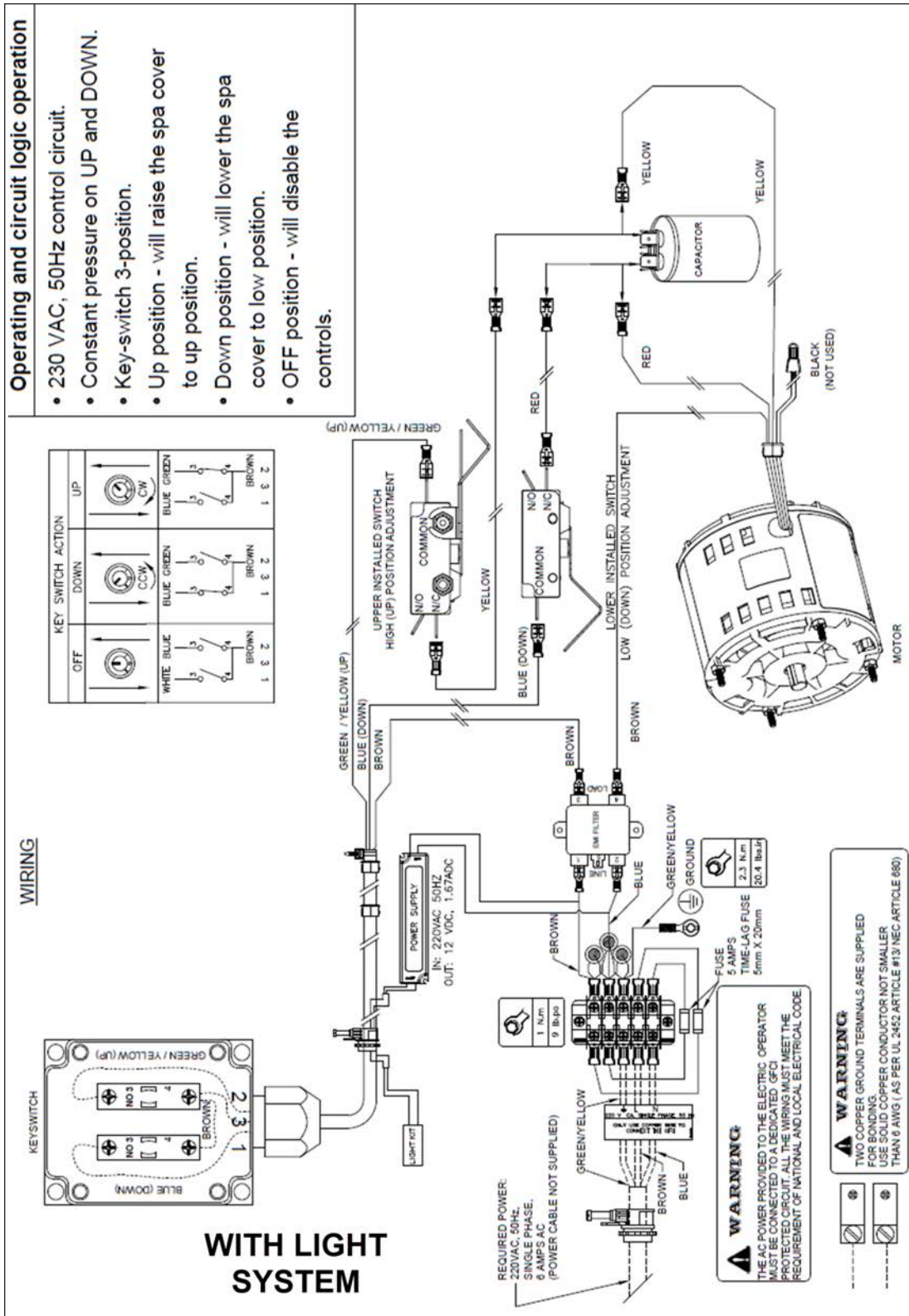

WITH LIGHT SYSTEM

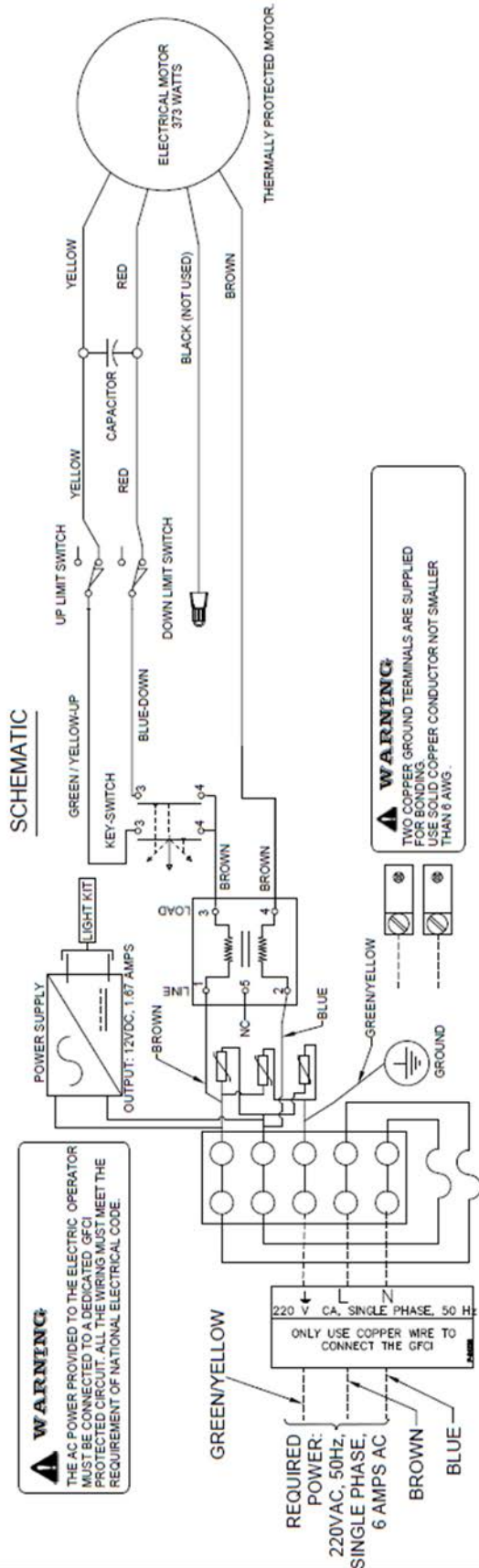

Note: The spa cover operator is designed with an instant reverse single-phase motor with internal automatic reset thermal overload. In case of over-use, the motor will overheat and shutdown. Once the motor cools down to its operational temperature, the spa cover can be used again.

The control circuit operates at 230 VAC, 50Hz. Due to the resistance in the wire used to carry the control circuit voltage, it is important to use the appropriate wire size between the operator and the main power supply. If wire gage is not suitable for the distance, problems in operator will be encountered such as motor humming, premature wear of the limit switches contacts and possible tripping of the motor thermal protection. All power wiring should be installed by a qualified electrician and may vary with respect to conduit size and type as specified in the National Electrical Code (NEC), Article 430, allowing 5% volt drop, or comply to any other local codes and regulations. Power must be connected in accordance with local electricity codes.

MAINTENANCE

The product lifetime depends on the time you spend for the care and maintenance of the cover.

WINTERIZING

If you plan on winterizing your swim spa during the cold season, Covana recommends winterizing the cover as well. This process prevents any potential damage to the cover and minimizes the risk of freezing water damage to the spa. Please follow these instructions:



WARNING

These instructions are relevant for anyone who plans to stop using the spa for a long period of time or especially if the temperature goes below the freezing point.

1. Clean the cover completely to remove any dust, greasy residue or any other dirt from all surfaces.
2. Prepare the spa for closure by following the spa manufacturer's winterization instructions.
3. Completely close the cover on the spa. Make sure the seal touches the whole perimeter of the spa.
4. Shut off the power of the cover. This can be done by either shutting off and securing the circuit breaker powering the cover.
5. Install a waterproof canvas over the cover. Make sure to follow the spa manufacturer's guidelines during this step.
6. Install a waterproof and watertight protection canvas over the operator.



WARNING

Using any type of fabric or plastic canvas to cover the Covana cover during hot weather may damage the components. Only use such protection for the winterization procedure and during the cold season.

Remove any type of cover or plastic canvas as soon as seasonal temperatures are higher than the freezing point.

7. For regions with a long seasonal snowfall, remove excessive snow accumulation regularly or after a heavy snowfall to avoid damage to the structure of the cover. Do not let more than 12 in. (30 cm) of snow accumulate on the cover.

WASHING THE COVER

Washing the cover is an essential part to maintain and keep it in the best running conditions. Clean your cover as needed or when dirt, debris or leaves are present. We also recommend cleaning your cover before and after winterization.

TOOLS AND PRODUCT TO USE

- Use a 1% solution of household dish soap. The cleaner is required to have a neutral pH (pH range 6.5-7.5).
- Soft plastic brush
- Sponge
- Cloth

The following steps are guidelines to safely and properly clean the cover:

METHOD:

1. Rinse the cover with water in order to remove any large accumulated debris.
2. Apply the soap solution, working it across the surface in a scrubbing or circular motion. The surface of the cover panels can be cleaned with a sponge, cloth or a soft plastic brush.

3. Quickly rinse very thoroughly to remove all traces of soap; otherwise, a film will build up giving the panel a dull, dirty appearance.



WARNING

Never use a pressure washer or high pressure to clean the cover. The high pressure could puncture the fiberglass roof.

Never use harsh detergents that may cause a chemical reaction and permanently damage the surface.

Do not use abrasive cleaners.

Do not use a cleaner or stain remover that contains chlorinated hydrocarbons or aromatic hydrocarbons.

POST GREASING

This unit will require the following greasing maintenance to ensure the best performance.

The internal jacks require yearly greasing. Early in the fall season is the best time. The “Mobil Epic EP MOLY Grease” is recommended for cold and hot climates. Ideally, a sprayable grease or an equivalent low temperature synthetic grease.

NOTE

The posts will not lift by unscrewing the post covers. Only the motor can raise or lower the posts.

POST GREASING PROCEDURE

1. Lower the roof until it is fully closed.
2. Remove rubber cap on top of each post see [Figure 89](#).

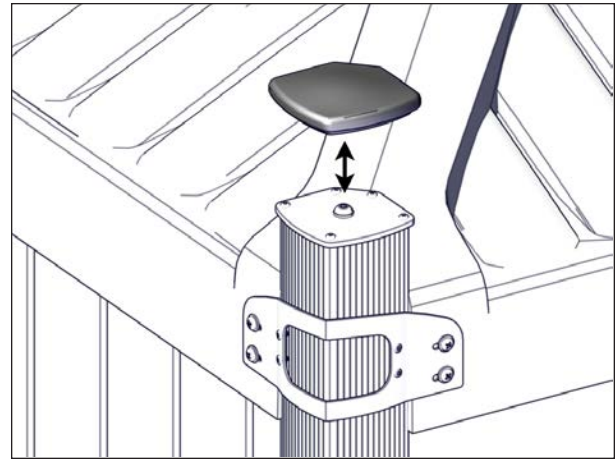

FIGURE 89: RUBBER CAP REMOVAL

3. Dismount the screws (5) on the top plate of the posts, see [Figure 90](#).
4. Remove the center screw. Keep the top plates and the screws in a safe location see [Figure 90](#).

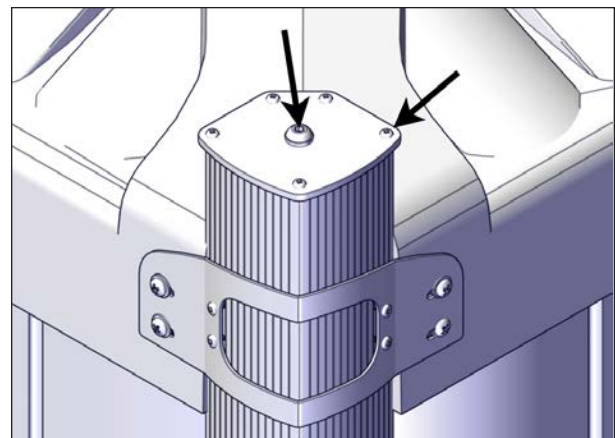

FIGURE 90: SCREW REMOVAL

5. Repeat previous steps for all posts.



WARNING

Failure to remove all four top plates will result in important damages to your cover.

Do not use power tools, since screws might break or strip.

6. Raise the jacks with the key switch. The four internal jacks will raise but the cover panels should stay in place, see [Figure 91](#).

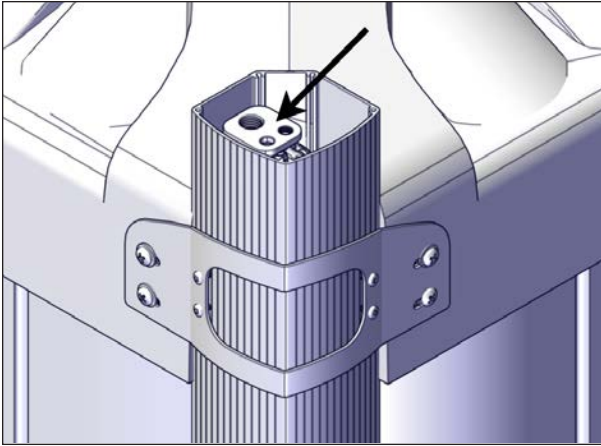

FIGURE 91: INTERNAL JACK

7. Raise the jacks until they reach the maximum height see [Figure 92](#).

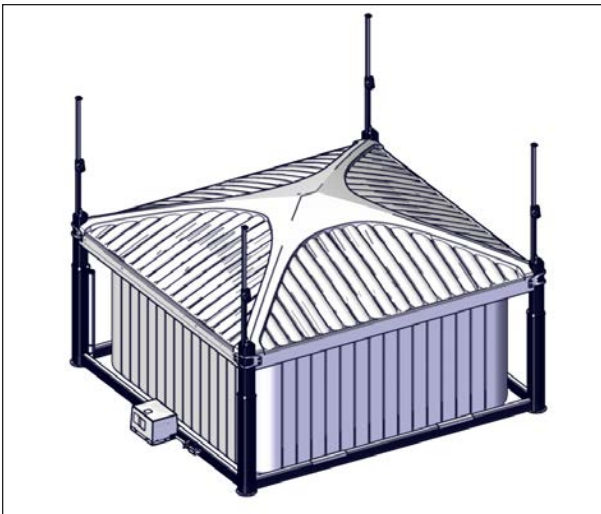

FIGURE 92: JACKS RAISING

8. Spray grease on all the sliding parts and mechanical components for all four jacks see [Figure 93](#).

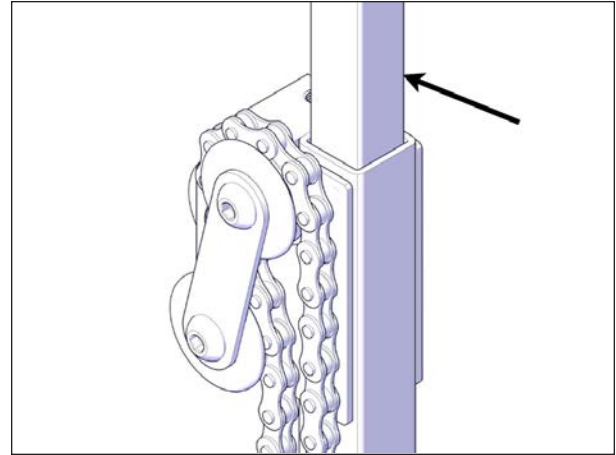

FIGURE 93: SLIDING PARTS GREASING

9. Inspect the chains for signs of deterioration. If this is the case, please call your local Covana dealer immediately see [Figure 94](#).

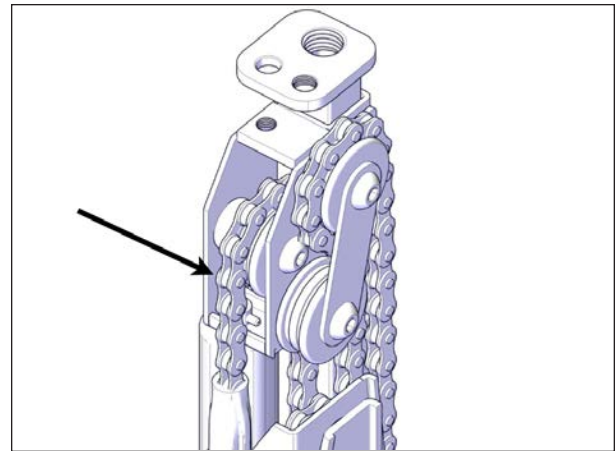

FIGURE 94: JACK CHAINS

10. Cycle the system up and down and inspect if any further grease should be added.
11. Lower the system completely until it stops automatically.
12. Reinstall the top plates with all five screws and the hexagonal head screw on the top plate of the post.



WARNING

Never use a power tool. It may break the screws.

13. Reinstall the rubber cap on top of the post.
14. Repeat previous steps for all posts.

CHAIN LUBRICATION

This procedure shows how to lubricate the transmission power chain attached to the operator. The “Mobil Epic EP MOLY Grease” is recommended for cold and hot climates. Ideally, a sprayable grease or an equivalent low temperature synthetic grease.

NOTE

Two separate chains are attached to the operator (left and right). Do not remove the U-Frame protecting the chains.

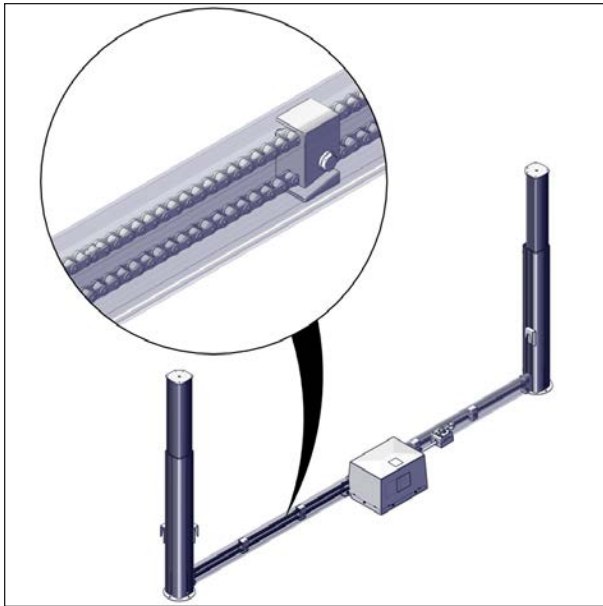

FIGURE 95: POWER TRANSMISSION CHAIN

PROCEDURE

1. Remove the lower sleeve screw. The screw is visible when facing the post see [Figure 96](#).

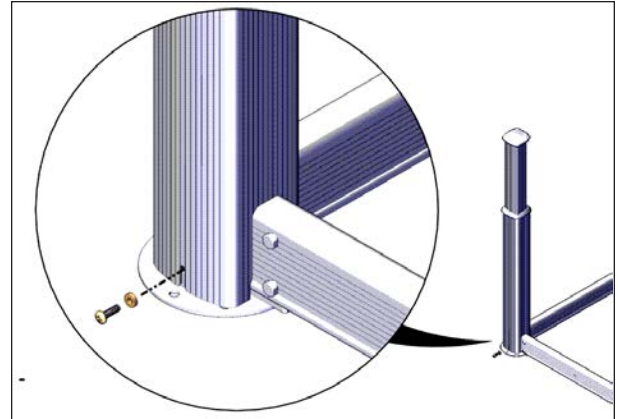

FIGURE 96: SLEEVE BOTTOM SCREW

2. Lift up by hand the sleeve and keep it safely in position with a wooden block.

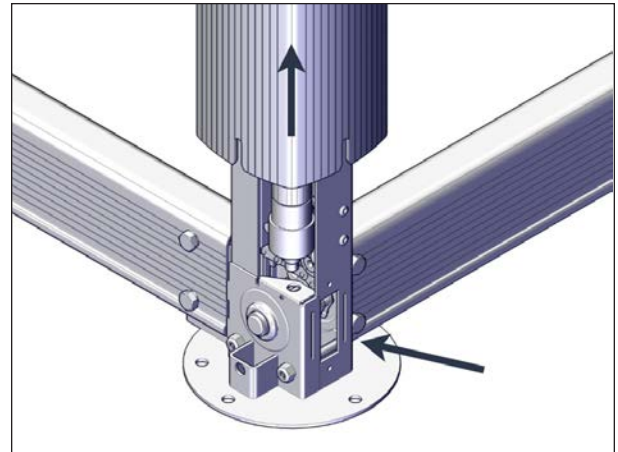

FIGURE 97: ACCESS TO THE CHAINS



CAUTION

If sleeve drops down, it might cause some damage.

3. Locate the chain inside the post. The opening at the bottom of the post allows access to the chain.
4. Spray the chain lightly with grease while another operator cycles the cover up and down with the key switch.
5. Lower the sleeve. Make sure the nylon washer is outside of the sleeve. Reinstall the screw at the bottom of the sleeve.
6. Repeat previous steps with the opposite post.

PERIODIC MAINTENANCE TABLE

TASKS	FREQUENCY				
	EACH USE	WEEKLY	EVERY 3 MONTHS	YEARLY	AS NEEDED
Perform a visual inspection (debris, snow, ice, etc.).	X				
Check that the sleeves are correctly positioned. (Middle sleeves are not out of their normal position).	X				
Verify if all-weather seals are correctly positioned (in contact with the outer sleeves when the cover is closed).	X				
Listen to any unusual noises during operation.	X				
Verify the seal around the cover (no vapor steam leakage).		X			
Verify the lifting mechanism by raising and lowering the cover.		X			
Verify the anchoring of the cover.		X			
Test the GFCI.			X		
Check the tension of the chains on all posts and in the U-frame. *				X	
Lubricate chains on all posts and in the U-frame. *				X	
Grease the jack assemblies. *				X	
Wash the cover with a mild detergent (i.e., dishwashing detergent) and water. Rinse well using only water.					X

*Contact your local Covana dealer

Please call your Covana dealer for any mechanical, electrical or aesthetic maintenance.

TECHNICAL SPECIFICATIONS

COVANA COVER FRONT VIEW

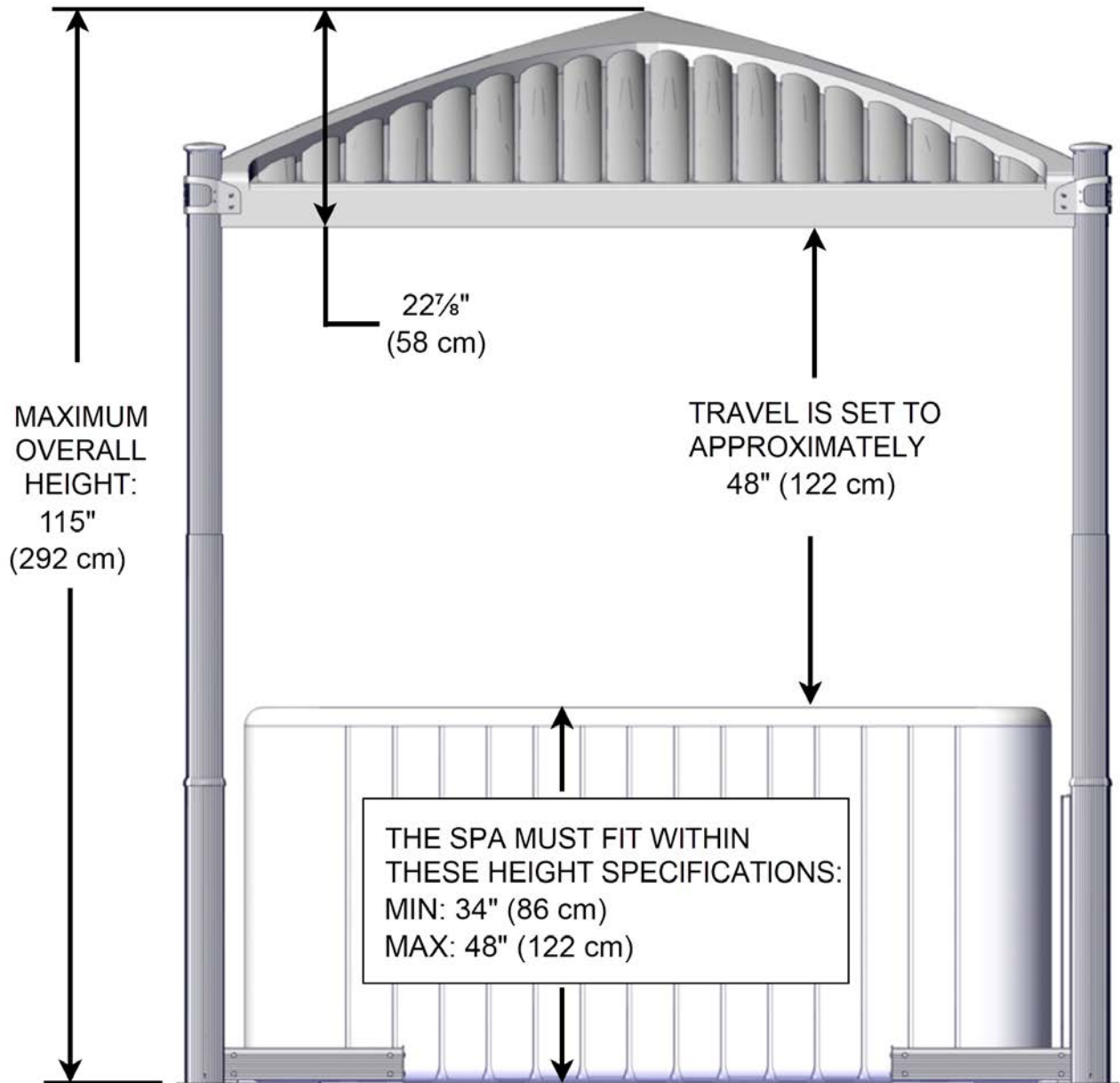

FRAME DIMENSIONS AND FOOT PRINT

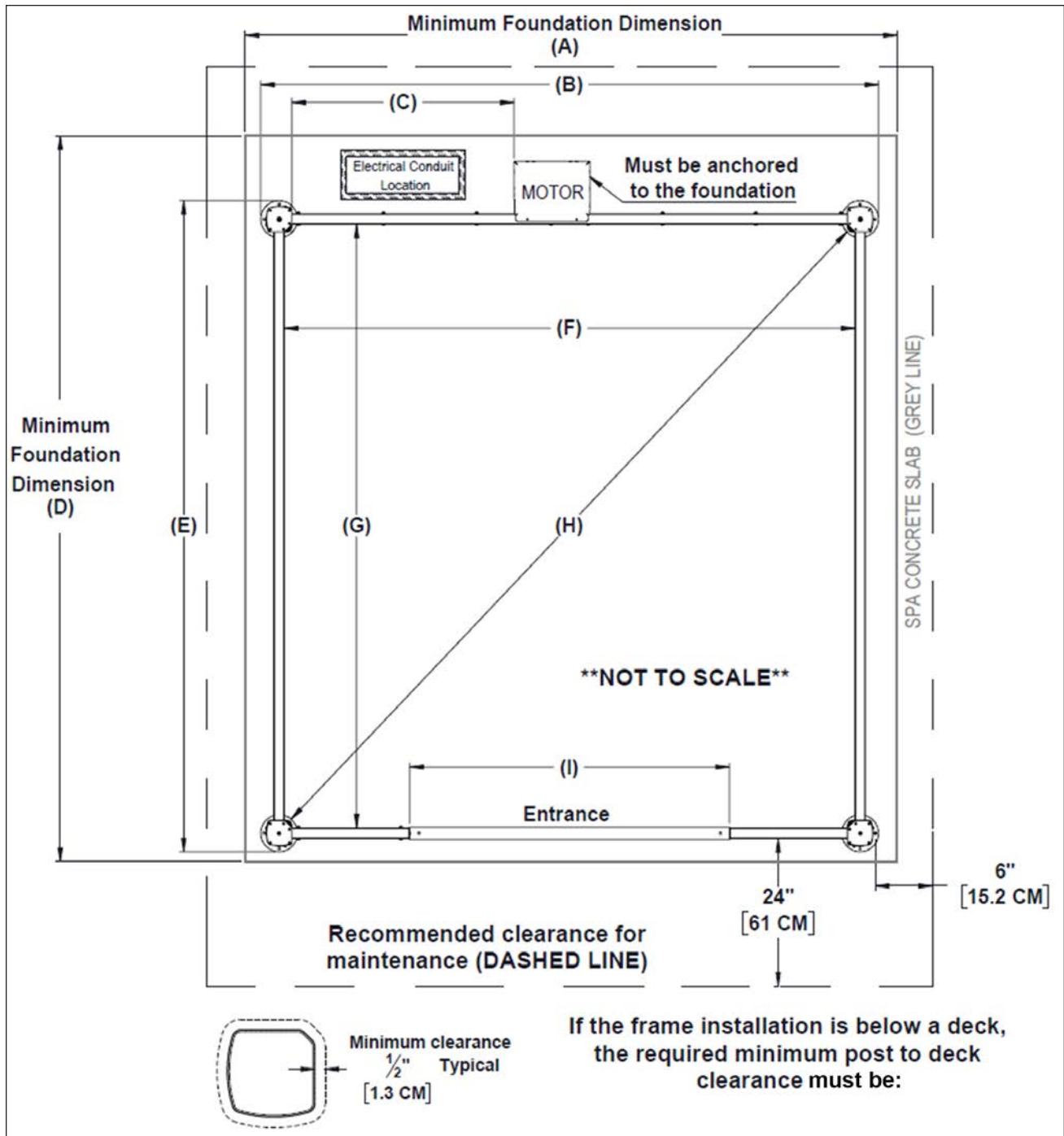

INCH (mm)	A	B	C	D	E	F	G	H	I
STANDARD MODEL	106 (2692)	100.5 (2553)	35 (889)	118 (2297)	105.75 (2685)	92.75 (2356)	98 (2489)	130.75 (3321)	52 (1321)
LONG SIDE MODEL	112 (2845)	105.75 (2685)	39 (991)	113 (2870)	100.5 (2553)	98 (2489)	92.75 (2356)	130.75 (3321)	57 (1448)

CONCRETE SLAB LAYOUT OPTION

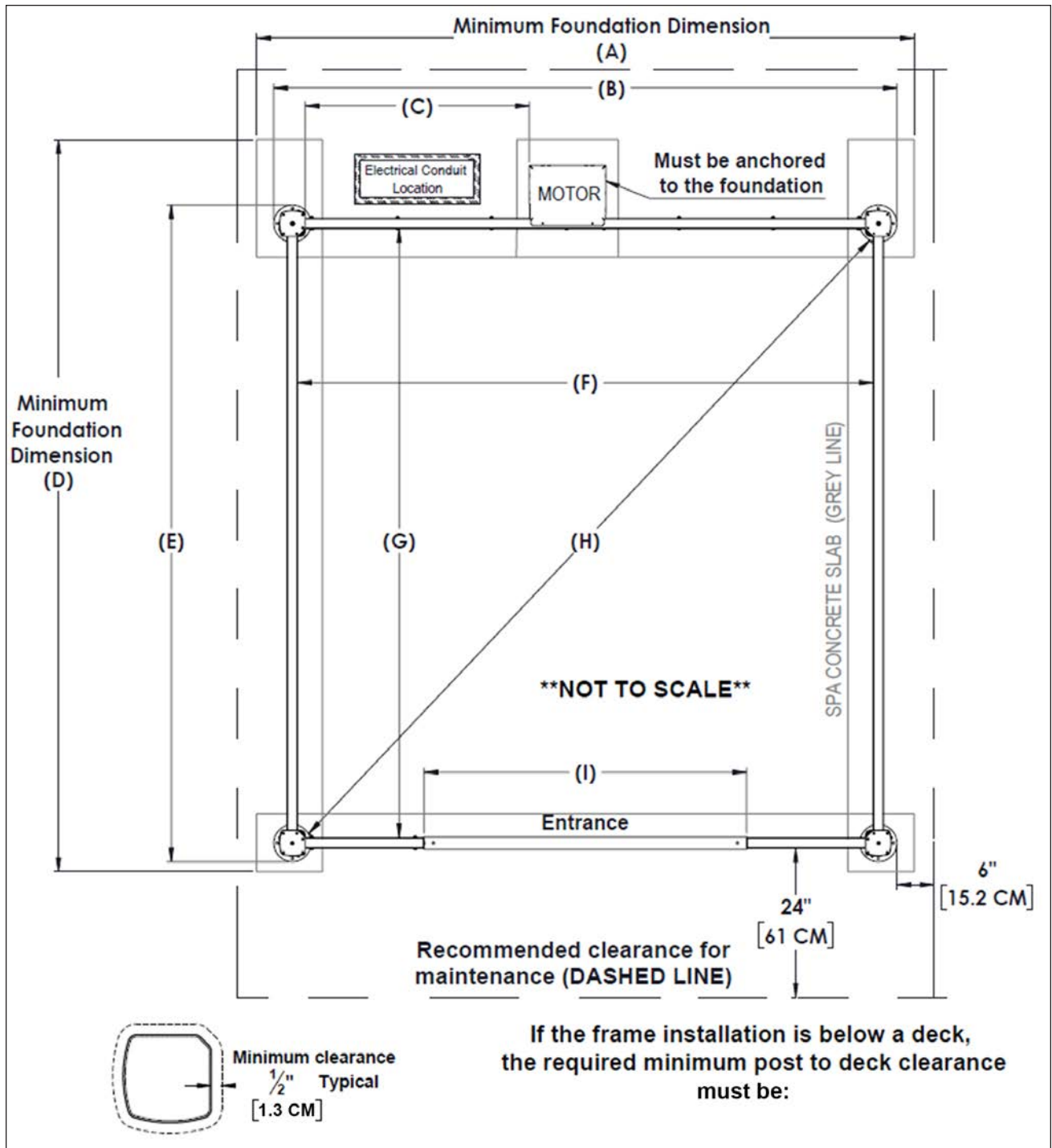

INCH (mm)	A	B	C	D	E	F	G	H	I
STANDARD MODEL	106 (2692)	100.5 (2553)	35 (889)	118 (2297)	105.75 (2685)	92.75 (2356)	98 (2489)	130.75 (3321)	52 (1321)

INCH (mm)	A	B	C	D	E	F	G	H	I
LONG SIDE	112	105.75	39	113	100.5	98	92.75	130.75	57
MODEL	(2845)	(2685)	(991)	(2870)	(2553)	(2489)	(2356)	(3321)	(1448)

ELECTRICAL SPECIFICATIONS

The cover requires a dedicated single phase 115 VAC (North America) or 230 VAC (Europe) hard-wired power supply.

The cover must be installed in accordance with and comply with all applicable local codes and regulations. All wiring and connections should be performed by a certified electrician.

Wires and cables should be sized according to local codes and regulations.

NORTH AMERICAN REQUIREMENTS

Voltage	115 V, 60 Hz (1 hot, 1 neutral, 1 ground)
GFCI	15 A single-pole GFCI (not included)
Current draw	Max 12 A

EUROPEAN REQUIREMENTS

Voltage	230 V, 50 Hz (2, 1 ground)
GFCI	10 A single-pole GFCI (not included)
Current draw	Max 6 A



WARNING

Covana does not allow any modifications to the electrical system. Covana reserves the right to void the warranty if any modification is done without its approval.

OPERATION LIMITATIONS



WARNING

The cover should never be used if the following conditions are reached.

Maximum wind	Gusts of 30 mph (50 km/h) while in the raised position and 45 mph (70 km/h) when completely lowered on the spa.
Maximum weight on the cover (evenly distributed)	200 lb. (90 kg)

GENERAL SPECIFICATIONS

Lifting speed	2.5 in./s (6 cm/s)
Total weight	Up to 600 lb. (272 kg)
Length of key switch cable	25 ft (7.6 m)

TROUBLESHOOTING

PROBLEM	PROBABLE CAUSES	SOLUTIONS
The cover does not raise or lower (Silent motor and no movement)	<ul style="list-style-type: none"> The GFCI is tripped. The power source is disconnected. 	<ul style="list-style-type: none"> Reset the GFCI. Verify that the power source is enabled. Check the breaker panel. Verify whether the cables were damaged or pinched.
The cover does not raise or lower. (Motor humming and some visible movement)	<ul style="list-style-type: none"> Posts are frozen. Jack assemblies are jammed. The motor is obstructed. Posts are obstructed. The debris on the cover is too heavy. 	<ul style="list-style-type: none"> Remove all the debris from the top of the cover. Verify whether any posts are obstructed. Use methanol to free ice buildup on posts. Apply grease on the post assemblies. Verify the relative position of the four posts (See Foundation Preparation section). Call your Local authorized Covana dealer.
The posts are not equally positioned.	<ul style="list-style-type: none"> The post screws (attached to the outer shell) are loose. The chain skipped during operation. A spring pin at the bottom of a jack is broken. A drive shaft has fallen off. Excessive weight on one side of the cover. 	<ul style="list-style-type: none"> Lower the cover completely and fasten the post back in at the correct height. Verify whether a drive shaft has fallen off and if it is the case, reinstall the shaft. Lower the cover and replace the chain. Replace any missing or broken spring pin by lifting the outer sleeve, using an awl and a hammer.. Remove all debris from the top of the cover. If all previous attempts failed, contact your local authorized Covana dealer.
The shades are loose, retract improperly and/ or disconnect from the brackets. The shades are wrinkling or bulging at the roller.	<ul style="list-style-type: none"> The internal spring is not wound enough. Too much tension in the internal spring. Holding bracket not parallels. 	<ul style="list-style-type: none"> Consult shade installation manual. Remove the bottom bar and reset the tension back to "4 turns". Make sure the outer sleeves are sitting on the foot plate, reposition the holding bracket so the roller shade is moving straight.

PROBLEM	PROBABLE CAUSES	SOLUTIONS
The middle sleeve has gripped and might have dropped abruptly	<ul style="list-style-type: none"> • Posts are frozen. • The stopper kit is broken/missing. 	<ul style="list-style-type: none"> • Verify the position of the all-weather seal. While cover is closed, it must be sitting on the top of the outer sleeve. • Check whether the stopper kit is broken/missing. • Reinstall the sleeves. • Check level on 2 faces of the sleeve. • If all previous attempts failed, contact your local authorized Covana dealer.
The cover raises unevenly.	<ul style="list-style-type: none"> • The chain is broken. • A spring pin is broken. • A drive shaft has fallen off. • Posts are gripped. 	<ul style="list-style-type: none"> • Call your local certified Covana dealer for technical support. • Do not operate the cover.
Cover raises but does not lower.	<ul style="list-style-type: none"> • The cam plate is incorrectly positioned or missing. • The key switch is faulty. • Limit switches cannot move properly. 	<ul style="list-style-type: none"> • Remove power before performing any electrical work. • Ask a certified electrician only. Open the operator and check for faulty up and down limit switches. • Check if there is any corrosion on the terminals and clean it if necessary. • Open the key switch and check for faulty switch. • Check if any electrical cables are damaged or pinched.
Cover lowers but does not raise.	<ul style="list-style-type: none"> • The cam plate is incorrectly positioned or missing. • The key switch is faulty. • Limit switches cannot move properly. 	<ul style="list-style-type: none"> • Remove power before performing any electrical work. • Ask a certified electrician only. Open the operator and check for faulty up and down limit switches. • Check if there is any corrosion on the terminals and clean it if necessary. • Open the key switch and check for faulty switch. • Check if any electrical cables are damaged or pinched.

PROBLEM	PROBABLE CAUSES	SOLUTIONS
Cover seal turned black.	<ul style="list-style-type: none"> • The seal has accumulated mold. 	<ul style="list-style-type: none"> • Clean the affected areas with bleach and a soft brush. Rinse well with water.
Lights do not work.	<ul style="list-style-type: none"> • The lighting assembly is faulty. • The light switch is faulty. 	<ul style="list-style-type: none"> • Check if the power source is enabled. • Replace the light switch. • If all previous attempts failed, contact your local authorized Covana dealer.
Magnetic plate is not holding in place.	<ul style="list-style-type: none"> • Excessive tension in the Constant Tension System (CTS 70). • CTS 70 is stuck in place. 	<ul style="list-style-type: none"> • Lift the side of the outer shell where the cable exits from the inner shell; remove the CTS 70 from the steel frame and grease the interior surfaces. • Check that the CTS 70 pulley carrier can travel the length of the CTS 70 without interfering with any object.

COVANA LIMITED WARRANTY

The Limited Warranty starts twelve (12) months after the initial invoiced dealer purchase date from COVANA. If the unit is sold to a consumer within the first year, the Limited Warranty starts on the original consumer purchase date.

The limited warranty on COVANA Unit sold outside Canada and the United States will take effect sixty (60) days after the date shown on Covana/Canimex commercial invoice to the distributor or the COVANA authorized dealer.

The Limited Warranty is applicable only upon proof of purchase and solely to the original COVANA Unit owner bought from a COVANA authorized dealer and installed for residential use.

To obtain service, contact your COVANA authorized dealer as soon as possible, and use all reasonable means to protect the COVANA Unit from further damage. Upon proof of purchase, your COVANA authorized dealer will correct the defect subject to the terms and conditions contained in this limited warranty. The COVANA Unit owner is responsible for providing access to the COVANA Unit to perform the repair.

WARRANTY COVERAGE

SHELL & FIBER PANELS: 5 YEARS

COVANA warrants the Legend – Legend X – C-EP – Evolution fiber panels and the Oasis inner shell and outer shell against fracture, abnormal deformation or leaking for five (5) years from the original purchase date.

- **Labor** associated to replacement parts or repairs under this warranty is paid for three (3) years from the original purchase date.
- **Freight charges** related to replacement of parts under this warranty are paid for three (3) years from the original purchase date.

Discoloration and surface abrasions due to weathering will occur naturally over time and are not considered defects. Improper spa water chemistry and misuse of spa chemicals may cause discoloration of the inner shell. Inner shell discoloration is not considered a defect and is not covered under this warranty. Cover melting caused by convergent or indirect sunlight reflection or overheating from an insulating protection is not covered under this warranty. Falling debris causing damage to the COVANA Unit is not covered by this warranty. Condensation may occur due to hot tub water temperature and other outside environmental factors; this is deemed to be a natural phenomenon and it is not covered under this Limited Warranty.

STRUCTURE: 3 YEARS

COVANA warrants the aluminum frame, brackets and telescoping sleeves against breakage and fracture due to defects in materials and workmanship for three (3) years from the original purchase date.

- **Labor** associated to replacement of parts or repairs under this warranty is paid for one (1) year from the original purchase date.
- **Freight charges** related to replacement parts under this warranty are paid for ninety (90) days from the original purchase date.

Installation on any surface other than the one recommended in this manual, or any damage caused by this inappropriate installation or any damage caused by operation under conditions exceeding rated capacities (such as snow, artificial grass, furniture, creating overweight) is not covered under this warranty.

POWDER COAT: 3 YEARS

COVANA warrants the powder paint on all surfaces against chipping and peeling under normal conditions for three (3) years from the original purchase date.

- **Labor** associated to replacement of parts or repairs under this warranty is paid for one (1) year from the original purchase date.
- **Freight charges** related to replacement parts under this warranty are paid for ninety (90) days from the original purchase date.

Discoloration and surface abrasions due to weathering will occur naturally over time and are not considered defects. Chipping of powder paint on fastening hardware may occur during assembly and servicing of the COVANA Unit and are not covered by the warranty.

MECHANICAL COMPONENTS: 3 YEARS

COVANA warrants the mechanical components such as: the motor, gear boxes, chains, drive shafts and jacks, for three (3) years from the original purchase date.

- **Labor** associated to replacement of parts or repairs under this warranty is paid for one (1) year from the original purchase date.
- **Freight charges** related to replacement parts under this warranty are paid for ninety (90) days from the original purchase date.

Mechanical components damaged by mineral contaminants, such as rocks, dust or sand, undrained underground installations, undrained surface, flooding area or permanent water accumulation is not covered under the warranty.

LED LIGHT ASSEMBLY & ELECTRICAL COMPONENTS: 1 YEAR

COVANA warrants the LED light system and solar panel against manufacturing defect against malfunction for one (1) year from the original purchase date.

COVANA warrants the electrical components such as cables and wires, key switch assembly and limit switches against malfunction for one (1) year from the original purchase date.

- **Labor** associated to replacement of parts or repairs under this warranty is paid for one (1) year from the original purchase date.
- **Freight charges** related to replacement parts under this warranty is paid for ninety (90) days from the original purchase date.

Electrical damage caused by a non-permanent installation of the key switch 5 ft (1.5 m) away from the spa and 5 ft (1.5 m) above the ground as indicated in the installation manual could void the limited warranty.

COMPONENTS, PARTS AND ACCESSORIES: 90 DAYS

COVANA warrants components and accessories subject to normal wear such as: batteries, seals, roller shades, screens, key switch barrels cover, to be free of manufacturing defects for ninety (90) days from the original purchase date.

- **Labor** associated to replacement of parts or repairs under this warranty is paid ninety (90) days from the original purchase date.

- **Freight charges** related to replacement parts under this warranty are paid ninety (90) days from the original purchase date.

LIMITATIONS

COVANA offers replacement parts until the durations prescribed in the Warranty coverage end OR ninety (90) days from the replacement date.

Covana may void the warranty if:

- We determine that the COVANA Unit has been subjected to alteration, neglect, misuse, abuse or lack of maintenance or adjustment or installation of equipment which is not in accordance with guidelines within this manual.
- The electrical installation was not performed by a licensed electrical contractor or does not comply with all applicable local electrical codes and regulations.
- Any accessory, upgrade or modification implemented to the COVANA Unit are not original from COVANA.
- The installation or repairs were performed by other than a COVANA authorized dealer.
- The owner dismantles the COVANA Unit.
- The COVANA authorized dealer and/or the COVANA Unit owner did not consider and respect the relevance of all criteria, risks and liability stipulated in this manual prior to the installation of the COVANA Unit.

COVANA may void this limited warranty and cannot be held responsible for any damage after a repair or maintenance performed on a COVANA Unit even by a COVANA authorized dealer, which goes against this manual. COVANA is not liable for any injury, loss or damage, direct or consequential, arising out of the inability to use the COVANA Unit.

EXCLUSIONS

- COVANA excludes from this limited warranty a COVANA Unit installed in a commercial application.
- COVANA is not deemed responsible for failures or damages caused by installation in a humid area, flood zone, corrosive environment or acts of God or other causes beyond the control of COVANA.
- COVANA's warranty does not cover mileage allocation or travel expenses associated with any repair or replacement part.
- COVANA is not deemed responsible for any damage or malfunction caused by the relocation of the COVANA Unit not performed by a COVANA authorized dealer to another address.
- COVANA or the COVANA authorized dealer is not deemed responsible for any equipment, furniture or landscaping aside from the COVANA Unit.

DISCLAIMER AND LEGAL RIGHTS

This Limited Warranty overrules all other warranties, either expressed or implied. No other party than COVANA is authorized to alter this limited warranty in any way. This limited warranty gives you specific legal rights. You may also have other rights that vary depending on the country, state or province. COVANA//Canimex Inc.'s liability under this limited warranty, if any, will not exceed the original amount paid for the defective COVANA Unit. The limited warranty is exclusive and in lieu of all other warranties of quality, whether written, oral or implied.



Contact your local authorized Covana dealer for all service-related issues.

Made in Canada by Covana,
a division of the Canimex group

COVANA.COM

CANIMEX GROUP

PATENTED

CANADA 2,532,429

US 11/162,557

UK 0515168.3

AUSTRALIA 2006200251

The information in this manual was accurate at the time of print. The manufacturer reserves the right to change or improve its product without prior notice.